

OWNER/ OPERATOR MANUAL

Maintenance Kits

MODELS: 4M04T, 4M010T

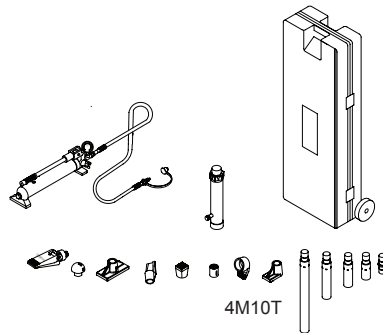
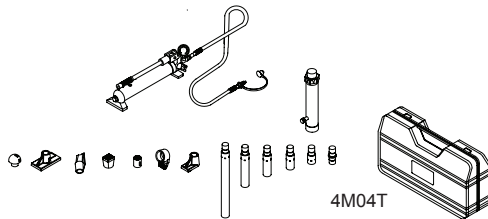

⚠ **WARNING:** Cancer and Reproductive Harm.
⚠ **AVERTISSEMENT:** Cancer et dommages au système reproducteur.
⚠ **ADVERTENCIA:** Cáncer y daño reproductivo.
www.P65Warnings.ca.gov

SAFETY and GENERAL INFORMATION

Save these instructions. For your safety, read and understand the information contained within. The owner and operator shall have an understanding of this product and safe operating procedures before attempting to use this product. Instructions and Safety information shall be conveyed in the operators native language before use of this product is authorized. Make certain that the operator thoroughly understands the inherent dangers associated with the use and misuse of the product. If any doubt exists as to the safe and proper use of this product as outlined in this factory authorized manual, remove from service.

Inspect before each use. Do not use if broken, bent, cracked or otherwise damaged parts are noted. If any component of this product has been or suspected to have been subjected to a shock load (a load dropped suddenly, unexpectedly upon it), discontinue use until checked out by an Williams authorized service center. Owners and operators of this equipment shall be aware that the use and subsequent repair of this equipment may require special training and knowledge. It is recommended that an annual inspection be done by qualified personnel and that any missing or damaged parts, decals, warning/safety labels or signs be replaced with factory authorized replacement parts only. Any component of this Williams Kit that appears to be damaged in any way, is worn or operates abnormally shall be removed from service immediately until such time as it can be repaired/replaced. Labels and Operator's Manuals are available from manufacturer.

PRODUCT DESCRIPTION

Williams Kits are designed to be used for pushing, spreading, and pressing of vehicle body panels as well as various component parts and assemblies. A variety of attachments are included. 4M04T is rated at 8,000 PSI; 4M10T is rated at 10,000 PSI. Rams are rated from 4 to 10 tons respectively.



WARNING: To reduce the risk of personal injury and/or property damage, ensure that the rated working pressure of each pressurized attachment be equal to or greater than the rated working pressure developed by the hydraulic pump.



Always check connections before using. Alteration of these products is strictly prohibited. Use only those adapters and attachments provided and approved by the manufacturer.

Note: when extension tubes and/or offset attachments are used, the rated capacity is always reduced by 50% for each tube or offset attachment connected. See Parts Section for identification of "offset" attachments.

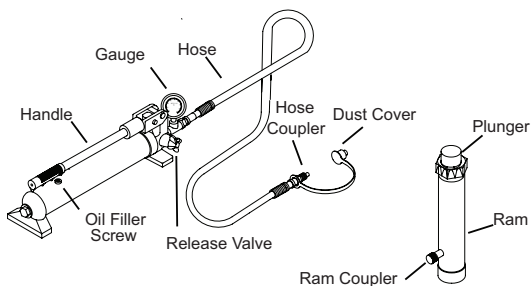

Figure 1 - Pump and Ram Components

SPECIFICATIONS

Model	Pump Capacity (psi)	Ram Capacity (ton)	Ram			Number of Attachments	Weight (lb)
			Closed Height (in)	Extended Height (in)	Effective area (in ²)		
4M04T	8,000	4	11	15 3/4	0.998	14	46
4M10T	10,000	10	13 5/8	19 3/4	2.411	13	84

⚠ WARNING



Failure to comply with the following warnings may result in **personal injury** as well as **property damage**.



- Study, understand, and follow all instructions provided with and on this device before use.
- The user must be a qualified operator familiar with the correct operation, maintenance, and use of rams.



Wear protective gear when operating hydraulic equipment.



This device is **NOT** suitable for use as **support** device! As the load is lifted, use blocking and cribbing to guard against a falling load. Stay clear of a lifted load before it is properly supported. Never rely on hydraulic pressure to support a load.



Crush Hazard. Keep hands and feet away from ram and workpiece during operation.



- Do not exceed rated capacity of the ram or any equipment in the system. The ram is designed for a max. pressure of 10,000 psi.
- Do not connect a ram to a pump with higher pressure rating.

- Do not subject ram to a shock loads, a load dropped suddenly, causing the system pressure to exceed rated pressure.



The system operating pressure must not exceed the pressure rating of the lowest rated component the system. Install a pressure gauge or other load measuring instrument to monitor the operating pressure. Burst hazard exists if hose, connection or any other component in the system exceed its rated pressure.



Avoid damaging hydraulic hose. Do not allow hose to kink, twist, curl, crush, cut or bend so tightly that fluid flow within the hose is blocked or reduced. Periodically inspect the hose for wear.



Do not pull, position or move ram setup by the hose. Use carrying handle or other means of safe transport.



Do not handle pressurized hoses. Never attempt to grasp a leaking pressurized hose. Ensure to release the system pressure before disconnecting hydraulic hose or connections.



Hydraulic fluid can ignite and burn. Keep hydraulic equipment away from flames and heat. Excessive heat will soften seals, resulting in fluid leaks. Heat also weakens hose materials.



Ram must be on a stable base which is able to support the load while pushing or lifting. Use shims, friction material or constrains to prevent slippage of the base or load. Ensure ram is fully engaged into/onto adapters, extension accessories.



Center load on ram. Distribute load evenly across the entire saddle surface. Do not off-center loads on a ram. The load can tip or the ram can "kick out".



Never try to disassemble a hydraulic ram, refer repairs to qualified, authorized personal. Contact Williams tech service for authorized service center.



Do not subject hose to sharp objects or heavy impact.



Hose material or seals must not come in contact with corrosive materials such as battery acid, creosote-impregnated objects and wet paint. Never paint a coupler or hose.



- No alteration shall be made to the ram.
- Use only factory authorized fasteners, accessories and hydraulic fluid.

BEFORE USE

1. Before using this product, read the owner's manual completely and familiarize yourself thoroughly with the product, its components and recognize the hazards associated with its use.
2. Inspect before each use. Do not use if bent, broken, leaking or damaged components are noted.
3. Check to ensure that all parts of your kit are included (see illustration and parts list).
4. Carefully remove the dust caps and plugs from hose coupler and ram coupler.
5. Connect hose coupler to ram coupler, ensure that there are no fluid leaks.
6. Locate and open release valve. Close release valve clockwise and pump handle until ram is fully extended, then open release valve counter-clockwise until ram has fully retracted.
7. With ram fully retracted and release valve open, place pump in horizontal position. Open oil filler screw (on reservoir body, near the back). This will release air trapped within the reservoir. Re-tighten the oil filler screw.
8. If using with air actuated units, an air source of at least 7.8 CFM @ 110 psi is required.

GENERAL SAFETY INFORMATION

1. Ensure that attachments are fully engaged before applying load.
2. Ensure that load is centrally applied to attachment or ram saddle. Do not load off center.
3. Always monitor the force applied to workpiece by using a load cell and indicator or you may monitor pressure developed in the ram by using an inline pressure gauge, then calculate the applied force using the formula:
 $F = P \times A$, where $F = \text{lb force}$, $P = \text{pressure in psi}$, and $A = \text{effective ram area in in}^2$.
Ram Area of Model 4M04T is: 0.998 in²
Ram Area of Model 4M10T is: 2.411 in²
Refer to Load-Pressure correlation chart on page 11. If bowing or bending of ram or any attachment occurs during use, "**STOP**", release pressure immediately and reconsider application. Application may not be compatible with product, a ram kit with a higher capacity may be needed.

OPERATION

! ALWAYS monitor pressure, load or position using suitable equipment. Pressure may be monitored by means of an optional manifold and gauge. Load may be monitored by means of a load cell and digital indicator.

Note: Any attachment that is not loaded centrally, as through the centerline of the ram, is considered to be "offset". When extension tubes and/or offset attachments are used, the rated capacity is always reduced by 50% for each tube or offset attachment connected.

1. Pump may be used in horizontal and vertical position as illustrated on figure 2 below.

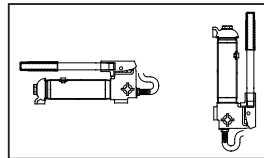

Figure 2 - Horizontal and Vertical position

2. Locate and close release valve by turning it clockwise until firmly closed. (Do not over tighten)
3. Operate by pumping handle. This will send fluid from the pump reservoir into the high pressure hose assembly and into the ram assembly.
4. Continue pumping until ram reaches desired position.

! NEVER operate pump with release valve closed and disconnected from application. If operated in this condition, the hose and connections become pressurized. This increases burst hazard. Damage may occur to pump and its components.

5. To Release Pressure on work piece: Slowly, carefully turn the release valve counter-clockwise until ram retracts to desired position. Never turn release valve more than 1/2 full turn. The ram return system is spring loaded and the release valve system is metered, allowing controlled retraction of the ram.

Basic Setup

The capacity of the body repair kit can be significantly affected by the number of attachments used and the type of load applied. The approximate load capacity of each function setup is illustrated below. When two or more extension tubes are used together, be sure to position the shortest tube further away from the ram.

Note: Not all accessories in the illustrations provided in the Williams Kits.

A. Push & Stretch

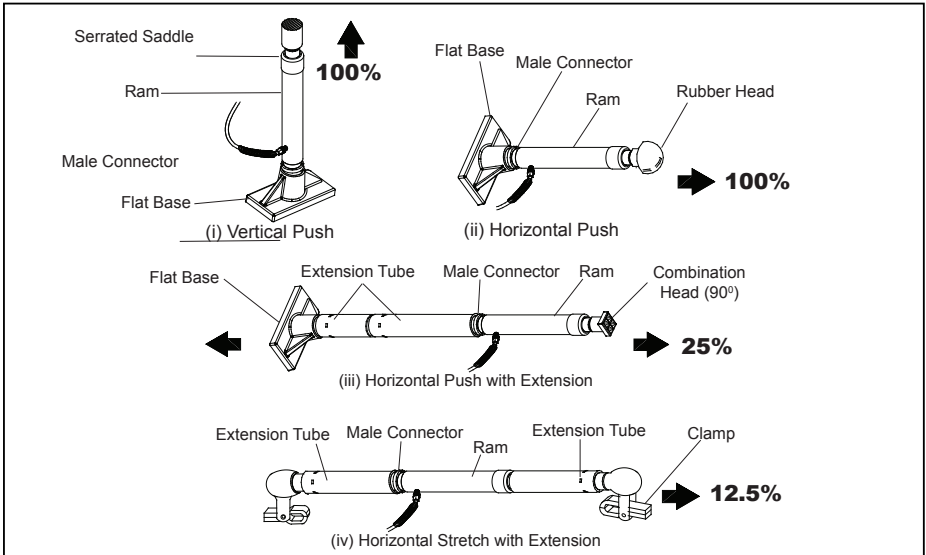

B. Clamp & Pull

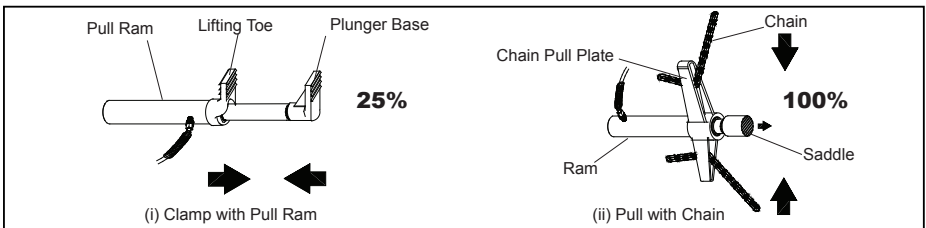

C. Spread

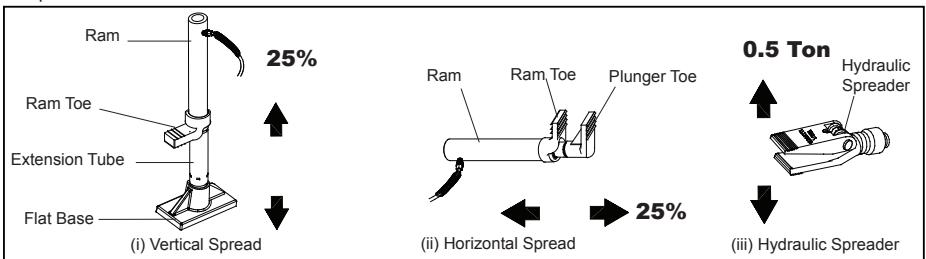

MAINTENANCE

1. Inspect hoses and connections daily. Replace damaged components immediately with Williams Replacement Parts only.
2. Tighten connections as needed. Use pipe thread sealing compound when servicing connections.
3. Use only a good grade hydraulic oil. Avoid mixing different types of fluid and Never use brake fluid, turbine oil, transmission fluid, motor oil or glycerin. Improper fluid can cause premature failure of the ram and the potential for sudden and immediate loss of load. We recommend Hein-Werner 8H1G or equivalent.

Adding oil

1. With ram fully lowered, set pump unit in its normal, level position. Locate and remove oil filler screw.
2. Fill until oil is within 3/8" of the oil filler screw hole opening, re-install oil filler screw.

Changing oil

For best performance and increased system life, replace the complete fluid supply at least once per year.

1. With ram fully lowered, remove the oil filler screw from the pump reservoir as above.
2. Lay the pump on its side and drain the fluid into a suitable container.

Note: Dispose of hydraulic fluid in accordance with local regulations.

3. Set pump in its level upright position.
4. Fill with good quality jack oil to within 3/8" of the oil filler screw hole opening. Reinstall oil filler screw.

Lubrication

A coating of light lubricating oil to pivot points and hinges will help to prevent rust and assure that pump assemblies move freely.

Cleaning

Periodically check the pump piston and ram for signs of rust or corrosion. Clean as needed and wipe with an oily cloth.

Note: Never use sandpaper or abrasive material on these surfaces!

Storage

When not in use, store with the pump piston and ram fully retracted.

How to remove faulty coupler:

If ram does not retract,:

1. Secure load by other means.
2. Depressurize pump and hose
3. Remove the ram from application.
4. Disconnect and replace with new coupler.

Important: Do not attempt to grasp ram with pliers or wrench without first wrapping the jaws of such tool with rags or similar padding.

How to bleed air from system:

1. Place pump at a higher elevation than the hose and ram as shown in figure 3 below.
2. Operate pump to fully extend and retract the ram 2 or 3 times. The objective is to force the air bubbles up hill and back to the pump reservoir.
3. To bleed the air from pump reservoir, simply open the oil filler screw. Re-install after bleeding.

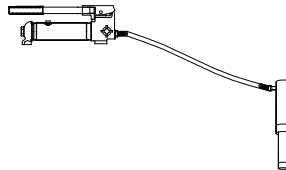

Figure 3 - Illustration to bleed air from system

TROUBLESHOOTING GUIDE

The following information is intended as an aid in determining if problem exists. Pump and ram should be repaired only by authorized Williams Service Center. For repair service, contact service center in your area.

Symptom	Possible Causes	Corrective Action
Erratic action	<ul style="list-style-type: none"> • Air in system or pump cavitation. • External leakage in ram. • Ram sticking or binding. 	<ul style="list-style-type: none"> • Vent the system (refer to figure 3). • Contact service center. • Contact service center.
Ram will not extend, or respond to pressurized fluid	<ul style="list-style-type: none"> • Overload condition. • Loose/Faulty couplers. • Oil level in pump is low. 	<ul style="list-style-type: none"> • Remedy overload condition. • Tighten/Replace couplers. • Fill and bleed the system.
Ram extend only partially	<ul style="list-style-type: none"> • Oil level in pump is low. • Overload condition. • Ram is sticking or binding. • Pump malfunction. 	<ul style="list-style-type: none"> • Fill and bleed the system. • Remedy overload condition. • Contact service center. • Contact service center.
Ram move slower than normal	<ul style="list-style-type: none"> • Loose connection or coupler. • Restricted hydraulic line or fitting. • Pump not working correctly. • Ram seals leaking. 	<ul style="list-style-type: none"> • Tighten connection or coupler. • Clean and replace if damaged. • Check pump's operating instructions. • Contact service center.
Ram responds to pressurized fluid, but system does not maintain pressure	<ul style="list-style-type: none"> • Overload condition. • Pump malfunctioning. • Ram seals leaking. 	<ul style="list-style-type: none"> • Remedy overload condition. • Contact service center. • Contact service center.
Oil leaking from ram	<ul style="list-style-type: none"> • Worn or damaged seals. 	<ul style="list-style-type: none"> • Contact service center.
Ram will not retract or retracts slower than normal	<ul style="list-style-type: none"> • Malfunctioning coupler, damaged application. • Pump reservoir overfilled. • Ram damage internally. 	<ul style="list-style-type: none"> • Secure load by other means. Depressurize pump and hoses, remove application and replace coupler. • Secure load by other means. Depressurize pump and hoses, remove application, then drain fluid to proper level. • Contact service center.
Poor performance	<ul style="list-style-type: none"> • Oil level in pump is low. • Air trapped in system. 	<ul style="list-style-type: none"> • Ensure proper oil level. • Vent the system (refer to figure 3).

Maintenance Kits

Note: Not all components are replacement items, but are illustrated as a convenient reference of location and position in the assembly sequence. To ensure safe and reliable performance, replace worn or damaged parts with Williams authorized repair parts only.

MODEL: 4M04T

Item	Part No.	Description	Qty
1	J0401	Hand Pump Assembly	1
2	J0402	4 Ton Ram Assembly	1
3	J0403	Oil Hose Assembly (w/ coupler)	1
4	J0404	Blow Mold Case	1
5	J0405	Hydraulic Spreader, (1000 Lbs capacity)	1
6	J0406	Combination Head (90 Deg.)	1
7	J0407	Rubber Head	1
8	J0408	Ram Toe (offset)	1
9	J0409	Plunger Toe (offset)	1
10	J0410	Flat Base	1
11	J0411	Serrated Toe	1
12	J0412	Wedge Head (offset)	1
13	J0413	Male Connector	1

Item	Part No.	Description	Qty
14	J0414	Extension Tube (3")	1
15	J0415	Extension Tube (6-1/8")	1
16	J0416	Extension Tube (8-1/2")	1
17	J0417	Extension Tube (16-1/2")	1
18	J0418	Extension Tube (19-1/2")	1
19	CRZ14M	Hose Coupler - Male, 1/4" -18 NPTF	1
20	CRZ14F	Hose Coupler - Female, 1/4" -18 NPTF	1
21	F040-20012-000	Dust Cover - Hose	1
22	F040-90009-K03	Pump Handle	1
23	F040-90107-K02	Oil Filler Screw	1
24	F100-80001-000	Pressure Gauge	1
25	F040-21000-000	Release Valve Knob	1
-	F0400S-85	Repair Kits	1

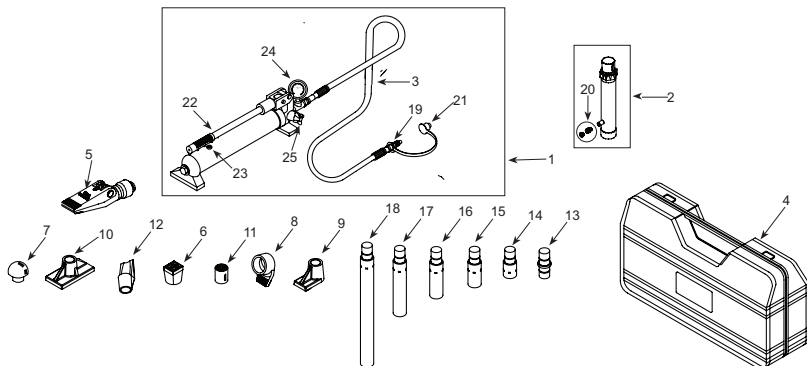

Figure 4 - Replacement Parts Illustration for Model 4M04T

Maintenance Kits

Note: Not all components are replacement items, but are illustrated as a convenient reference of location and position in the assembly sequence. To ensure safe and reliable performance, replace worn or damaged parts with Williams authorized repair parts only.

MODEL: 4M10T

Item	Part No.	Description	Qty
1	J1001	Hand Pump Assembly	1
2	J1002	4 Ton Ram Assembly	1
3	J0403	Oil Hose Assembly (w/ coupler)	1
4	J1004	Blow Mold Case	1
5	J1005	Hydraulic Spreader, (1000 Lbs Capacity)	1
6	J1006	Combination Head (90 Deg.)	1
7	J1007	Rubber Head	1
8	J1008	Ram Toe (offset)	1
9	J1009	Plunger Toe (offset)	1
10	J1010	Flat Base	1 </td
11	J1011	Serrated Toe	1
12	J1012	Wedge Head (offset)	1
13	J1013	Male Connector	1

Item	Part No.	Description	Qty
14	J1014	Extension Tube (4")	1
15	J1015	Extension Tube (10")	1
16	J1016	Extension Tube (18")	1
17	J1017	Extension Tube (27")	1
18	J1018	Oil Filler Screw	1
19	CRZ14M	Hose Coupler - Male, 1/4" -18 NPTF	1
20	CRZ14F	Hose Coupler - Female, 1/4" -18 NPTF	1
21	F040-20012-000	Dust Cover - Hose	1
22	F100-90009-K01	Pump Handle	1
23	F100-80001-000	Pressure Gauge	1
24	F040-21000-000	Release Valve Knob	1
-	F1000S-85	Repair Kits	1

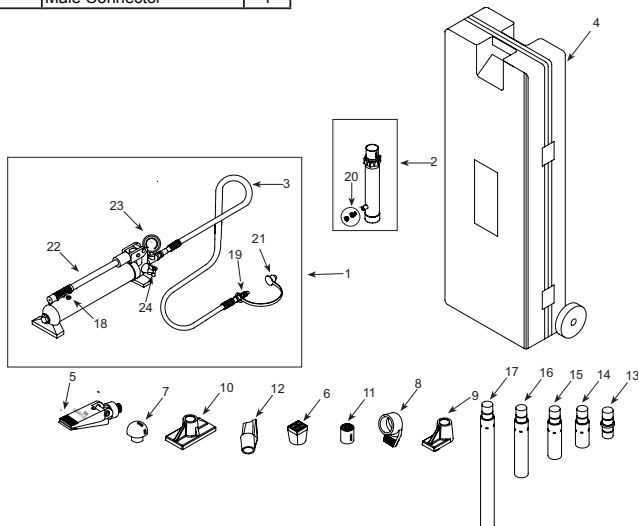

Figure 5 - Replacement Parts Illustration for Model 4M10T

LIMITED LIFETIME WARRANTY

J.H. Williams Tool Group warrants this product to be free from defects in material and workmanship for the life of the product as long as the original purchaser owns the product. The warranty is non-transferable and is subject to the terms, exclusions, and limitations described below:

- Damaged components, including but not limited to bent rams, dented or crushed cylinder walls, broken welds or couplers as well as worn out seals, o-rings and springs are the result of misuse and not covered by warranty and Williams will not provide any warranty credit for such damaged components.
- This warranty does not cover ordinary wear and tear, overloading, alterations (including repairs or attempted repairs not performed by Williams or one of its authorized personnel), improper fluid use, or use of the product in any manner for which the product was not intended or the use of which is not in accordance with the instructions or warnings provided with the product.
- In the unlikely event that a Williams product fails due to material defect in workmanship, you may contact J.H. Williams Tool Group for disposition. In such cases, the customer's sole and exclusive remedy for any breach or alleged breach of warranty is limited to the repair or replacement of the defective product.
- Under no circumstances is Williams liable for any consequential or incidental damage or loss whatsoever.
- THIS WARRANTY IS LIMITED TO NEW PRODUCTS SOLD THROUGH AUTHORIZED DISTRIBUTORS AND OTHER CHANNELS DESIGNATED BY WILLIAMS. NO AGENT, EMPLOYEE OR OTHER REPRESENTATIVE OF WILLIAMS IS AUTHORIZED TO MODIFY THIS WARRANTY.
- THE FOREGOING IS EXCLUSIVE AND IS IN LIEU OF ALL OTHER EXPRESS AND IMPLIED WARRANTIES, INCLUDING BUT NOT LIMITED TO THE IMPLIED WARRANTIES OF MERCHANTABILITY AND FOR A FITNESS FOR A PARTICULAR PURPOSE.
- Components not manufactured by Williams including certain motor systems, gasoline engines, and other are not covered by this warranty and instead are covered by the manufacturer's separate manufacturer's warranty provided in the package.
- Williams' liability in all cases is limited to, and will not exceed the purchase price paid for the product.

J.H. Williams Tool Group
6969 Jamesson Road,
Midland, GA 31820

Load - Pressure Correlation For Model 4M04T & 4M10T

Always monitor the force applied to workpiece by using a load cell and indicator or you may monitor pressure developed in the ram by using an inline pressure gauge, then calculate the applied force using the formula:

$F = P \times A$

where F = Force/ Load (lb);
 P = Hydraulic working pressure (psi) and;
 A = Ram effective area (in²)

For model 4M04T, A = 0.998 in² ;
 For model B55115, A = 2.411 in²

Example1

Model 4M04T lifting 5,000 lb will require what pressure?

Pressure = 5,000 lb / 0.998 in² = 5,010 psi

Example2

Model 4M10T operating at 6,000 psi will generate what force?

Force = 6,000 psi x 2.411 in² = 14,466 lb

Load (lb)	Pressure of 4 Ton Ram, where A = 0.998 in ² (psi)	Pressure of 10 Ton Ram, where A = 2.411 in ² (psi)
1,000	1,002	415
2,000	2,004	830
3,000	3,006	1,244
4,000	4,008	1,659
5,000	5,010	2,074
6,000	6,012	2,489
7,000	7,014	2,903
8,000	8,016	3,318
9,000	\	3,733
10,000		4,148
11,000		4,562
12,000		4,977
13,000		5,392
14,000		5,807
15,000		6,221
16,000		6,636
17,000		7,051
18,000		7,466
19,000		7,881
20,000		8,295

Load - Combination Correlation For Model 4M04T & 4M10T

Always consider the number of attachments that you are using and follow the combination load suggestions in the Basic Setup section on page 5. Follow the below table for correlation between percentage, load and pressure.

Percentage %	4M04T		4M10T	
	Load (lb)	Pressure (psi)	Load (lb)	Pressure (psi)
100%	8,000	8,016	20,000	8,295
50%	4,000	4,008	10,000	4,148
25%	2,000	2,004	5,000	2,074
12.5%	1,000	1,002	2,500	1,037