

WALKER

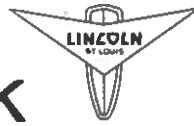

Model 93666

AIR / MANUAL SERVICE JACK

2 TON CAPACITY

SERIES "A", "B" & "C"



LINCOLN ST. LOUIS
4010 GOODFELLOW BLVD. • ST. LOUIS, MO. 63120 • (314) 383-5900

A DIVISION OF
McNEIL
CORPORATION

SECTION - **W1**
PAGE - **6C**

HYDRAULIC UNIT ASSEMBLY

①

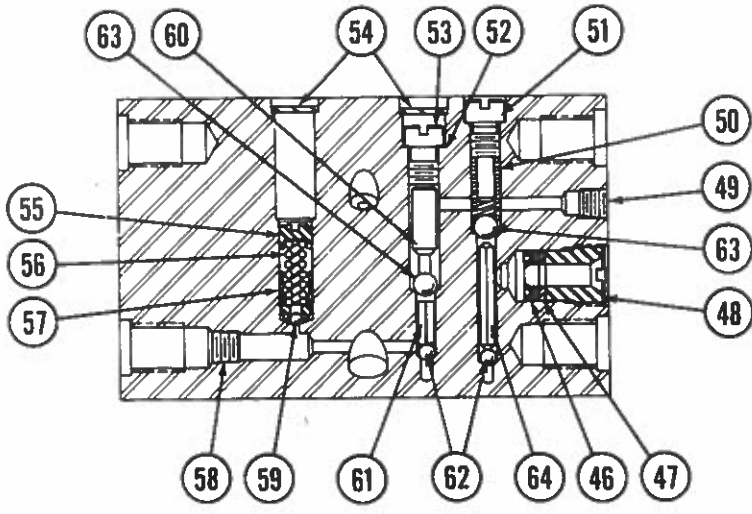
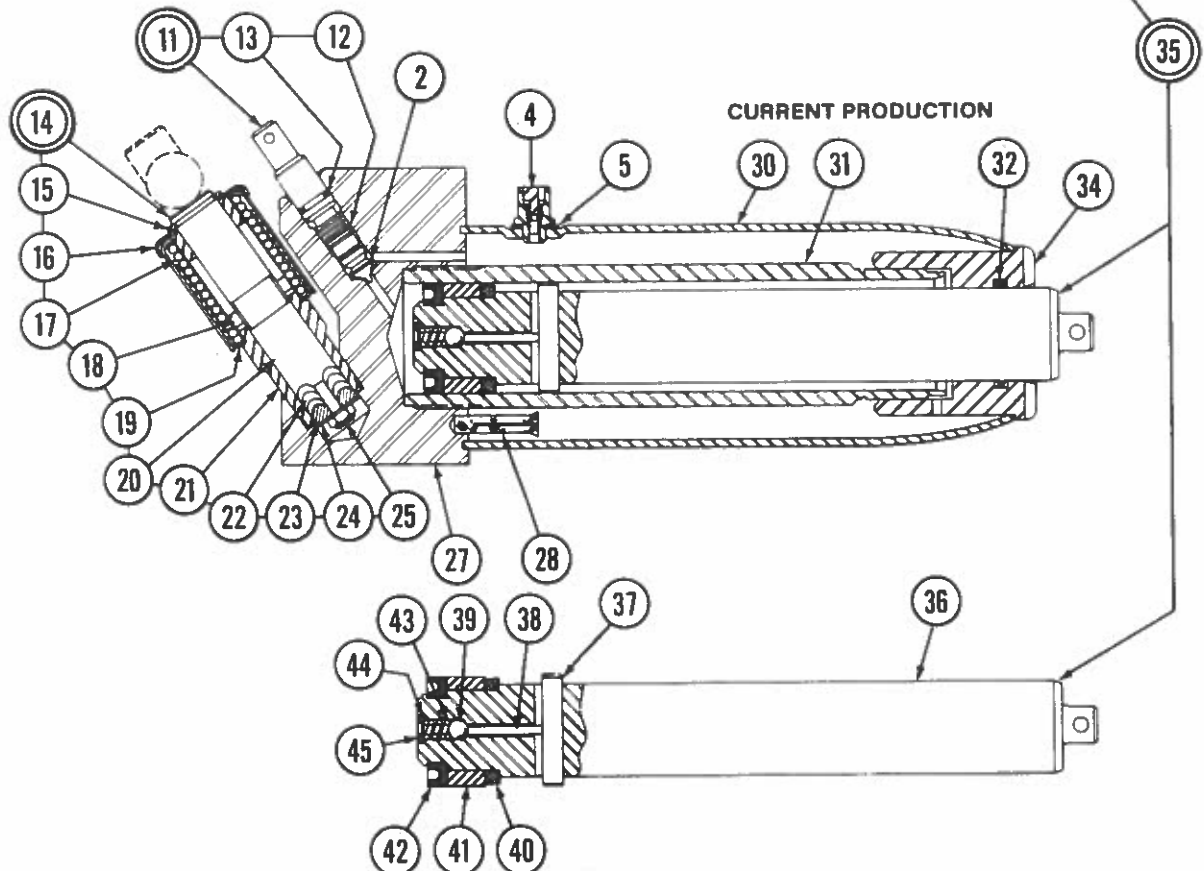
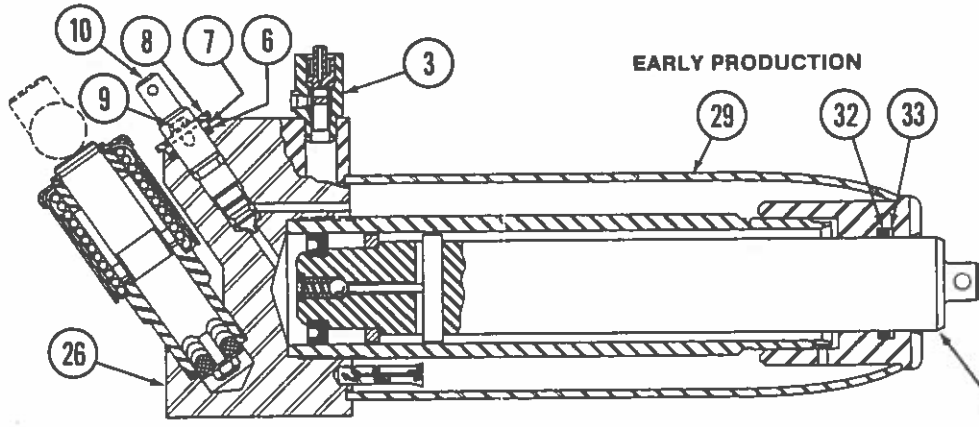

SERVICE PARTS

Code No.	Part Number	Description	Series	No. Req'd	Code No.	Part Number	Description	Series	No. Req'd
1	(See Note 1)	Hydraulic Unit Assy	—	1	36	230302	Ram	A,B & C	1
2	218043	Release Valve	A,B & C	1	37	226328	Cross Pin	A,B & C	1
3	227095	Filler/Vent Plug	A	1	38	230824	Up-Stop Pin	A,B & C	1
4	231316	Filler/Vent Plug	B & C	1	39	203199	Ball	A,B & C	1
5	200003	Filler Plug Gasket	B & C	1	40	230300	Back-Up Washer	A,B & C	1
6	212375	"O" Ring	A & B	1	41	230301	Heel Plate	A,B & C	1
7	212374	Back-Up Washer	A & B	1	42	228256	"U" Cup	A,B & C	1
8	218414	Retaining Plate	A & B	1	43	226331	Spring	A,B & C	1
9	222940	Screw	A & B	2	44	223166	Screen	A,B & C	1
10	218413	Release Stem	A & B	1	45	210411	Washer	A,B & C	1
11	233376	Release Stem Assy	C	1	46	230004	"U" Cup	A,B & C	1
12	224869	Release Stem	C	1	47	230003	Back-Up Washer	A,B & C	1
13	216143	"O" Ring	C	1	48	223213	Gland Nut	A,B & C	1
14	227045	Pump Assembly	A,B & C	1	49	210311	Plug	A,B & C	1
15	201803	Retainer	A,B & C	1	50	222201	Spring	A,B & C	1
16	226365	Cover	A,B & C	1	51	226324	Pressure Plug	A,B & C	1
17	226348	Spring	A,B & C	1	52	204842	Gasket	A,B & C	1
18	201142	Cross Pin	A,B & C	1	53	211013	Pressure Plug	A,B & C	1
19	226357	Bottom Sleeve	A,B & C	1	54	201733*	Expansion Plug	A,B & C	2
20	226350	Piston	A,B & C	1	55	226373*	Adj. Nut	A,B & C	1
21	226339	Cylinder	A,B & C	1	56	226375*	Spring	A,B & C	1
22	201828	"V" Packing	A,B & C	3	57	226376*	Adapter	A,B & C	1
23	226351	Adapter	A,B & C	1	58	210311	Plug	A,B & C	1
24	204233	Washer	A,B & C	1	59	203196*	Valve	A,B & C	1
25	224275	Nut	A,B & C	1	60	211014	Spacer	A,B & C	1
26	(See Note 2)	Unit Block	A & B	1	61	226330	Spacer	A,B & C	1
27	233137	Unit Block	C	1	62	203198	Valve	A,B & C	2
28	221318	Screen	A,B & C	2	63	203201	Valve	A,B & C	2
29	(See Note 3)	Oil Tank	A	1	64	230295	Spacer	A,B & C	1
30	231675	Oil Tank	B & C	1					
31	230823	Cylinder	A,B & C	1					
32	221748	Quad Ring	A,B & C	1					
33	221747	Back-Up Washer	(Note 4)	1					
34	225516	Tank Nut	A,B & C	1					
35	230299	Ram Assembly	A,B & C	1					

Note 1 — Contact factory or nearest authorized service depot when complete unit assembly is needed.

Note 2 — When unit block replacement is required use P/N 233137 — Add one each P/N 231675 oil tank, P/N 231316 filler/vent, P/N 20003 gasket and P/N 233376 release stem assembly as old parts will not interchange.

Note 3 — Use P/N 231675 oil tank plus one each P/N 212540 filler screw and P/N 20003 gasket.

Note 4 — Eliminate from late production. Groove in P/N 225516 tank nut narrowed.

* — Repairs not recommended without required special tools and test equipment.

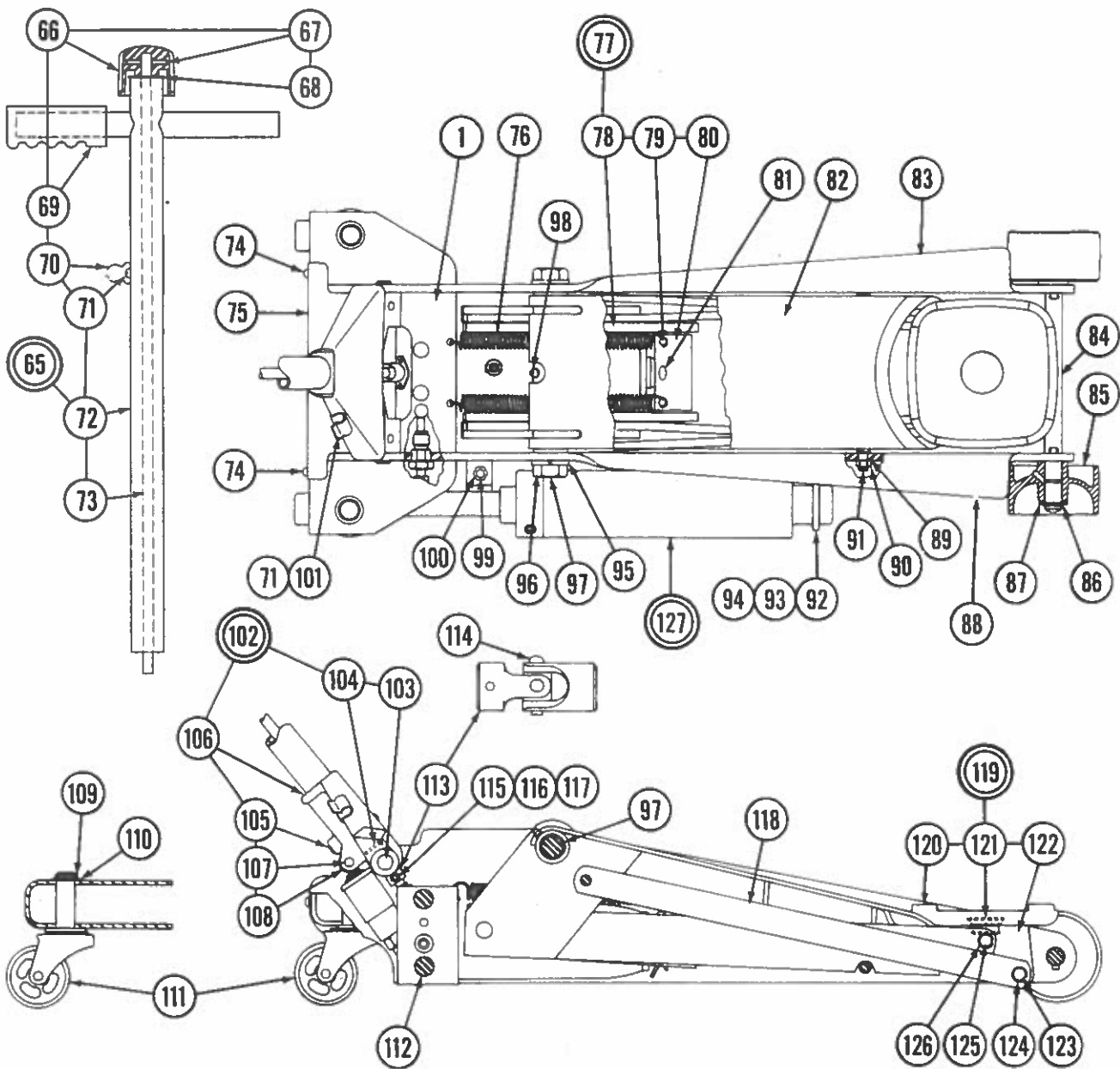

(127) AIR-HYDRAULIC PUMP ASSEMBLY

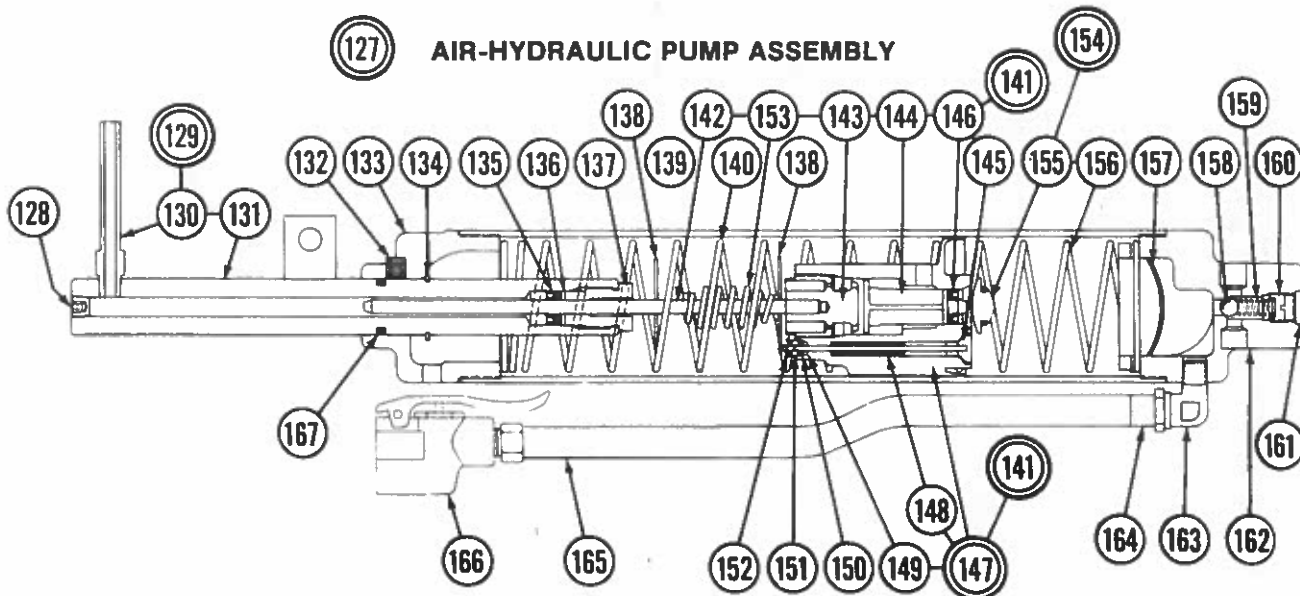

SERVICE PARTS

Code No.	Part No.	Description	Series	No. Req'd	Code No.	Part No.	Description	Series	No. Req'd
65	231582	Handle Assembly	A, B & C	1	120	221702	Cap	A, B & C	1
66	221937	Release Knob	A, B & C	1	121	226355	Stud	A, B & C	1
67	221938	Roll Pin	A, B & C	1	122	226491	Cap Housing	A, B & C	1
68	230328	Washer	A, B & C	1	123	226349	Pin	A, B & C	1
69	221809	Handle Grip	A, B & C	2	124	201801	Retaining Ring	A, B & C	2
70	223172	Hose Clip	A, B & C	1	125	221703	Pin	A, B & C	1
71	224081	Screw	A, B & C	2	126	201801	Retaining Ring	A, B & C	2
72	230327	Handle Tube & Cross Bar	A, B & C	1	127		Air/Hydraulic Pump Assembly	A, B & C	1
73	230325	Turning Rod	A, B & C	1			Pipe Plug	A, B & C	1
74	221724	Drive Screw	A, B & C	2	128	210311			
75	221723	Shroud	A, B & C	1	129	230291	Pump Cylinder Assembly	A, B & C	1
76	230312	Spring	A, B & C	2	130	229754	Extension Tube	A, B & C	1
77	230309	Cross Head & Link Assy.	A, B & C	1	131	231581	Pump Cylinder Assembly	A, B & C	1
78	230314	Pull Link	A, B & C	2	132	226451	Set Screw	A, B & C	2
79	226335	Stud	A, B & C	2	133	226450	End Block	A, B & C	1
80	230311	Cross Head	A, B & C	1	134	221820	Retaining Ring	A, B & C	1
81	230399	Cotter Pin	A, B & C	1	135	228815	"U" Cup	A, B & C	1
82	230303	Bell Crank Assembly	A, B & C	1	136	228816	Back-up Washer	A, B & C	1
83	230314	L.H. Side Plate	A, B & C	1	137	228814	Gland Nut	A, B & C	1
84	221716	Front Axle	A, B & C	1	138	223203	Trip Washer	A, B & C	2
85	226614	Front Wheel	A, B & C	2	139	228804	Air Cylinder	A, B & C	1
86	214557	Retaining Ring	A, B & C	2	140	228805	Return Spring	A, B & C	1
87	204324	Washer	A, B & C	2	141	228810	Piston Assembly	A, B & C	1
88	230313	R.H. Side Plate	A, B & C	1	142	228812	Pump Rod	A, B & C	1
89	201789	Lockwasher	A, B & C	2	143	223183	Plug	A, B & C	1
90	203275	Nut	A, B & C	2	144	223678	Pump Packing & Piston	A, B & C	1
91	221704	Spacer Bar	A, B & C	1	145	223187	Valve Plunger	A, B & C	1
92	207164	Nut	A, B & C	2	146	221013	"U" Cup	A, B & C	1
93	211737	Washer	A, B & C	2	147	231347	Piston & Pin Assembly	A, B & C	1
94	230321	Hanger	A, B & C	1	148	221377	Roll Pin	A, B & C	1
95	201478	Lockwasher	A, B & C	2	149	222288	"O" Ring	A, B & C	1
96	203311	Nut	A, B & C	2	150	228813	Washer	A, B & C	1
97	210700	Fulcrum Pin	A, B & C	1	151	223184	Spring	A, B & C	1
98	226318	Grease Fitting	A, B & C	1	152	228235	Hairpin Cotter	A, B & C	1
99	209964	Lockwasher	A, B & C	1	153	228809	Trip Spring	A, B & C	1
100	212622	Bolt	A, B & C	1	154	228806	Spring & Rubber Cushion Assembly	A, B & C	1
101	223179	Hose Clamp	A, B & C	1			Rubber Cushion	A, B & C	1
102	231992	Handle Socket Assembly	A, B & C	1	155	225371	Spring	A, B & C	1
103	226336	Pin	A, B & C	2	156	228807	Screen	A, B & C	1
104	202359	Rivet	A, B & C	2	157	223680		A, B & C	1
105	230323	Set Screw	A, B & C	1	158	203202	Ball	A, B & C	1
106	231993	Handle Socket	A, B & C	1	159	224156	Spring	A, B & C	1
107	213915	Pin	A, B & C	1	160	226373	Adj. Screw	A, B & C	1
108	226334	Roller	A, B & C	1	161	201733	Expansion Plug	A, B & C	1
109	214557	Retaining Ring	A, B & C	2	162	231572	Cylinder Cap	A, B & C	1
110	204324	Washer	A, B & C	2	163	230822	Elbow	A, B & C	1
111	225602	Caster Assy.	A, B & C	2	164	230820	Ear Clamp	A, B & C	1
112	226364	Shoulder Bolt	A, B & C	4	165	230985	Hose Assembly	A, B & C	1
113	231567	Universal Assy.	A, B & C	1	166	223180	Air Valve	A, B & C	1
114	202302	Rivet	A, B & C	1	167	219861	"O" Ring	A, B & C	1
115	226366	Bolt	A, B & C	1					
116	201784	Washer	A, B & C	1					
117	203332	Nut	A, B & C	1					
118	230315	Parallel Link	A, B & C	2					
119	221701	Cap Housing Assembly	A, B & C	1					

A

INSTRUCTIONS

- 1 This unit equipped with automatic vent-filler plug - do not loosen
- 2 **KEEP FILLED WITH OIL** To replenish oil remove the Filler Plug fill with hydraulic jack fluid and replace Filler Plug
Use a clean long-spout oil can to fill reservoir
CAUTION: DO NOT USE BRAKE OR SHOCK ABSORBER FLUID These contain alcohol which is injurious to OIL SEALS
- 3 LUBRICATE ALL MOVABLE JOINTS FREQUENTLY

CAUTION

THIS JACK IS DESIGNED FOR RAISING AND LOWERING LOADS ONLY AFTER RAISING A LOAD ALWAYS USE JACK STANDS TO SUPPORT IT BEFORE GETTING UNDERNEATH IT OR MAKING REPAIRS DO NOT OVERLOAD THE JACK OR JACK STANDS BEYOND THEIR RATED CAPACITIES

FOR YOUR SAFETY

B

**2
TON**

C

93666

D

WALKER

E

WALKER

MODEL	RANGE
<input type="text"/>	<input type="text"/>
SERIES	TONS CAP.
<input type="text"/>	<input type="text"/>

WALKER MANUFACTURING RACINE WISCONSIN

Label Locations

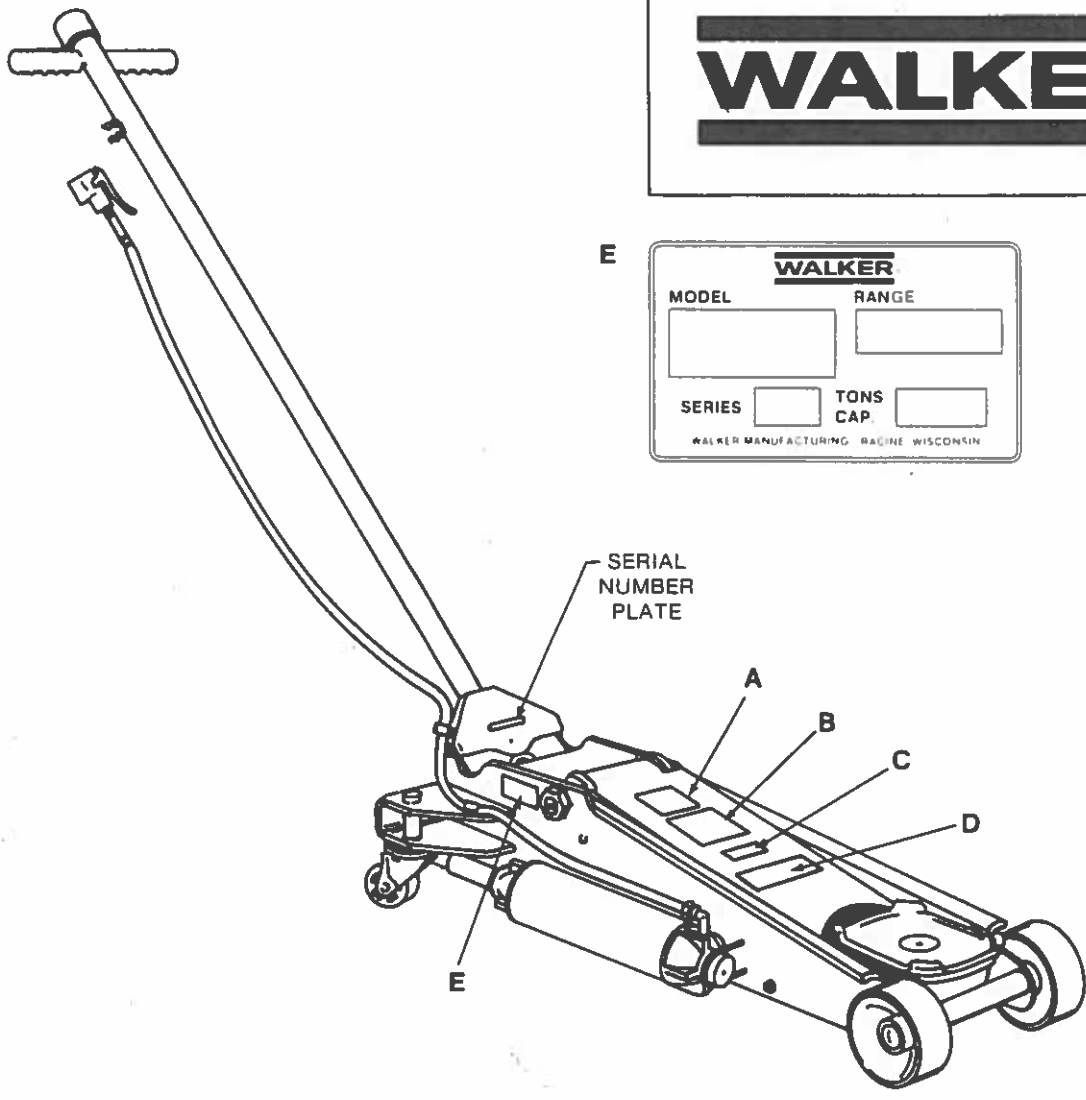

SERVICE ADJUSTMENT PROCEDURE - 230289 AIR HYDRAULIC PUMP

- I. If Air-Hydraulic Jack will not lift but **sounds** normal:
 - A. It is probably air bound. To correct, tip jack on its left side (as viewed from handle end) and cycle the air pump slowly.
 - B. The Hydramatic valve might be stuck open. To check, open release, pull bellcrank up to full height by hand, close the release valve while at full height and let go of the bellcrank. If it returns to low position, the trouble is in the hydraulic unit. If it holds position, lower the jack and try to make a lift with the air pump. If successful, the trouble was in the Hydramatic and raising the bellcrank by hand corrected it.
- II. If Air-Hydraulic Jack will not lift and does **not** sound normal, look for the following:
 - A. If the air pump is cycling unusually fast:
 1. The jack may be air bound.
 2. The suction ball in the hydraulic unit may not be seating.
 - B. If the air pump is not cycling at all, but air can be heard rushing out the exhaust port, the air pump should be removed and checked for the following:
 1. Rubber bumper on cushion spring may have been dislodged from the spring.
 2. The valve plunger assembly 223187 may be stuck open.
 3. The two weep holes in the pump retainer plug 223183 may be plugged with dirt.
 4. The return spring 228805 may be broken.
 - C. If the air pump is not cycling at all and no air is coming out of the exhaust, check for the following:
 1. The pump rod 228812 may be frozen in its packing gland.
 2. The Valve Plunger Assembly 223187 is not opening. Look for a bent Trip Washer or a bent or rusted Valve Plunger which has seized in the piston.
- III. If the jack will raise a load but much more slowly than normal, the trouble is almost certainly related to the air pump. Look for the following:
 - A. If the pump cycles very slowly:
 1. There may be a restriction in the air line between the air valve and the air pump.
 2. One of the weep holes in the 223183 Pump Retainer Plug may be plugged.
 - B. If the pump cycles very rapidly:
 1. The 225384 Trip Spring may be deformed or broken.