

WALKER

**SERVICE
DIVISION**

Jack Parts Sheet

**MODEL 93662
SERIES "A", "B" & "C"**

Retain for file.

10 TON CAPACITY

AIR-HYDRAULIC SERVICE JACK

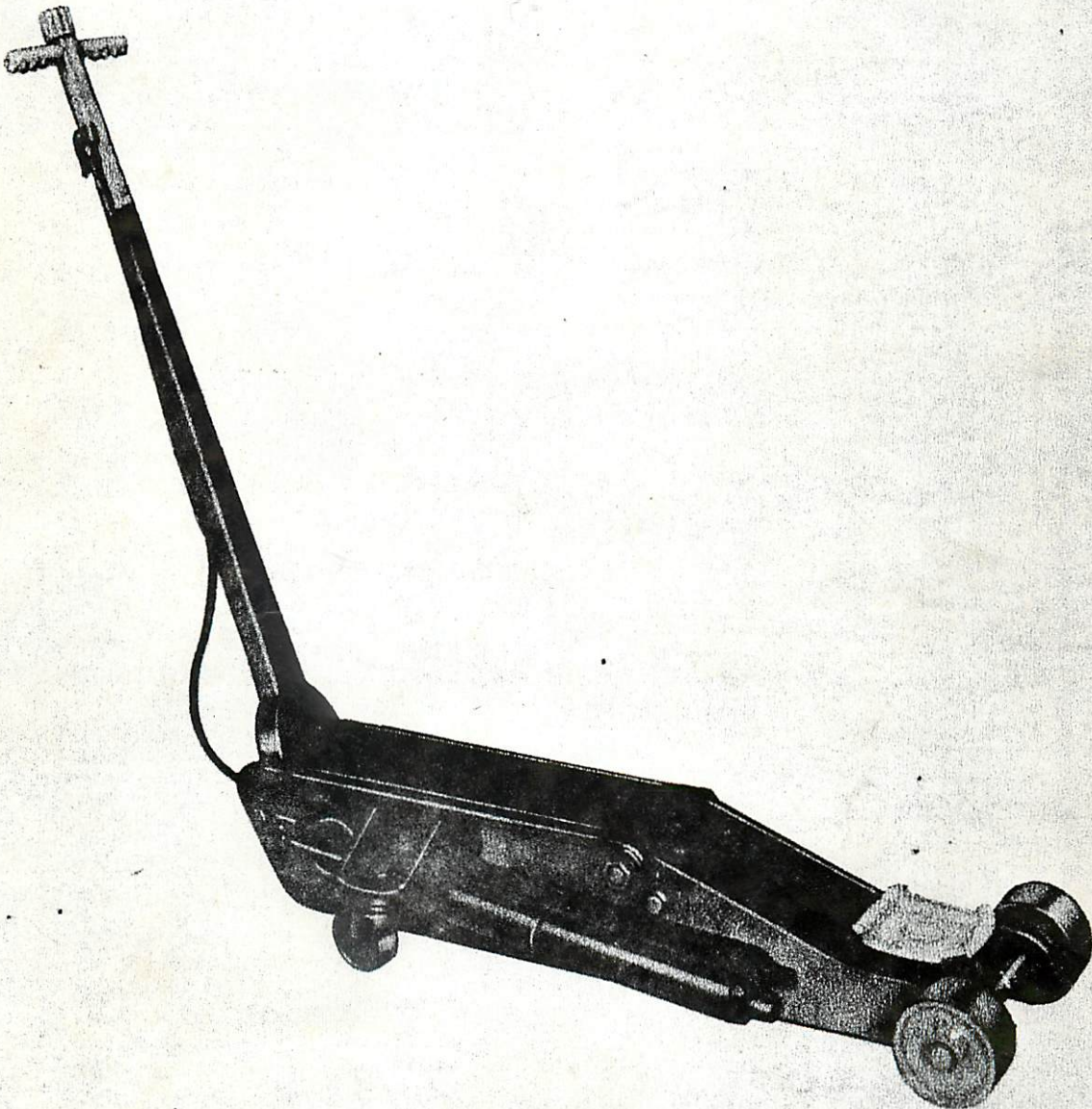

SERVICE

We have Factory-owned BRANCHES AND AUTHORIZED SERVICE DEPOTS located in the principal cities of the United States and Canada. They are operated by FACTORY TRAINED STAFFS and carry a comprehensive stock of REPAIR PARTS. Please contact the Factory or your Walker DISTRIBUTOR for location of Branch or Service Depot nearest you.

Walker Manufacturing GENERAL OFFICE: Racine, Wisconsin — MANUFACTURING PLANT AND SERVICE DEPARTMENT: Jonesboro, Arkansas — FACTORY SERVICE BRANCHES: Atlanta, Georgia — Cleveland, Ohio — Kansas City (Riverside), Missouri — Philadelphia, Pennsylvania — Sacramento, California.

**MODEL 93662
SERIES "A", "B" & "C"**

NOTE: TIGHTEN TO
450-550 FT. LBS.

NOTE: TIGHTEN TO
125-175 FT. LBS.

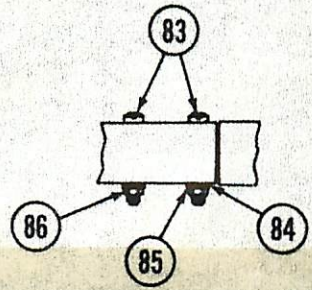
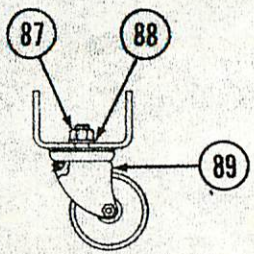
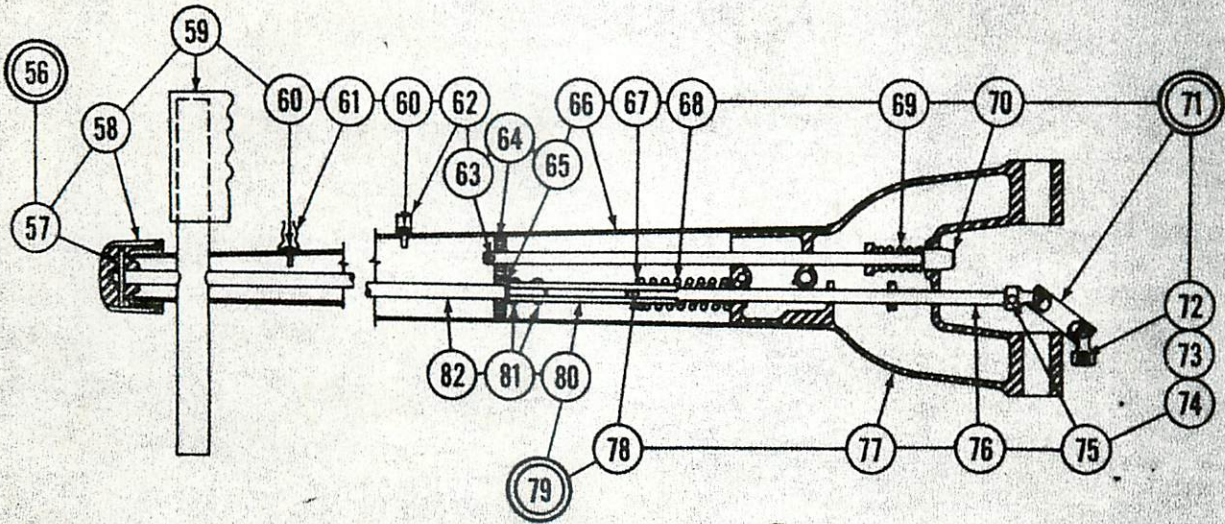
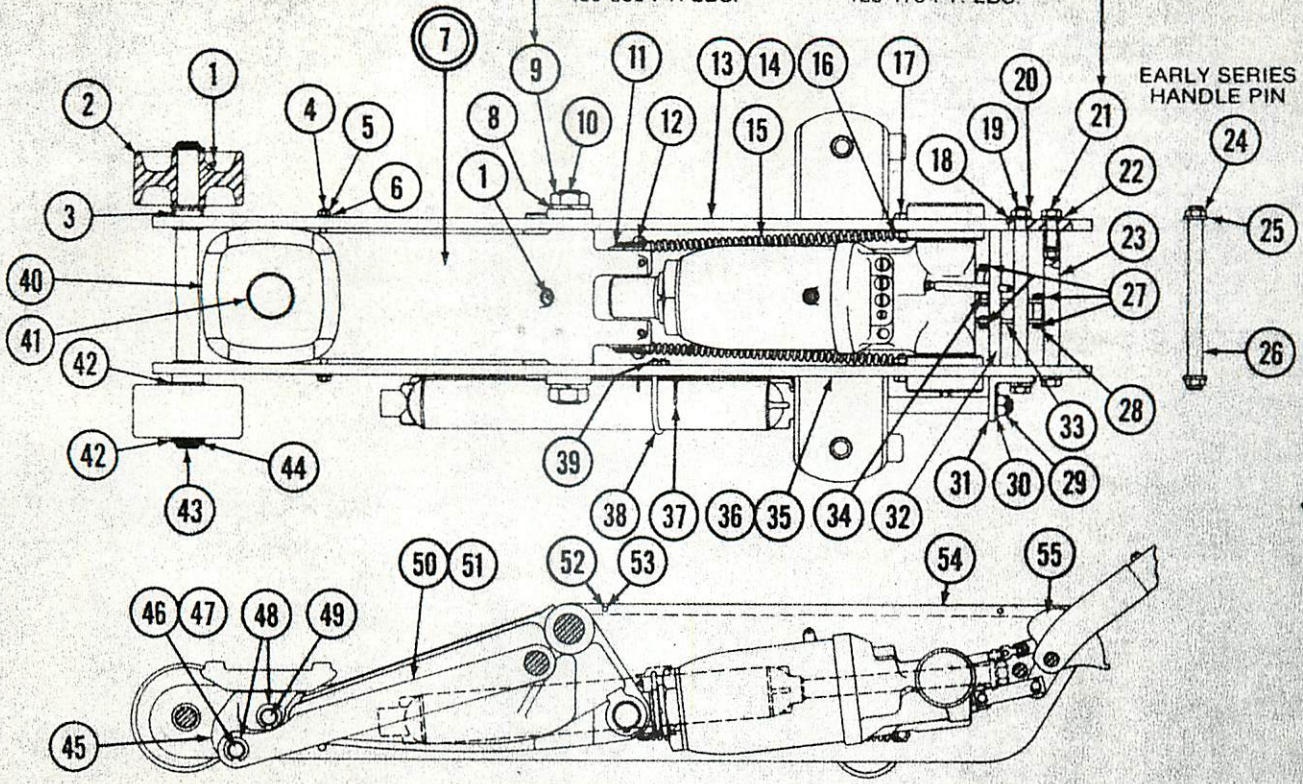

TRI-CITY HYDRAULIC JACK SERVICE
 4628 N. Florida Avenue
 Tampa, Florida 33603-3700
 (813) 236-8551

ORDER BY PART NUMBER, NOT BY CODE NUMBER

MODEL 93662
SERIES "A", "B" & "C"

Code No.	Part No.	Description	Series	No. Req'd	Code No.	Part No.	Description	Series	No. Req'd
1	226318	Grease Fittings	A, B & C	5	46	229936	Pin	A	1
2	231963	Wheel	A, B & C	2	47	231431	Pin	B & C	1
3	217653	Roll Pin	A, B & C	2	48	229947	Retaining Ring	A, B & C	4
4	229938	Pin	A, B & C	1	49	229946	Pin	A, B & C	1
5	207169	Nut	A, B & C	2	50	229941	Parallel Link	A	2
6	201789	Lock Washer	A, B & C	2	51	231430	Parallel Link	B & C	2
7	231474	Lifting Arm Ass'y	A, B & C	1	52	201785	Lockwasher	A, B & C	4
8	201481	Lock Washer	A, B & C	2	53	211567	Screw	A, B & C	4
9	203323	Nut	A, B & C	2	54	229954	Unit Cover	A, B & C	1
10	226271	Fulcrum Pin	A, B & C	1	55	214700	Handle Segment & Bushing	A, B & C	1
11	229910	Retaining Ring	A, B & C	2	56	231990	Handle Ass'y -- Complete	A, B & C	1
12	229933	Pull Back Plate	A, B & C	2	57	221938	Roll Pin	A, B & C	1
13	230012	R.H. Side Plate Ass'y	A	1	58	221937	Release Knob	A, B & C	1
14	231424	R.H. Side Plate Ass'y	B & C	1	59	221809	Handle Grip	A, B & C	2
15	229932	Pull Back Spring	A, B & C	2	60	224081	Screw	A, B & C	2
16	203272	Nut	A, B & C	2	61	223172	Hose Clip	A, B & C	1
17	212689	Bolt	A, B & C	2	62	223179	Hose Clamp	A, B & C	2
18	201110	Lockwasher	A, B & C	2	63	204461	Cotter Pin	A, B & C	1
19	230006	Bumper Pin	A, B & C	1	64	227397	Link	A, B & C	1
20	203299	Nut	A, B & C	2	65	204277	Washer	A, B & C	1
21	231420	Bolt	B & C	2	66	230220	Handle & Cross Bar Ass'y	A, B & C	1
22	201110	Lockwasher	B & C	2	67	204303	Washer	A, B & C	1
23	231419	Handle Fulcrum Pin	B & C	1	68	228875	Spring	A, B & C	1
24	219451	Nut	A	2	69	226372	Spring	A, B & C	1
25	201477	Lockwasher	A	2	70	229952	Plunger Rod & Head Ass'y	A, B & C	1
26	229940	Handle Fulcrum Pin	A	1	71	213704	Universal Ass'y <i>228354</i>	A, B & C	1
27	204444	Cotter Pin	A, B & C	4	72	201784	Lockwasher	A, B & C	1
28	216645	Pin	A, B & C	1	73	203332	Nut	A, B & C	1
29	203301	Nut	A, B & C	1	74	226366	Bolt	A, B & C	1
30	227713	Lockwasher	A, B & C	1	75	211341	Rivet	A, B & C	1
31	230008	Bracket	A, B & C	1	76	229951	Rod	A, B & C	1
32	229929	Universal Support Brg.	A, B & C	1	77	229949	Handle Socket	A, B & C	1
33	226325	Link	A, B & C	2	78	218988	Roll Pin	A, B & C	1
34	210225	Pump Link Spacer	A, B & C	1	79	227436	Turning Rod Ass'y	A, B & C	1
35	230013	L.H. Side Plate Ass'y	A	1	80	227398	Slide Rods	A, B & C	2
36	231425	L.H. Side Plate Ass'y	B & C	1	81	202294	Rivets	A, B & C	2
37	225906	Bracket	A, B & C	1	82	227400	Rod	A, B & C	1
38	230007	Hanger	A, B & C	1	83	200472	Bolt	A, B & C	2
39	226019	Lock Nut	A, B & C	2	84	204270	Washer	A, B & C	2
40	232619	Lifting Cap	A, B & C	1	85	209964	Lockwasher	A, B & C	2
41	232620	Swivel Pin	A, B & C	1	86	203344	Nut	A, B & C	2
42	229912	Washer	A, B & C	4	87	203297	Nut	A, B & C	2
43	229939	Axle	A, B & C	1	88	201115	Lockwasher	A, B & C	2
44	229911	Retaining Ring	A, B & C	2	89	230010	Caster	A, B & C	2
45	229927	Cap Housing	A, B & C	1					



TRI-CITY HYDRAULIC JACK SERVICE

4628 N. Florida Avenue
Tampa, Florida 33603-3700
(813) 236-8551

ORDER BY PART NUMBER, NOT CODE NUMBER
SEE BACK PAGE FOR COMPLETE NUMERICAL LISTING

SERVICE ADJUSTMENT PROCEDURE - 229999 AIR HYDRAULIC PUMP

- I. If Air-Hydraulic Jack will not lift but **sounds** normal:
 - A. It is probably air bound. To correct, tip jack on its left side (as viewed from handle end) and cycle the air pump slowly.
 - B. The Hydramatic valve might be stuck open. To check, open release, pull bellcrank up to full height by hand, close the release valve while at full height and let go of the bellcrank. If it returns to low position, the trouble is in the hydraulic unit. If it holds position, lower the jack and try to make a lift with the air pump. If successful, the trouble was in the Hydramatic and raising the bellcrank by hand corrected it.
- II. If Air-Hydraulic Jack will not lift and does **not** sound normal, look for the following:
 - A. If the air pump is cycling unusually fast:
 1. The jack may be air bound.
 2. The suction ball in the hydraulic unit may not be seating.
 - B. If the air pump is not cycling at all, but air can be heard rushing out the exhaust port, the air pump should be removed and checked for the following:
 1. Rubber bumper on cushion spring may have been dislodged from the spring.
 2. The valve plunger assembly 223187 may be stuck open.
 3. The two weep holes in the pump retainer plug 223183 may be plugged with dirt.
 4. The return spring 223173 may be broken.
 - C. If the air pump is not cycling at all and no air is coming out of the exhaust, check for the following:
 1. The pump rod 231619 may be frozen in its packing gland.
 2. The Valve Plunger Assembly 223187 is not opening. Look for a bent Trip Washer or a bent or rusted Valve Plunger which has seized in the piston.
- III. If the jack will raise a load but much more slowly than normal, the trouble is almost certainly related to the air pump. Look for the following:
 - A. If the pump cycles very slowly:
 1. There may be a restriction in the air line between the air valve and the air pump.
 2. One of the weep holes in the 223183 Pump Retainer Plug may be plugged.
 - B. If the pump cycles very rapidly:
 1. The 225384 Trip Spring may be deformed or broken.