

# PART LIST

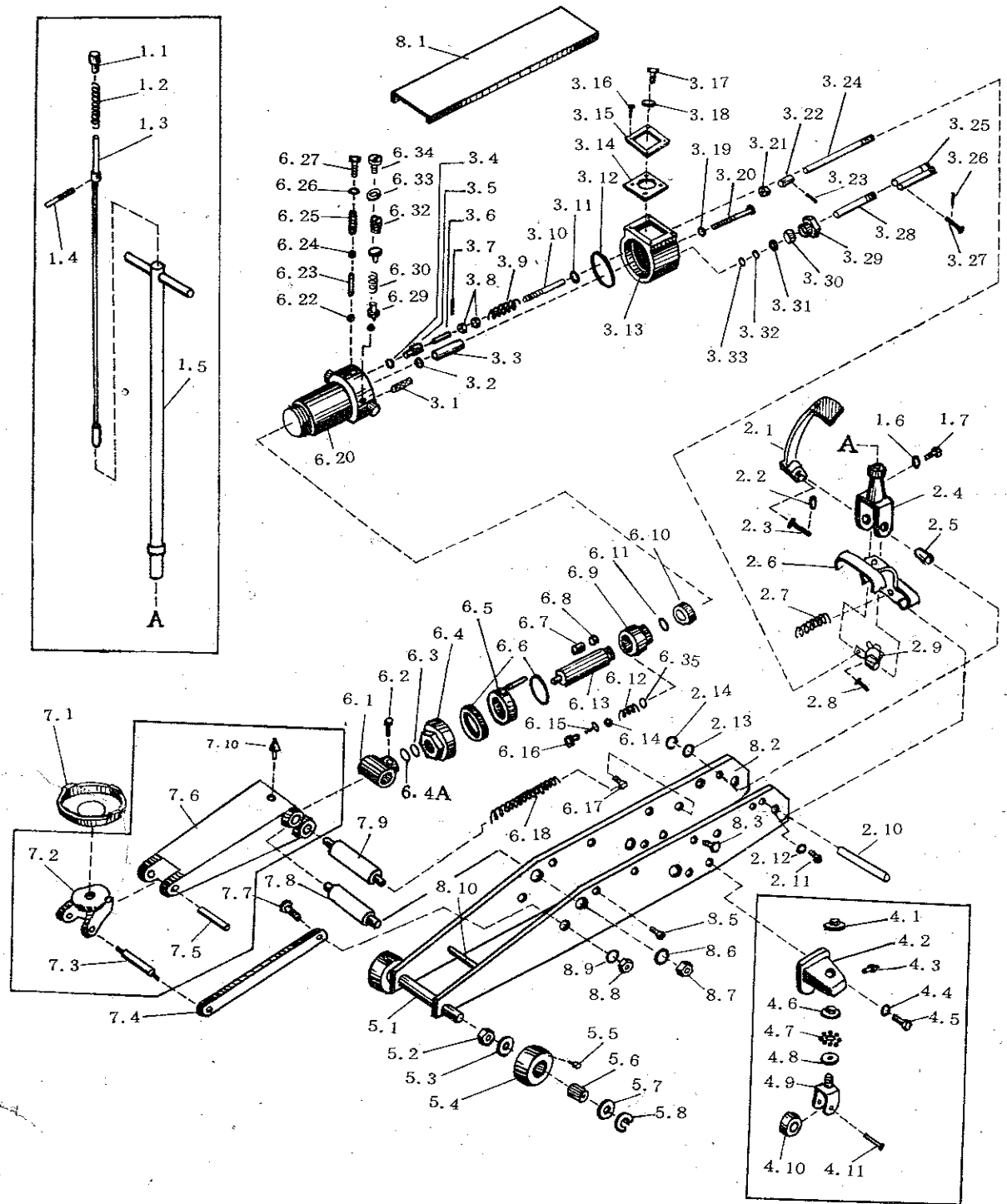

## ATTENDANT SPAIR PARTS

ITEM NO.	DESCRIPTION	PC	ITEM NO.	DESCRIPTION	PC	ITEM NO.	DESCRIPTION	PC
3.32	SEAL RING	1	6.10	RUBBER CUP	1	4.19	SEAL RING	1
3.33	DUST PREVENT RING	1	6.11	STOP RING	1			

Ser: No:	Part name	Ser: No:	Part name	Ser: No:	Part name
1.1	end cover	3.22	connecting bush	6.13	piston rod
1.2	compression spring	3.23	wire	6.14	steel ball
1.3	deflector rod	3.24	connecting rod	6.15	push needle
1.4	screw rod	3.25	driving rod	6.16	valve seat
1.5	control rod	3.26	wire	6.17	screw
1.6	washer	3.27	pin	6.18	spring
1.7	fastening screw	3.28	piston rod	6.19	axle
2.1	foot pedal	3.29	locking nut	6.20	outer body
2.2	circlip	3.30	Protect dust ring	6.22	steel ball
2.3	pin	3.32	seal ring	6.23	small push rod
2.4	fork member	3.33	dust prevent ring	6.24	steel ball
2.5	bush	4.1	cover	6.25	large ball rod
2.6	base	4.2	wheel cover	6.26	washer
2.7	spring	4.3	injecting oil nozzle	6.27	bolt
2.8	pin	4.4	washer	6.4A	Dust prevent ring
2.9	cap	4.5	screw	6.29	valve seat
2.10	shaft	4.6	bearing cover	6.30	spring
2.11	screw	4.7	steel ball		
2.12	washer	4.8	bearing holder	6.32	screw
2.13	washer	4.9	wheel fork	6.33	seal ring
2.14	clamp ring	4.10	wheel	6.34	screw
3.1	filter	4.11	rivet	7.1	tray
3.2	washer	5.1	axle	7.2	joint
3.3	outside tube	5.2	nut	7.3	axle
3.4	washer	5.3	stop ring	7.4	level supporting rod
3.5	valve seat	5.4	wheel	7.5	axle
3.6	needle	5.5	pressure filler port	7.6	rocker
3.7	wire	5.6	roller	7.7	bolt
3.8	nut	5.7	stop ring	7.8	axle
3.9	spring	5.8	split ring	7.9	axle
3.10	screw rod	6.1	joint	7.10	filter
3.11	rubber ring	6.2	screw	8.1	cover plate
3.12	rubber ring	6.3	seal ring	8.2	side plate
3.13	cylinder body	6.4	large nut	8.3	rivet
3.14	paper washer	6.5	ring	8.5	screw
3.15	cover plate	6.6	rubber ring	8.6	washer
3.16	bolt	6.7	bush	8.7	nut
3.17	screw	6.8	seal ring	8.8	nut
3.18	washer	6.9	piston	8.9	washer
3.19	seal washer	6.10	rubber cup	8.10	limiter axle
3.20	bolt	6.11	stop ring	3.31	stop ring
3.21	nut	6.12	spring	6.35	washer

## Technical specification

model	rated load	lift height	height (min)	frame height	distance between wheels	front wheel diameter	back wheel diameter
	TON(kg)				mm (inch)		
QK5-40	5 (5000)	400 (15 3/4")	160 (6 5/16")	210 (8 2/8")	300-400 (11 13/16"-15 3/4")	φ110 (4 5/8")	φ70 (2 25/32")

QK5-40	front wheel width	back wheel width	front axle diameter	net weight	tray diameter	package dimension		
						length	width	height
				kg	mm (inch)	mm (inch)		
	45 (1 25/32")	35 (1 3/8")	φ32 (1 17/64")	102	φ 170 (6 11/16")	1525 (60 3/64")	440 (17 21/64")	255 (9 29/64")

This jack is the important equipment used to maintain the vehicles, agricultural machinery and transport machinery. It has many advantages as following: compact structure, operating convenience, safety and reliability, quick lift.

1. During operation, lift the deflector rod (1) of fluid. return valve per arrowhead indication. Then swing the control rod (2) to start the hand pump, the piston rod of hydraulic cylinder extends out and the elevator mechanism (4) is rised slowly.

2. The wheels (5) should be set on the hard and level ground surface, the load should be put at the centre of the tray (3) After the load is jacked up, the weight must be supported with the reliable jack stand, and then person can start repair under the load.

3. In case of no load, the deflector rod (1) should be set at the neutral position. pump the footpedal (6) to make the elevator mechanism rise slowly.

4. A limiter valve is provided on the piston rod to prevent the piston rod from exceeding its travel range.

5. Take off the fluid filler port cover, fill the hydraulic fluid from the filler port. Maintain sufficient fluid inside the container with the same type and clean fluid.

- Note:
1. The lubricant grease should be applied to the moving positions.
  2. For safety, the load which is lifted by hydraulic cylinder can't exceed the rated Capacity on the label.
  3. When the jack is not used, the elevator mechanism should be lowered down to the lowest position.
  4. The hydraulic jack should be stored at a place being well-ventilated, moist-proof, free from sun light, and corrosion-resistant.

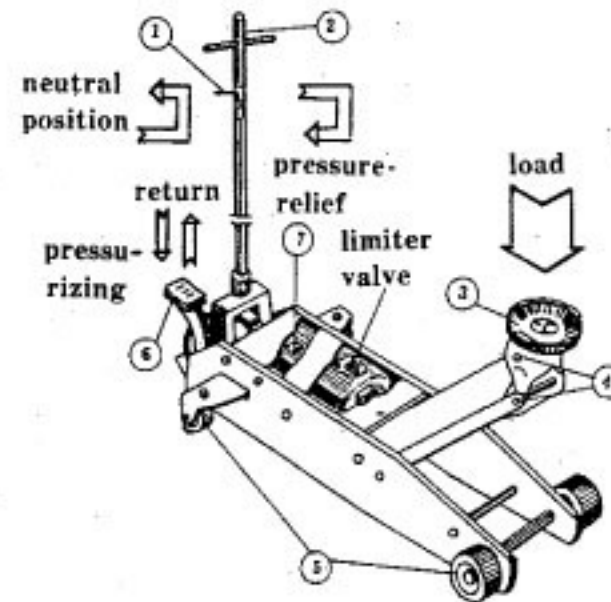

## Operating Instructions and Parts list

QK5-40  
(5 Ton)

and

QK10-40  
(10 Ton)

