

Operator's Manual

TL-A5101



**Plastic Reservoir
Air Hydraulic Pump**

SPECIFICATIONS

Input Air Pressure (psi)	Input Port Threads	Output Port Threads	Oil Delivery(cu.in./min)		Internal Relief Setting (psi)	Usable oil Capacity (cu.in.)	Weight (lbs w/fluid)	L*W*H
			0 psi	10,000 psi				
90-140	1/4-18 NPT	3/8-18 NPT	24.4	7.3	10,000	140	19	12.3"x6.7"x7.5"

DESCRIPTION

This Air/Hydraulic Pump supplies hydraulic fluid pressure to selected tools. It consists of an in-line air and hydraulic cylinder. The ratio of hydraulic fluid pressure generated compared to supply air pressure is 100:1. In other words, 100 PSI out for every 1 PSI in -100 PSI input air pressure equals 10,000 PSI output pressure.

Depressing the RELEASE pedal causes a decrease in pressure and pressing the PUMP end of the pedal provides fluid pressure.

WARNING

The air/hydraulic pump is capable of generating fluid pressure up to 10,000 PSI. Make certain the tool in use is held securely and is in proper working condition. Do not continue to operate the pump once the work is completed. Failure to comply with these instructions could result in personal injury or damage to the equipment.

BEFORE USE

To prevent oil leak during shipment, a metal knob is installed and tightened to ensure the best sealing function. Loosen it counterclockwise before use.

Note: Always secure threaded port connections with non-hardening pipe thread compound. Tighten securely to

prevent accidental removal of components while in use. Take care not to introduce compound into port orifices.

Familiarize yourself with the specifications and illustrations in this operator's manual. Know your pump, its

limitations and how it operates before attempting to use. Refer to Specification chart on above for details of oil

port thread size, usable oil capacity, and more.

OPERATION

Operation of the unit is as follows:

1. Connect the hose of the Air/Hydraulic Pump to the hydraulic coupling on the selected tool.
2. Connect the air supply line to the Air/Hydraulic Pump. Air supply should be 5-10 CFM at 100 PSI to obtain proper operating characteristics. In addition, the air line should be equipped with an air line filter.
3. Stepping on the PUMP end of the pedal engages the pump, producing the force necessary to run the tool.
4. Depressing the RELEASE end of the pump pedal will release the pressure.

MAINTENANCE

1. Inspect hoses and connections daily.
2. Tighten connections as needed. Use non-hardening pipe thread compound when servicing connections.
3. Use only good quality hydraulic fluid. We recommend Mobil DTE 13M or equivalent.

When not in use or during storage:

- a. Depressurize and disconnect hydraulic hoses from application.
- b. Wipe clean, thoroughly.
- c. Store in clean, dry environment. Avoid temperature extremes.
- d. Shield pump with a protective cover.

Adding Hydraulic Fluid

1. Depressurize and disconnect hydraulic hose from application.
2. With pump in its upright, horizontal position, remove the oil filler plug located on the top plate of the reservoir.
3. Use a small funnel to fill reservoir to within 3/4" (19mm) of the opening.

Note: Use only good quality hydraulic jack oil.

Never use brake fluid, transmission fluid, turbine oil, motor oil, alcohol, glycerin etc. Use of other than good quality hydraulic oil will void warranty and damage the pump, hose, and application.

4. Wipe up any spilled fluid and reinstall the oil filler plug.

Changing Hydraulic Fluid

1. For best results, change fluid once a year.
2. Repeat #2 above, then pour used fluid into a sealable container.
3. Dispose of fluid in accordance with local regulations.
4. Fill with a good quality hydraulic jack oil as recommended above. Reinstall vented oil filler plug.

Lubrication

Use a light machine oil to lubricate pivot points, hinges etc.

Note: Never operate pump with release valve closed and disconnected from application. If operated in this condition, the hose and connections become pressurized. This increases burst hazard. Damage may occur to pump and its components.

Parts List of Air/Hydraulic Pump

Item No.	Description	Q'TY	Item No	Description	QTY	Item No	Description	Q"TY
1	oil reservoir	1	31	rear cover		61	screw	12
2	oil filter	1	32	O-ring		62	O-ring	2
3	oil filter		33	O-ring		63	oil filler plug	
4	valve block		34	bolt		64	oil filler plug	
5	screw		35	fixing base	1	65	screw	
6	spring		36	O-ring	2	66	oil filter	
7	ball seat		37	O-ring		67	O-ring	
8	steel ball		38	O-ring		68	O-ring	
9	safety valve		39	spring		69	exhaust muffler	
10	bolt	8	40	ball seat		70	fixing base	
11	copper washer		41	steel ball		71	bolt	4
12	pump cylinder	1	42	O-ring		72	spring	
13	Y-seal		43	nylon gasket	1	73	snap ring	2
14	nylon gasket		44	release valve		74	shaft	
15	copper washer		45	ball seat		75	foot pedal	
16	nut		46	spring		76	O-ring	
17	spring		47	O-ring		77	screw	
18	O-ring		48	release rod		78	air valve	
19	air pump housing		49	O-ring	4	79	spring	
20	washer	1	50	steel ball		80	seal	
21	pump plunger	1	51	spring		81	bolt	2
22	air piston base		52	steel ball		82	air valve rod	
23	O-ring	2	53	spring	1	83	O-ring	
24	air shuttle valve		54	O-ring		84	O-ring	
25	O-ring	2	55	nylon gasket		85	seitch coupler	
26	piston		56	coupler				
27	bolt	3	57	nylong gasket				
28	shuttle valve seal		58	O-ring				
29	O-ring	2	59	seal				
30	O-ring	1	60	cover				

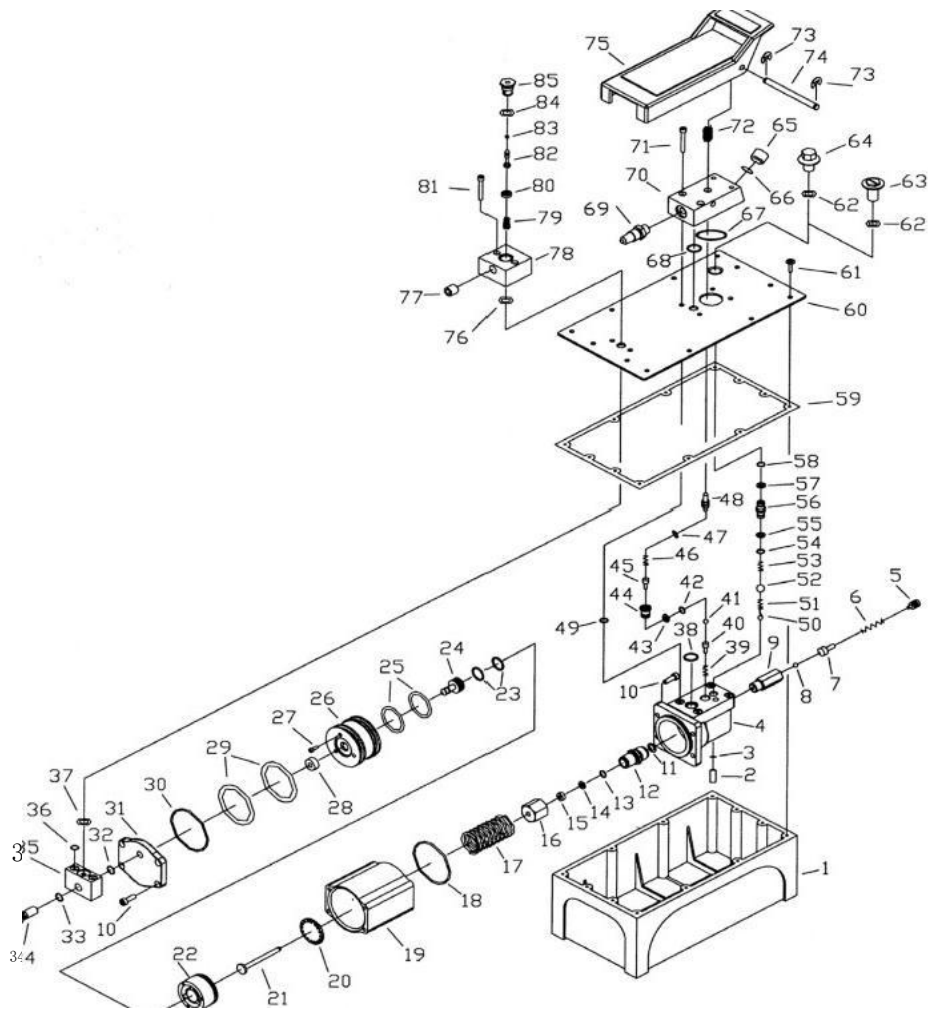

TROUBLESHOOTING

Symptom	Possible Causes	Corrective Action
Application will not extend, move or respond to pressurized fluid	<ul style="list-style-type: none"> ·Overload condition ·Release valve not closed 	<ul style="list-style-type: none"> ·Remedy overload condition ·Ensure release valve closed
Application responds to pressurized fluid, but system does not maintain pressure	<ul style="list-style-type: none"> ·Overload condition ·Release valve not closed ·Hydraulic unit malfunction 	<ul style="list-style-type: none"> ·Remedy overload condition ·Ensure release valve closed
Application will not return fluid to pump (i.e. cylinder will not retract)	<ul style="list-style-type: none"> ·Malfunctioning coupler ·damaged application ·Reservoir overfilled 	<ul style="list-style-type: none"> · Secure load by other means. Open release valve, depressurize pump and hose, remove coupler and/or application, then renew or replace · Secure load by other means. Open release valve, depressurize pump and hose, remove application, then drain fluid to proper level
Application will not fully extend (cylinder or spreader)	<ul style="list-style-type: none"> ·Fluid level low ·Fluid level low 	<ul style="list-style-type: none"> ·Follow Symptom 3 procedure for securing load, depressurizing pump, remove application, then ensure proper fluid level
Poor performance	<ul style="list-style-type: none"> ·Air trapped in system 	<ul style="list-style-type: none"> ·Ensure proper fluid level ·Ensure vented oil filler plug let pressurized reservoir air escape (see Before Use)