

## OWNER'S MANUAL

### CONTENTS:

Page 1 Specifications  
 2 Safety Information and Warranty Information  
 3 Parts List  
 4 Pump Assembly Instructions  
 5-6 Winch Kit Parts List and Winch Installation Instructions  
 7 Ram Assembly Instructions  
 8 Ram Operating Instructions  
 9 Replacement Parts List  
 10-12 Notes

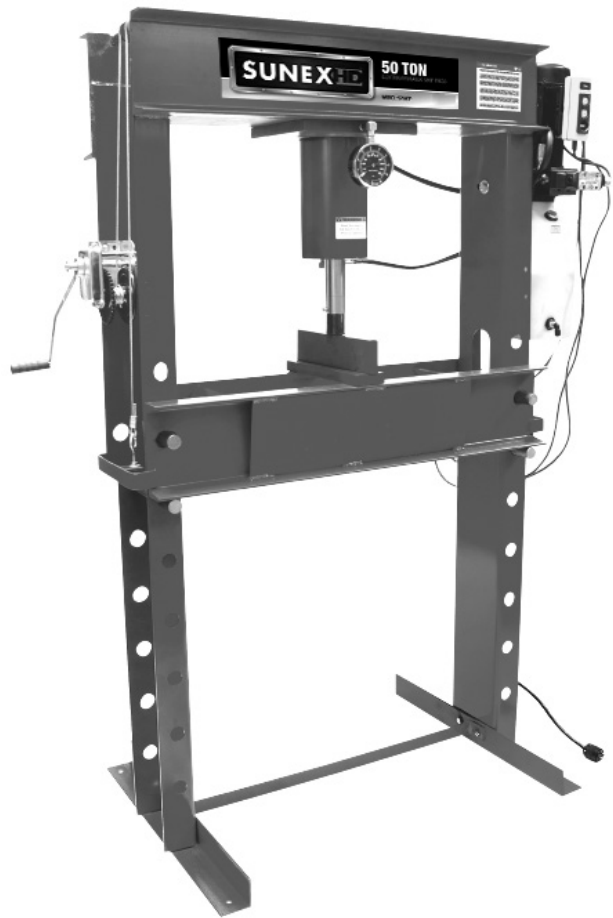
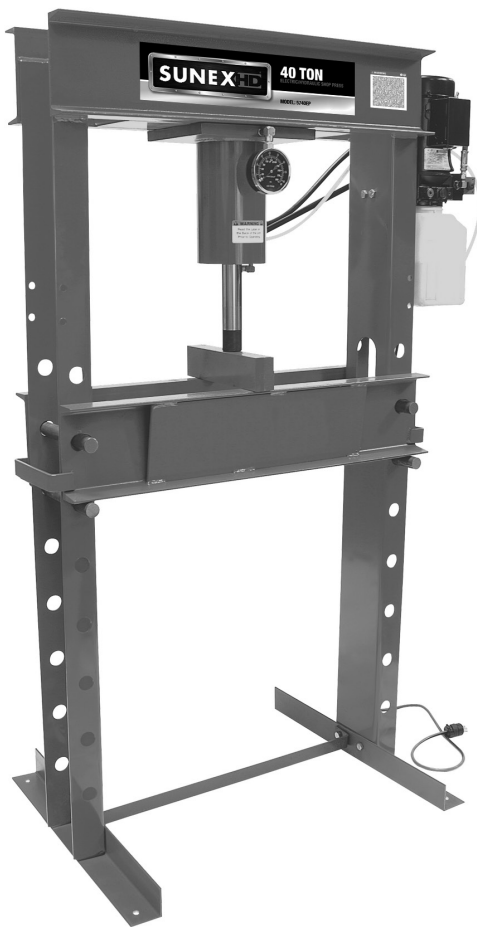

### PRESS SPECIFICATIONS

Sunex Model No.	A	B	C	D	E	F	G	H	I	J	K	L
5740EP	76.25"	32"	29.75"	12"	8.25"	1.25"	1 HP Pendant Remote	9.5/14 AWG	Emerson 115V/13.2 AMPS	N	N	Y(2)
5750EP	74"	35"	29.75"	13"	8"	1.25"	2 HP Pendant Remote	9.5/14 AWG	Emerson 115V/13.2 AMPS	Y	N	Y(2)

A - Total Height  
 B - Inside Width  
 C - Press Feet Length  
 D - Bed Width  
 E - Stroke (Ram Travel Distance From Fully Retracted Position To Fully Extended Position)  
 F - Pin Diameter

G - Motor Control  
 H - Power Cord (Length/Type)  
 I - Mfr/Volts/Amperes (Electric Motor)  
 J - Pb Winch  
 K - Sliding Head  
 L - Press Plates Included

### SAFETY INFORMATION



THIS OPERATING MANUAL CONTAINS IMPORTANT SAFETY INFORMATION. READ CAREFULLY AND UNDERSTAND ALL INFORMATION BEFORE OPERATING THIS TOOL. SAVE THIS MANUAL FOR FUTURE USE.

#### WARNING

This symbol alerts you to the possibility of serious injury or death if instructions are not followed.

#### CAUTION

This symbol alerts you to the possibility of damage to or destruction of equipment if instructions are not followed.

#### WARNING

Failure to heed these warnings may result in loss of load, damage to the press and/or failure resulting in property damage, personal or fatal injury. This operating manual contains important details concerning the safe operation of this tool. The user must read and understand these details before any use of the tool. This manual must be retained for future reference.

- Read, study, understand and follow all instructions before operating this press.
- Always wear safety goggles, (users and bystanders).
- Parts being pressed may splinter, shatter, or be ejected from the press at a dangerous rate of speed. Because there are a variety of press applications, it is the responsibility of the press owner to provide adequate guards, eye protection and protective clothing to the press operator.
- Visual inspection of the press should be made before use, checking for signs of cracked welds, bent bed pins, loose or missing bolts, leaks, or any other structural damage. Corrections must be made before using the press.
- Do not go near leaks. High pressure hydraulic fluid can puncture skin and cause serious injury, gangrene, or death. If injured, seek emergency medical help as immediate surgery is required to remove the fluid.
- Prior to use make sure the press is securely anchored to a concrete floor.
- Keep hands, arms, feet, and legs out of work area. Accidental slippage can result in personal injury.
- Always use an accurate force gauge to measure pressing force.
- Do not exceed the rated capacity or tamper with the pressure/force settings. When attachments and adapters are used the rated capacity of the system shall be no greater than the rated capacity of the lowest rated component or combination of components that make up the system.
- Avoid off-center loads. Offset loads can damage ram and may cause load to eject at a dangerous rate of speed. Do not use any spacer or extender between the press ram plunger and the item being pressed. If there is not enough ram stroke, adjust the height of the movable bolster.
- Remove all loads from movable bolster before attempting to adjust bolster height. Beware of possible falling bolster.
- Press only on loads supported by movable bolster and press plates included. Do not support loads on floor or press frame legs.
- When using any accessories such as press plates or arbor plates, be certain they are centered on the movable bolster and in full contact with both sides of the bolster.
- Before applying load, be certain all movable bolster supporting pins are fully engaged. Verify lift cables (if equipped) are slack before pressing on the bolster.
- Always use a bearing shield when pressing bearings.
- Use caution when positioning work to be pressed to ensure the item to be pressed cannot be ejected at a dangerous rate of speed.
- Release hydraulic pressure before loosening any fittings.
- Maintain proper hydraulic fluid levels.
- Do not make any alterations or modifications to the press.
- Failure to heed and understand these markings may result in serious or fatal personal injury and/or property damage.

**WARNING:** This product can expose you to chemicals including nickel, which is known to the State of California to cause cancer and birth defects or other reproductive harm. For more information go to [www.P65Warnings.ca.gov](http://www.P65Warnings.ca.gov).

#### OWNER/USER RESPONSIBILITY

The owner and/or user must have an understanding of the manufacturer's operating instructions and warnings before using this press. Personnel involved in the use and operation of equipment shall be careful, competent, trained,

and qualified in the safe operation of the equipment and its proper use when servicing motor vehicles and their components. Warning information should be emphasized and understood.

If the operator is not fluent in English, the manufacturer's instructions and warnings shall be read to and discussed with the operator in the operator's native language by the purchaser/owner, making sure that the operator comprehends its contents.

Owner and/or user must study and maintain for future reference the manufacturer's instructions. Owner and/or user is responsible for keeping all warning

labels and instruction manuals legible and intact. Replacement labels and literature are available from the manufacturers.

#### INSPECTION

Visual inspection of the shop press should be made before each use of the press, checking for damaged, loose or missing parts. Each press must be inspected by a manufacturer's repair facility immediately, if subjected to an abnormal load or shock. Any press which appears to be damaged in any way, is found to be badly worn, or operates abnormally must be removed from service until necessary repairs are made by a manufacturer's authorized repair facility. It is recommended that an annual inspection of the press be made by a manufacturer's authorized repair facility and that any defective parts, decals or warning labels be replaced with manufacturer's specified parts. A list of authorized repair facilities is available from the manufacturer.

#### SAFETY INSTRUCTIONS

- CHECK YOUR LOCAL, STATE AND FEDERAL REGULATIONS REGARDING THE SAFE USE OF THIS EQUIPMENT.
- Your safety is top priority. Please handle equipment with care.
- Fully retract unit and remove all items from the press bed frame.
- Support the press bed, and remove the pins.
- Raise or lower bed to desired height and reinstall press pins. Be certain pins are fully engaged in the parallel flanges of the upright columns.
- Position press on a flat, level, hard surface, preferably concrete. Make sure all nuts and bolts are tight.
- Clear the area of bystanders, especially small children, before using.
- Set the press bed to the required height. The press is most effective when the work piece is located 1 inch below the ram's retracted position. The compression stroke can include the entire 5 inch working range.
- The press is designed to exert a force on anything which is positioned beneath its ram. The work piece can pop out from under the ram at a high rate of speed and injure someone.
- Pressing Bearings: It is essential that you use the bearing shield when pressing bearings on or off.

#### LIMITED WARRANTY:

SUNEX INTERNATIONAL, INC. WARRANTS TO ITS CUSTOMERS THAT THE COMPANY'S SUNEX TOOLS<sup>®</sup> BRANDED PRODUCTS ARE FREE FROM DEFECTS IN WORKMANSHIP AND MATERIALS.

Sunex International, Inc. will repair or replace its Sunex Tools<sup>®</sup> branded products which fail to give satisfactory service due to defective workmanship or materials, based upon the terms and conditions of the following described warranty plans attributed to that specific product. This product carries a ONE-YEAR warranty. During this warranty period, Sunex Tools<sup>®</sup> will repair or replace at our option any part or unit which proves to be defective in material or workmanship.

#### Other important warranty information....

This warranty does not cover damage to equipment or tools arising from alteration, abuse, misuse, damage and does not cover any repairs or replacement made by anyone other than Sunex Tools<sup>®</sup> or its authorized warranty service centers. The foregoing obligation is Sunex Tools<sup>®</sup> sole liability under

this or any implied warranty and under no circumstances shall we be liable for any incidental or consequential damages. **Note: Some states do not allow the exclusion or limitation of incidental or consequential damages, so the above limitation or exclusion may not apply to you.**

Return equipment or parts to Sunex Tools<sup>®</sup>, transportation prepaid. Be certain to include your name and address, evidence of the purchase date, and description of the suspected defect.

If you have any questions about warranty service, please write to Sunex Tools<sup>®</sup>. This warranty gives you specific legal rights and you may also have other rights which vary from state to state. Repair kits and replacement parts are available for many of Sunex Tools<sup>®</sup> products regardless of whether or not the product is

still covered by a warranty plan.

#### SHIPPING ADDRESS:

Sunex Tools  
315 Hawkins Rd.  
Travelers Rest, South Carolina 29690  
29608

#### MAILING ADDRESS:

Sunex Tools  
P.O. Box 4215  
Greenville, South Carolina

## PARTS LIST

ESTIMATED ASSEMBLY TIME: 45 MINUTES

Press Frame - 1

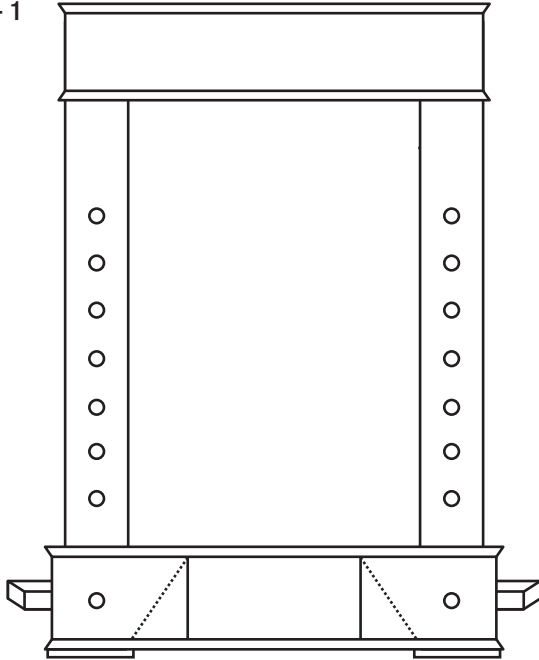

1/2"-13 x 1-1/8" Hex Head Bolts - 2  
 For Pump Assembly



1/2" Nuts - 2  
 For Pump Assembly



1/2"-13 x 3/4" Hex Head Bolts - 4



Washers - 6



Pump and Ram Assembly - 1

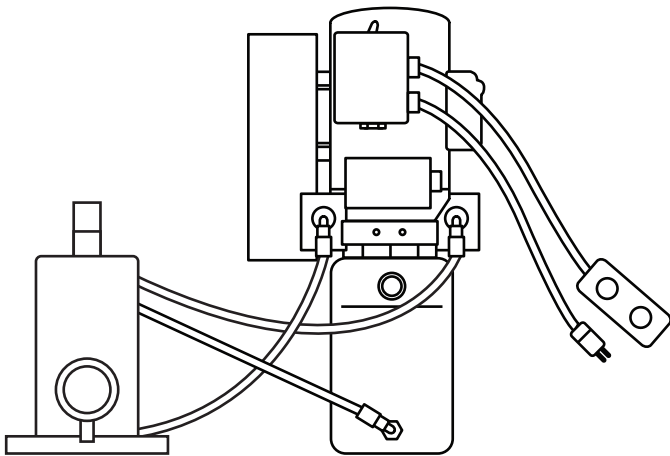

Air Breather Cap - 1

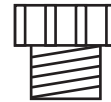

1-1/4" x 14" Press Pins - 4

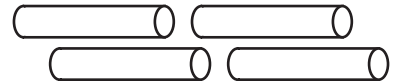

## ACCESSORIES

Press Plates - 2  
 Accessory only -  
 Not needed for assembly

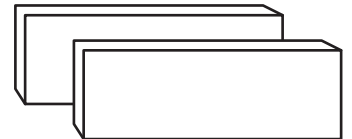

## TOOLS NEEDED

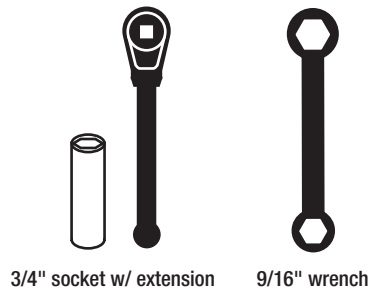
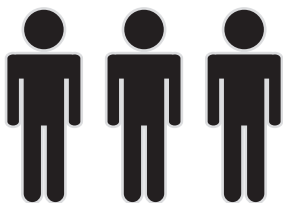

3/4" socket w/ extension      9/16" wrench

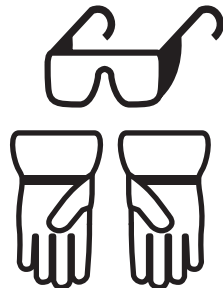

**YOU WILL NEED A FORKLIFT AND AT LEAST 3 PEOPLE TO PROPERLY ASSEMBLE THIS PRESS. OPERATION OF THE FORKLIFT SHOULD BE PERFORMED BY A LICENSED PROFESSIONAL ONLY. BE SURE TO USE EXTREME CAUTION WHEN ASSEMBLING THIS PRESS, AS YOUR SAFETY IS TOP PRIORITY.**

## PUMP ASSEMBLY INSTRUCTIONS

**3**

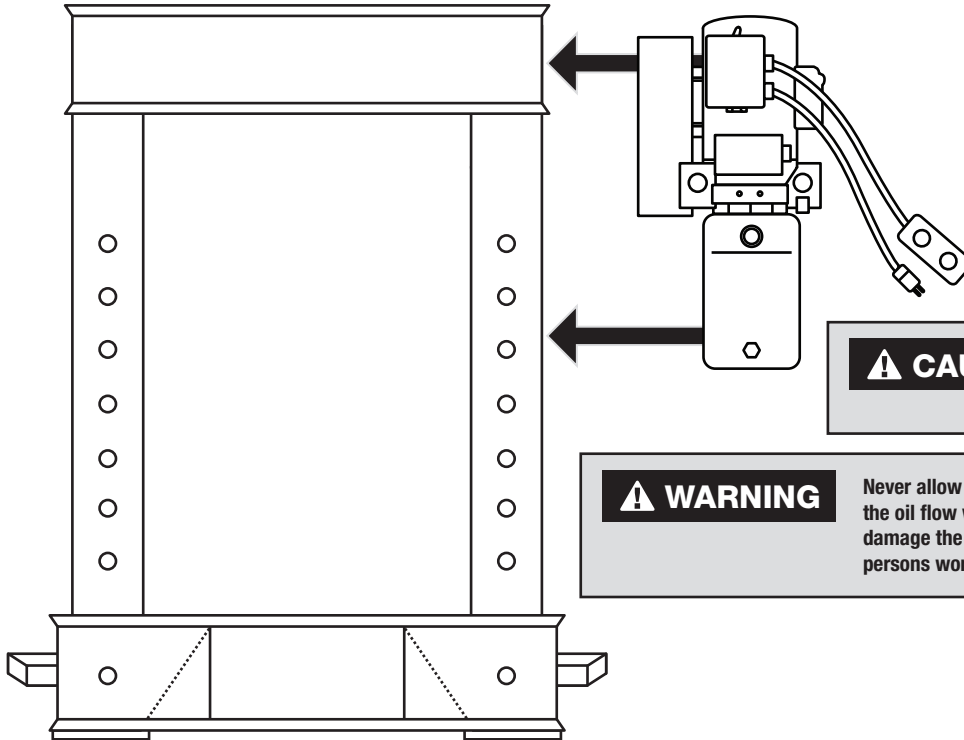

Using at least two people, lift the pump assembly off of the forklift and orient the pump so that the plastic tank is on the bottom. Align with holes on right side of press frame.

Using the 1/2"-13 x 1-1/8" hex head bolts, nuts and washers provided, attach the pump assembly to the press frame. (Line up a bolt and a washer in the inside of the frame first. Finish with the nut attached under the pump assembly. Repeat with other hole.)

### **CAUTION**

All hoses should run **BEHIND** press frame and should be free of kinks, twists or bends.

### **WARNING**

Never allow hoses to kink, twist, curl or bend so tightly that the oil flow within the hose is blocked or reduced. This could damage the hose and possibly result in serious injury to persons working in the immediate vicinity.

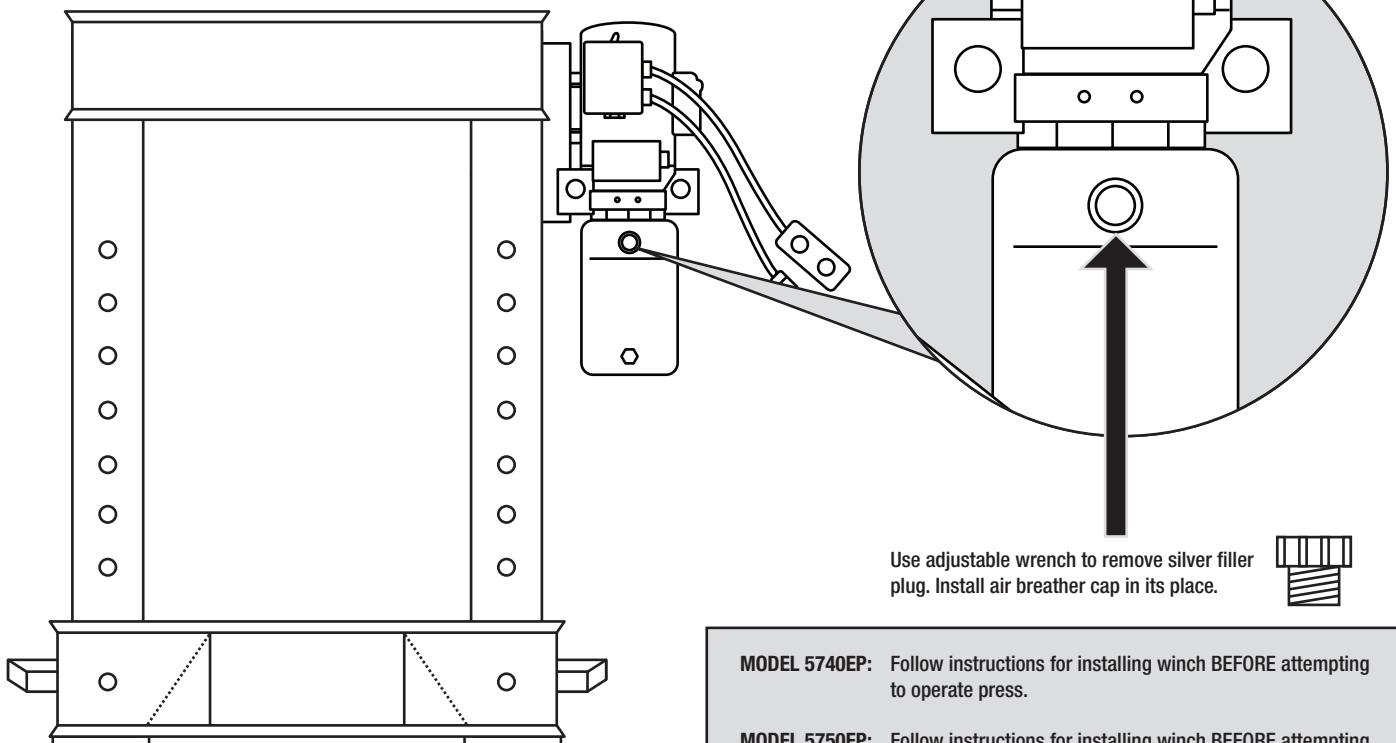







Use adjustable wrench to remove silver filler plug. Install air breather cap in its place.

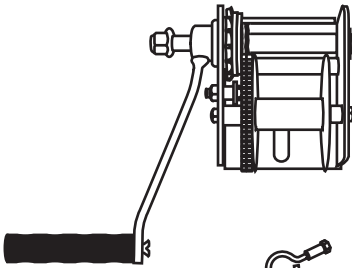

**MODEL 5740EP:** Follow instructions for installing winch **BEFORE** attempting to operate press.

**MODEL 5750EP:** Follow instructions for installing winch **BEFORE** attempting to operate press.

## WINCH KIT PARTS LIST 5250EP ONLY

Winch - 1		Cable Clamp - 1	
Long Cable - 1		1/2"-13 x 1-1/2" Hex Head Bolts - 2	
Short Cable - 1		1/2" Nuts - 2	
		Washers - 2	

## WINCH INSTALLATION INSTRUCTIONS

**1**

-  Dark Gray- Long Cable
-  Light Gray- Short Cable

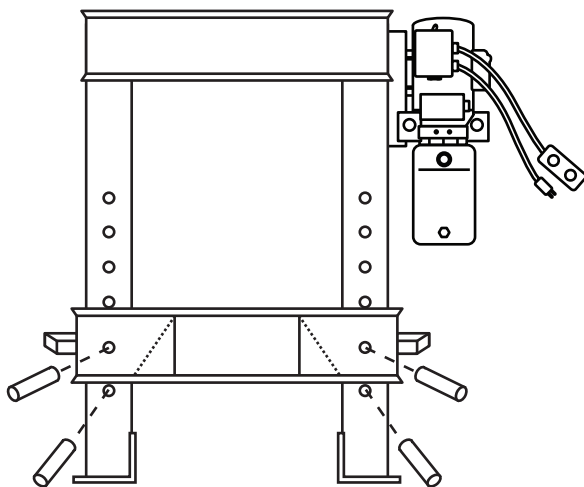

1. Move press bed into **LOWEST** position and insert all 4 press pins.

Right side of press,  
under pump assembly

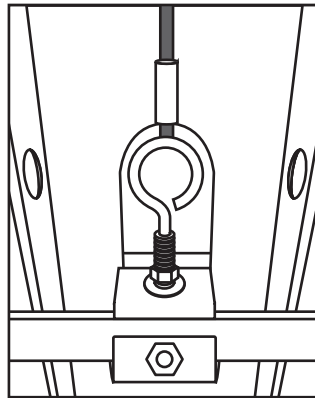

2. Install pre-attached eye bolt on **LONGER** cable to press bed handle located *under pump assembly*. **DO NOT FULLY TIGHTEN.** Center with side of press bed and make sure there is enough room to lower or raise both nuts on eye bolt for precise alignment.

Right side of press

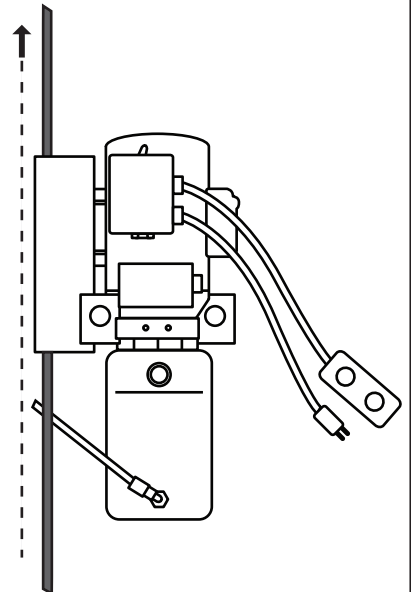

3. Thread the **BARE** end of the **LONGER** of the two steel cables up and through the pump assembly.

### **WARNING**

ALL FOUR (4) pins must be **COMPLETELY** through to **BOTH SIDES** of frame in order to operate press.

### **WARNING**

**DO NOT FULLY TIGHTEN.**

**Note:** Refer to manual from winch manufacturer for detailed instructions on winch assembly and cable threading procedure.

**WINCH INSTALLATION INSTRUCTIONS CONTINUED**

**2**

LONG CABLE top view of press

**⚠ WARNING**  
Mount winch to frame  
AFTER threading cable.

This end feeds into winch.

- Run the long cable up and OVER BOTH ROLLER BRACKETS and feed into winch. Be sure and thread 12 inches (1 foot) of extra cable through winch.
- Once winch cable has been threaded, pull excess cable back through winch as shown in diagram above. The cable should be locked tightly around itself with no excess cable left hanging. Operate winch enough to remove slack from longer cable.
- Mount winch to frame using the provided washers, 1/2" nuts and 1/2"-13 x 1-1/2" bolts.

Top view of press with bed in lowest position

- Feed the short cable by running it up and OVER first roller, then UNDER second roller. Loop the short cable back toward the winch and securely attach to the longer cable using the cable clamp. Remove slack from short cable before securing to long cable. Clamp should be NO LESS THAN ONE INCH (1") from roller.

Left side of press, under winch

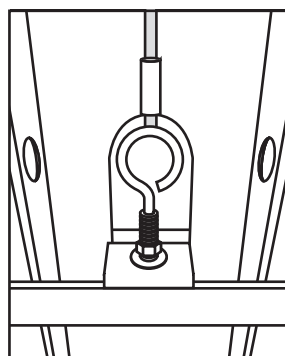

- Install pre-attached eye bolt on SHORTER cable to press bed handle located under winch *after feeding it around in step 7.*
- Turn eye hooks to adjust and level press bed. Once bed is level, firmly tighten eye hook mounting hardware. The steel cable will stretch with use. It may be necessary to repeat this leveling procedure in the future.
- Test the winch kit by raising and lowering the press bed from its lowest to highest position. Repeat and adjust until bed is level and moves freely throughout its entire range of motion. Cut excess cable when all adjustments are complete.

**SHIPPING ADDRESS:**  
 Sunex Tools  
 315 Hawkins Rd.  
 Travelers Rest, South Carolina 29690

**MAILING ADDRESS:**  
 Sunex Tools  
 P.O. Box 4215  
 Greenville, South Carolina 29608

## RAM ASSEMBLY INSTRUCTIONS

1

### ⚠ WARNING

The press must be on a hard, flat surface, bolted to the floor if necessary in the position in which it will remain for the life of the equipment.

**Note:** Handle ram carefully to avoid damage to gauge or gauge face. Do not disconnect hoses prior to assembly.

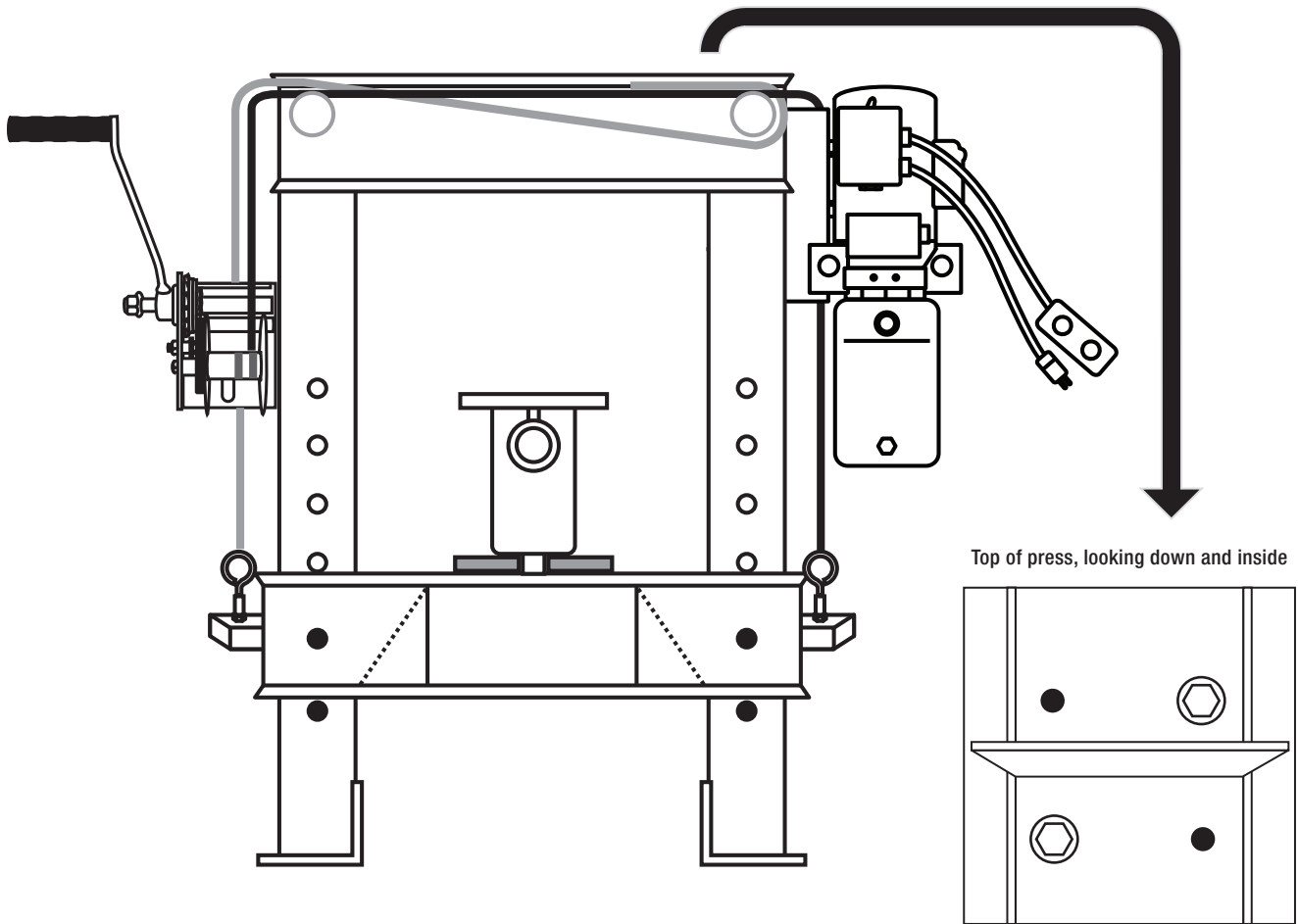

1. Arrange Press Plates on Press Bed with Ram sitting on top of the Press Plates. The Ram should be upside down with the gauge facing forward. Securing the Ram, raise the Press Bed using the Winch until the ram is touching the top of the frame.

3. When Ram is secured to the frame, attach color coded hoses to the corresponding color coded ports. Using the winch, Lower Press Bed and insert Press Pins at desired height.

2. TO BOLT RAM TO PRESS, stand on a sturdy ladder and look down into press from the top. Use the provided 1/2-13 x 3/4" hex head bolts and washers, offsetting the first two bolts and washers for more precise alignment. Finish with the other two bolts and washers until the ram is completely secured to the press frame. *These four bolts will thread directly into pre-tapped holes in the ram.*

## RAM OPERATING INSTRUCTIONS

1. Check to ensure all connections are secure and all bolts and nuts are tightened.
2. Place press plates DIRECTLY under ram, on press bed. ALWAYS center load and press blocks.
2. Plug in the pump assembly.
3. Flip switch on top of pump assembly.
4. Use remote to operate ram.
5. Pump should now operate normally. Repeat steps 1-4 if necessary.

**Note:** Sometimes the ram moves in the opposite direction of the arrows on the remote. Do not be alarmed if this happens, as it is commonplace in the initial wiring. Make a note if this does occur. You may reverse your hydraulic lines on either pump or ram. Move the ram up and down accordingly.

**Note:** The remote control is magnetic and will stick to the steel press frame when not in use.

### **⚠ WARNING**

Do not allow the ram to extend more than 6.125" (6-1/8").

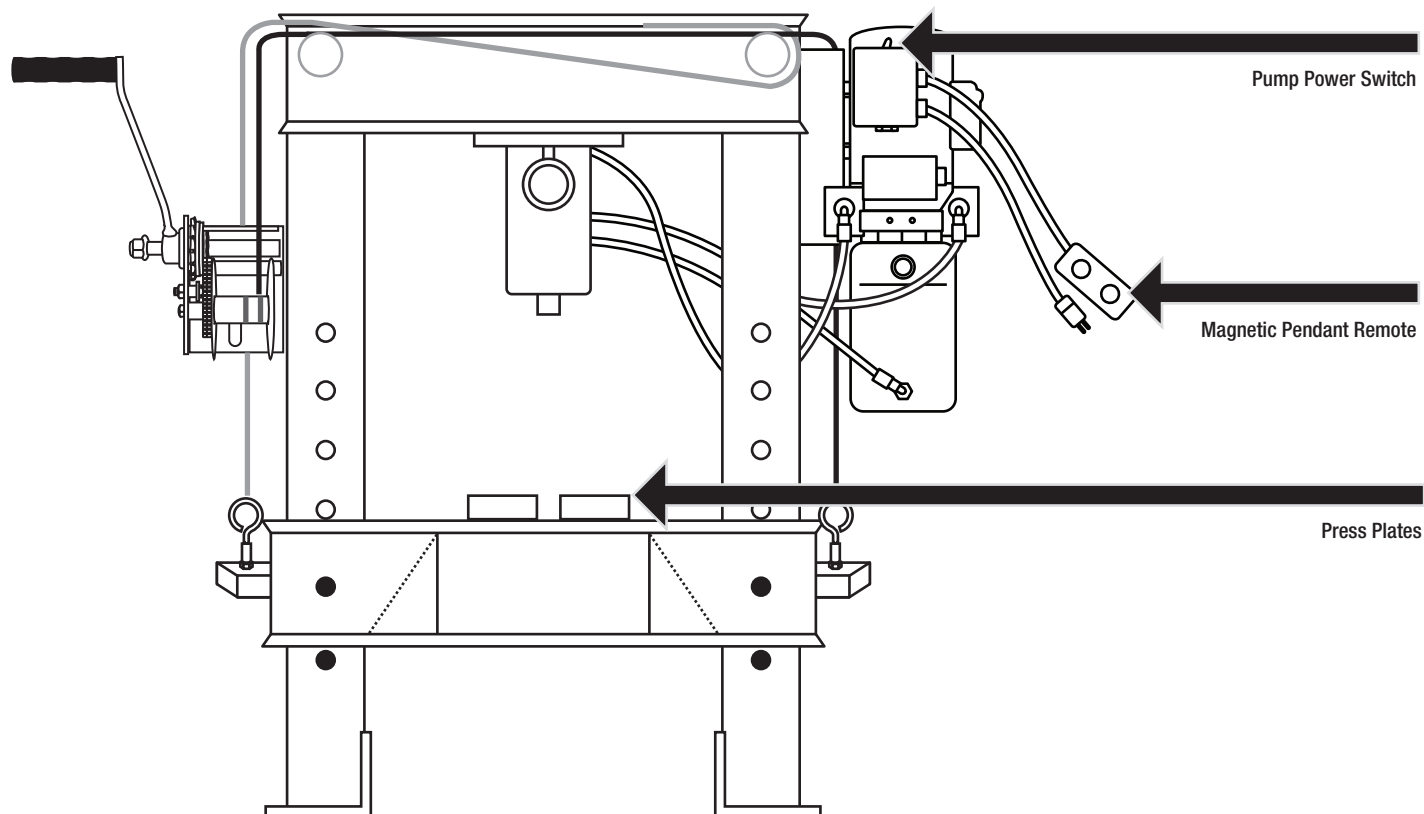



## REPLACEMENT PARTS LIST

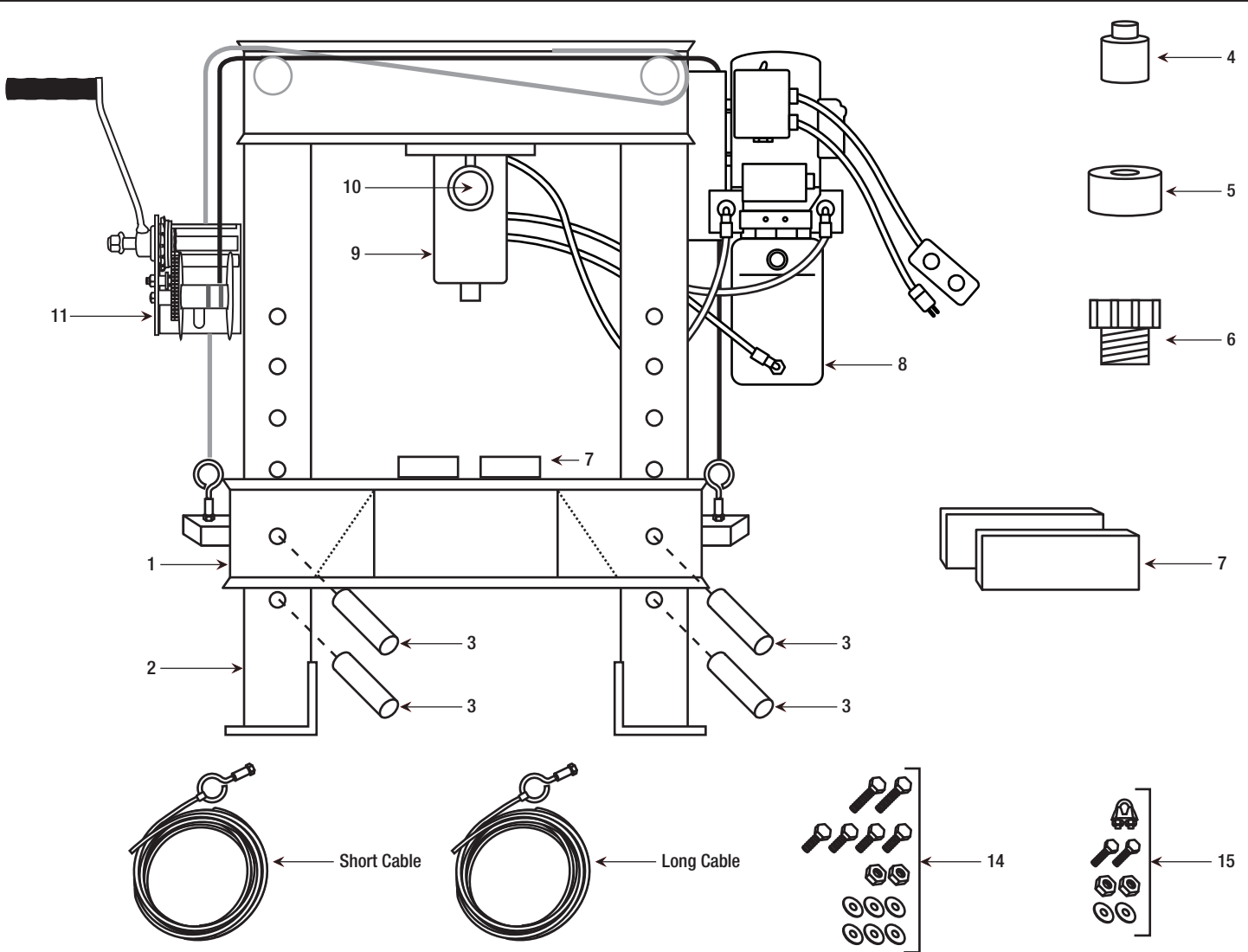

ITEM NO.	SUNEX PART NO.	DESCRIPTION	QTY.	ITEM NO.	SUNEX PART NO.	DESCRIPTION	QTY.
1		Press Bed	1	11	RS4050WCH	Winch	1
2		Press Frame	1	14	RS40MPPHK	Press Hardware Kit	1 set
3	RSCBP1225	Press Pin	4			1/2"-13 x 1-1/8" Hex Head Bolt	2
4	RS345009	Pushing Adapter	1			1/2"-13 x 3/4" Hex Head Bolt	4
5	RSBS1	Bearing Shield	1			1/2" Nut	2
6	RS4050ABC	Air Breather Cap	1			Washer	6
7	RSCBP1205	Press Plate	2	15	RSWHK	Winch Hardware Kit	1 set
8	RS40EPP	Pump (5740EP)	1			Cable Clamp	1
	RS50EPPP	Pump (5750EP)	1			1/2"-13 x 1-1/2" Hex Head Bolt	2
9	RS40EPR	Ram (5740EP)	1			1/2" Nut	2
	RS50EPPR	Ram (5750EP)	1			Washer	2
10	RS40EPPG	Gauge (5740EP)	1			Short Cable (includes eye bolts)	1
	RS50EPPRG	Liquid Filled Gauge (5750EP)	1			Long Cable	1
				not shown	RS5740EPPLK	Product Label Kit	1
				not shown	RS5750EPPLK	Product Label Kit	1

Only items identified by part number are available separately.



**NOTES**

---

---

---

---

---

---

---

---

---

---

---

---

---

---

---

---

---

---

---

---

---

---

---

---

---

---

---

---

---

---

