

# STANLEY®

## TJ12 HYDRAULIC TRACK JACK (10 TON)



### USER'S MANUAL Safety, Operation and Maintenance



European Union  
Rue de la Loi/Wetstraat 175  
B-1048 Bruxelles/Brussel  
Belgique/België

© 2017 Stanley Black & Decker, Inc.  
New Britain, CT 06053  
U.S.A.  
72713 10/2017 Ver. 6

# DECLARATION OF CONFORMITY

DECLARATION OF CONFORMITY  
ÜBEREINSTIMMUNGS-ERKLÄRUNG  
DECLARATION DE CONFORMITE CEE  
DECLARACION DE CONFORMIDAD  
DICHIARAZIONE DI CONFORMITA

**STANLEY**  
Hydraulic Tools  
**CE**

I, the undersigned:  
Ich, der Unterzeichnende:  
Je soussigné:  
El abajo firmante:  
Io sottoscritto:

**Nuerenberg, David**

Surname and First names/Familiennname und Vornamen/Nom et prénom/Nombre y apellido/Cognome e nome

hereby declare that the equipment specified hereunder:  
bestätige hiermit, daß erklaren Produkt genannten Werk oder Gerät:  
déclare que l'équipement visé ci-dessous:  
Por la presente declaro que el equipo se especifica a continuación:  
Dichiaro che le apparecchiature specificate di seguito:

1. Category: **Track Jack**  
Kategorie:  
Catégorie:  
Categoria:  
Categoria:
2. Make/Marke/Marque/Marca/Marca **Stanley**
3. Type/Typ/Type/Tipo/Tipo: **TJ12**
4. Serial number of equipment:  
Seriennummer des Geräts:  
Numéro de série de l'équipement:  
Numero de serie del equipo:  
Matricola dell'attrezzatura:

**All**

Has been manufactured in conformity with  
Wurde hergestellt in Übereinstimmung mit  
Est fabriqué conformément  
Ha sido fabricado de acuerdo con  
E' stata costruita in conformità con

Directive/Standards Richtlinie/Standards Directives/Normes Directriz/Los Normas Direttiva/Norme	No. Nr Numéro No n.	Approved body Prüfung durch Organisme agréé Aprobado Collaudato
Machinery Directive EN ISO EN	2006/42/EC:2006 12100:2010 1494:2000+A1:2008	Self Self Self (Test Report Ref # 12142016TJ12) 2/14/2017 Ver-1)

5. Special Provisions: **None**  
Spezielle Bestimmungen:  
Dispositions particulières:  
Provisiones especiales:  
Disposizioni speciali:
6. Representative in the Union: **Patrick Vervier, Stanley Dubuis 17-19, rue Jules Berthonneau-BP 3406 41034 Blois Cedex, France.**  
Vertreter in der Union/Représentant dans l'union/Representante en la Union/Rappresentante presso l'Unione

Done at/Ort/Fait à/Dado en/Fatto a Stanley Hydraulic Tools, Milwaukie, Oregon USA Date/Datum/le/Fecha/Data

Signature/Unterschrift/Signature/Firma/Firma

Position/Position/Fonction/Cargo/Posizione North American Quality Manager

Test Report #12142016TJ12

# TABLE OF CONTENTS

SAFETY SYMBOLS .....	4
TOOL STICKERS AND TAGS .....	7
MAINTENANCE & CARE .....	8
OPERATING INSTRUCTIONS.....	11
TROUBLESHOOTING .....	13
SPECIFICATIONS .....	14
PUMP ASSEMBLY ILLUSTRATION & PARTS LIST .....	15
BASE ILLUSTRATION & PARTS LIST .....	16
SERVICE.....	17

## IMPORTANT

To fill out a product warranty validation form, and for information on your warranty, visit [www.stanleyinfrastructure.com](http://www.stanleyinfrastructure.com) and select the Company tab > Warranty.

**Note:** The warranty validation record must be submitted to validate the warranty.

**SERVICING:** This manual contains safety, operation and routine maintenance instructions. STANLEY Infrastructure recommends that servicing of hydraulic tools, other than routine maintenance, must be performed by an authorized and certified dealer. Please read the following warning.

## ⚠ WARNING

**SERIOUS INJURY OR DEATH COULD RESULT FROM THE IMPROPER REPAIR OR SERVICE OF THIS TOOL.**

**REPAIRS AND / OR SERVICE TO THIS TOOL MUST ONLY BE DONE BY AN AUTHORIZED AND CERTIFIED DEALER.**

For the nearest certified dealer, call STANLEY Infrastructure at (503) 659-5660 and ask for a Customer Service Representative.



# SAFETY PRECAUTIONS

Tool operators and maintenance personnel must always comply with and work in accordance with the safety precautions and instructions given in this manual and on the stickers and tags attached to the tool and hose.

These precautions are given for your safety. Review them carefully before operating the tool and performing general maintenance or repairs.

Supervising personnel should develop additional precautions relating to the specific work area and local safety regulations. Place the added precautions in the space provided.



- The TJ12 conforms with EN 1494:2000+A1:2008. This jack is intended for only the lifting of rail (railroad tracks) and should never be used for any other purpose other than what it was intended for or personal injury could result.
  - The user must be familiar with correct operation, maintenance and use of the jack. Lack of knowledge can lead to personal injury.
  - Operator must start in a work area without bystanders. The operator must be familiar with all prohibited work areas such as excessive slopes, dangerous terrain conditions and extreme climates.
  - Always wear safety equipment such as goggles, gloves, head protection and safety shoes at all times when operating the tool.
  - Warning: Hydraulic fluid under pressure could cause skin injection injury. If you are injured by hydraulic fluid, get medical attention immediately.
  - The total load lifted or supported by the jack must never exceed the rated capacity. Excess pressure can result in personal injury. Use a jack with sufficient capacity to lift a load. Keep clear of lifted loads.
  - Before each use, visually inspect the jack to prevent unsafe conditions from developing. Do not use jacks that are damaged, leaking, altered or in poor condition. See "INSPECTING THE TRACK JACK FOR DAMAGE OR LEAKAGE" on page 10
- Properly support the jack.
  - Do not put poorly balanced or off-center loads on the jack pad or jack. The load can tip and cause personal injury. Do not use in unstable or hazardous positions.
  - The jack must be used on flat surfaces to be able to carry the load correctly. The base must be completely supported. Do not push or lift on the ends of the base.
  - Do not lift people or loads with people on them.
  - As the load is lifted, use blocks or cribs to guard against a falling load.
  - To prevent personal injury, do not allow personnel to go under, or work under or on a load before it is properly secured by suitable means. All personnel must be clear of a load before lowering or lifting.
  - Lift only dead weight loads. Do not add additional weight to a lifted load.
  - Do not use jacks that are damaged, altered or in poor condition. Do not modify the jack in any way that would affect the compliance of the jack with standard BS EN 1494:2000+A1:2008.
  - The reservoir must have sufficient hydraulic fluid to fully stroke the jack. Use only approved hydraulic fluids. Also make sure that there is no contaminations of oil on the floor or working area
  - Read and understand the operating instructions in this manual, and the ASME B30.1 and EN 1494 safety code for jacks.
  - Users must ensure that all safety related decals and stickers are whole and readable. Replace those which become unreadable.
  - Never use extreme heat to disassemble a hydraulic ram or cylinder. Metal fatigue can lead to unsafe conditions.
  - Be aware of possible "pinch points" on the jack and stay clear to avoid personal injury.
  - When lifting with the edge of the lifting toe, place a wedge between the load and the top of the lifting

# SAFETY PRECAUTIONS

toe to avoid bending the cylinder column.

- Carry the jack by the carrying handle. Make sure the jack is in the fully lowered position before moving.
- End users must be trained in the proper use of the jack. Fully lower the jack when work is completed.
- Remove operating levers when not in use to avoid accidental dislocation of the jack, and reduce the tripping hazard.
- Make sure all personnel are clear of the load before lifting or lowering.
- DO NOT use extenders, spindles or accessories. Injury or death could result.
- Never use this tool when working around electrified rail, unless it is de-energized or you have been properly trained to work on electrified rail. If you are not sure the rail is live or not, you must treat it as being live and dangerous to life.
- The operator should always have the lifting device and load in view during movement.
- To avoid personal injury or equipment damage, all tool repair, maintenance and service must only be performed by authorized and properly trained personnel.
- Never use the tool in an explosive atmosphere. Sparks could ignite explosive gas.
- Never use the tool near strong magnetic fields.
- Do not handle loads, the nature of which could lead to dangerous situation (e.g. molten metal, acids, radiating material or especially brittle loads).
- When decommissioning the jack, drain all hydraulic fluid and dispose of the fluid in accordance with state and federal regulations.
- If the rated values are exceeded, use additional persons to aid in lowering.

# TOOL STICKERS AND TAGS

**NOTE:** The following information can be found on the bottom left side of the base. Model Number, Serial Number, 7250 PSI/500 Bar and year of manufacture are stamped in this location on each jack.

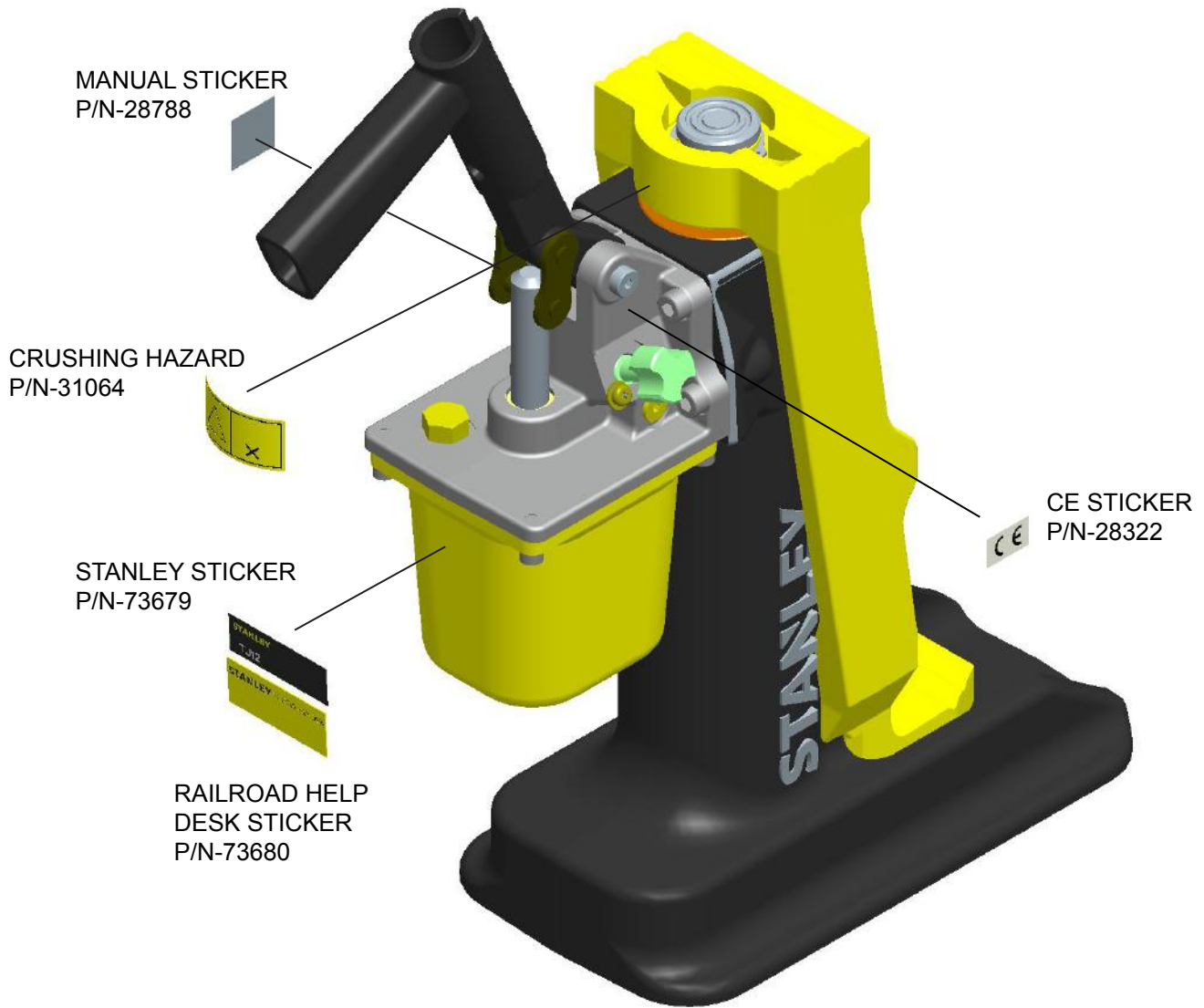

# MAINTENANCE & CARE

## GENERAL PROTECTION

- Store the Track Jack in an upright position, in a place where it is protected from the elements, abrasive dust and damage.
- Use only recommended repair and replacement parts and materials specified in the Parts List section of this manual.
- Do not use the jack for applications it was not designed for.
- Use the carrying handle to transport the Track Jack from location to location. Do not carry the Track Jack by inserting the jack handle in the socket.

## CLEANING

- Establish a routine to keep the jack as free from dirt as possible – daily, or at each shift change, for example.
- Jacks exposed to rain, sand or grit-laden air should be cleaned prior to each use.
- Exposed screw threads should be cleaned and re-lubricated as necessary.
- Keep the cylinder clean at all times. Keep the piston retracted when not in use.
- Operating lever and loadbearing surfaces should be free of slippery material or fluids.
- Keep tool labels and stickers legible.

## HYDRAULIC FLUID

The Track Jack holds approximately 28 ounces/820 cc cubic inches of hydraulic fluid (ISO#15) in its reservoir.

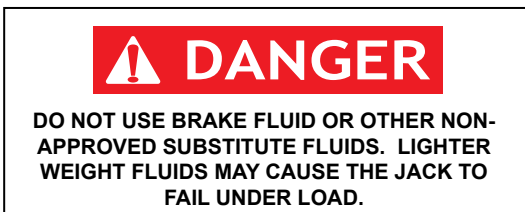

A jack that is low on hydraulic fluid will still be able to lift a full load, but not to the full lift height. As the reservoir

begins to run dry, the handle lever becomes very easy to pump and the jack stops lifting. This is a sign the jack is low on fluid.

To add oil:

1. Fully retract the plunger.
2. Make sure relief valve is closed.
3. Remove the fill plug (item # 3 on the Pump Assembly Illustration).
4. Fill the reservoir with new, clean fluid (use ISO#15 Hydraulic Fluid). Fill completely to the bottom of the threads on the fill plug hole.



## ANNUAL FLUID CHANGE

Track Jack hydraulic fluid should be changed every year to ensure proper operation of the jack.

To drain the fluid:

1. Thoroughly clean the area around the fill plug.
2. Remove the fill plug and lay the Track Jack on its back to allow the fluid to drain from the fill hole into an appropriate receptacle.
3. Dispose of the used hydraulic fluid in accordance with Environmental Protection Agency regulations.
4. Make sure dirt or other contaminants do not enter the reservoir while the fill plug is removed. When drained, check the fluid for contaminants. If the fluid appears gritty or dirty, flush the reservoir with clean hydraulic fluid before refilling.
5. Refill the reservoir with the recommended hydraulic fluid. Stand the jack upright, with the piston fully retracted. Fill the reservoir completely to the bottom of the threads on the fill plug hole.
6. Before returning the jack to service, fully extend the piston, without a load, by pumping the pump handle without the long extension handle. If the fluid level is correct, the pump handle will become almost impossible to pump by hand as the piston reaches full extension.
7. Replace the plug.
8. Inspect the jack for leaks, cracks, or other damage.



# MAINTENANCE & CARE

## DANGER

IMMEDIATELY TAKE OUT OF SERVICE ANY JACK THAT APPEARS TO BE DAMAGED OR LEAKING.

## PURGING AIR

Air trapped within the jack hydraulic system can be removed by performing the following steps:

1. Make sure the plunger is fully retracted.
2. Pry out the cap (see illustration at right).
3. Loosen (Do Not Remove) the capscrew under the cap located in the top of the plunger.
4. Place the jack in a suitable fixture to prevent the extension of the plunger while purging air.

## DANGER

THE FIXTURE USED TO PREVENT EXTENSION OF THE PLUNGER WHILE PURGING AIR MUST BE ABLE TO WITHSTAND THE FULL TEN TON FORCE OF THE JACK.

5. Add hydraulic fluid to the reservoir, if necessary.
6. Pump the handle until oil comes up through the thread area of the capscrew in the plunger.
7. Tighten the socket head capscrew to 10-12 ft. lbs./14-16 Nm. Then replace the cap.
8. Top off the reservoir with hydraulic fluid.

**Note: Make sure the plunger is fully retracted before filling the reservoir.**

When purging, remove cap and loosen. Do not remove the socket head capscrew that is under the cap.



## PRESSURE RELIEF SETTING

The pressure relief is pre-set at the factory and should never be altered. After the pressure relief is set at the factory the adjustment screw is made to not be tampered with.

If you have any issues with the relief setting, please contact STANLEY and ask for a Customer Service Representative.

## WARNING

THE PRESSURE RELIEF IS PRE-SET AT THE FACTORY, NEVER ATTEMPT TO ALTER IT'S SETTING. ALTERING THE RELIEF SETTING COULD RESULT IN DEATH, SERIOUS INJURY OR EQUIPMENT DAMAGE.

## WARNING

TO AVOID PERSONAL INJURY OR EQUIPMENT DAMAGE, ALL TOOL REPAIR, MAINTENANCE AND SERVICE MUST ONLY BE PERFORMED BY AUTHORIZED AND PROPERLY TRAINED PERSONNEL.

# MAINTENANCE & CARE

## INSPECTING THE TRACK JACK FOR DAMAGE OR LEAKAGE

1. Before each use, visually inspect the jack for leaks, cracks or other damage.

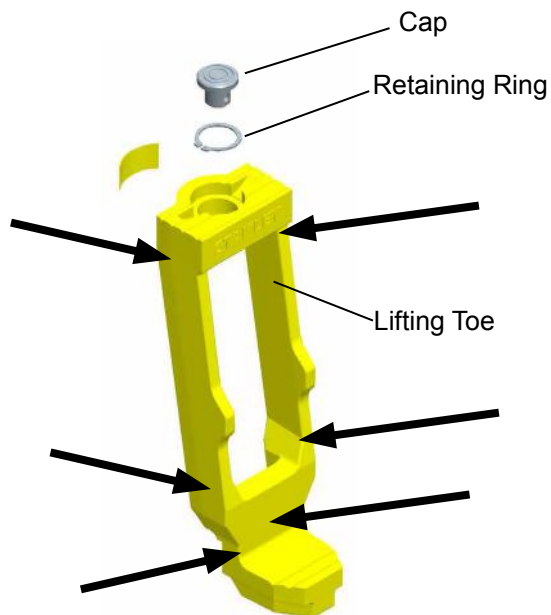

2. Once a month, remove the retaining ring and lifting toe. Thoroughly inspect the back, as well as the front and sides, for damage or cracks. Take special note of the areas indicated above.

# OPERATING INSTRUCTIONS

## DANGER

MAKE SURE THAT ALL PERSONNEL ARE CLEAR OF THE LOAD BEFORE ATTEMPTING TO RAISE OR LOWER THE JACK. SERIOUS INJURY OR DEATH COULD RESULT FROM THE IMPROPER USE OF THIS TOOL.

## DANGER

MAKE CERTAIN THAT THE LIFTING TOE IS FULLY ENGAGED ON THE LOAD, AND THE ENTIRE JACK IS STABLE, BEFORE PROCEEDING FURTHER.

## PREPARATION PROCEDURES

Before putting a new Track Jack into service, or after an extended period of being unused, perform a visual inspection for bent, broken, cracked, missing or worn components. (see "INSPECTING THE TRACK JACK FOR DAMAGE OR LEAKAGE" on page 10.

Ensure the hydraulic fluid and lubricant level is correct. Fully extend and retract the jack without a load to ensure that the jack is primed and operating properly.

## RAISING A LOAD

1. Before using the Track Jack, make sure that it is set on a firm surface capable of bearing the intended load.
2. Make sure the Spindle (item 41) is closed, by turning it clockwise until it is hand-tight.

## DANGER

OVERTIGHTENING THE SPINDLE (ITEM 41) CAN DAMAGE THE VALVE SEAT. DO NOT USE PLIERS OR WRENCHES TO TIGHTEN.

3. Pump the handle by hand until the toe lift or head lift plate rises and engages the load.

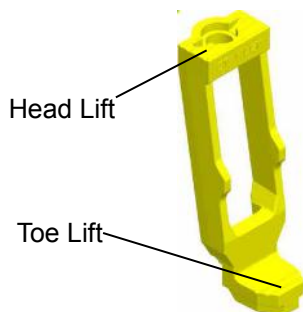

4. Insert the jack handle fully into the handle socket. Pump until the desired lift has been obtained.

## WARNING

USE ONLY THE RECOMMENDED LENGTH JACK HANDLE. DO NOT USE LONGER HANDLES. SEE "SPECIFICATIONS" ON PAGE 14.

5. Remove the jack handle from the handle socket.
6. Crib or block the load to prevent accidental dropping of the load.

## LOWERING A LOAD

1. Make sure all personnel are clear of the load.
2. Remove cribbing or blocking, if used.
3. Slowly open the spindle (item 41) by turning it counterclockwise.

## DANGER

LOWERING SPEED IS CONTROLLED BY OPENING THE SPINDLE MORE OR LESS. OPEN SLOWLY TO CONTROL THE LOWERING SPEED. CAUTION: OPENING THE SPINDLE TOO MUCH WILL CAUSE THE LOAD TO DROP QUICKLY.

4. When the load reaches the desired level, close the spindle by turning it clockwise until it is hand tight.

## HORIZONTAL OPERATION

The Track Jack can also be used horizontally to separate two items, as long as it is placed with the handle socket facing upwards.

1. Place the Track Jack base against the largest, heaviest or otherwise least moveable of the two items.
2. Close the spindle (item 41) by turning it clockwise until hand tight.
3. Pump the handle socket by hand until the lifting toe or the head of the lifting toe firmly engages the

# OPERATING INSTRUCTIONS

more moveable of the two items.

4. Make sure personnel are clear of all items being jacked before attempting to move anything.
5. Insert the jack handle into the handle socket. Pump until the desired separation has been obtained.
6. Remove the jack handle from the socket.
7. To free the jack, open the spindle by turning it counterclockwise. When the lift plate is clear, close the spindle.
8. The operator must watch the lifting device and the load during all movements.

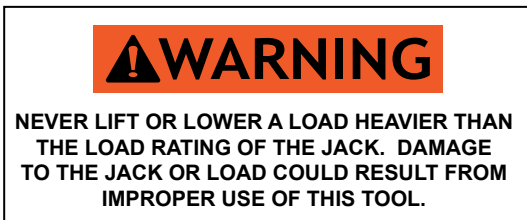

## PUMPING HANDLE

A pumping handle is included with the Track Jack. DO NOT use the pumping handle for any other purpose. DO NOT substitute other material for use as a pumping handle or use a longer handle than what is specified on "SPECIFICATIONS" on page 14

# TROUBLESHOOTING

If symptoms of poor performance develop, the following chart can be used as a guide to correct the problem. Because the Track Jack can be used for many different applications, this information is general in nature and does not address specific uses.

PROBLEM	CAUSE	CORRECTION
Jack will not raise	A) Release valve not closed	Close the valve
	B) Release valve ball not seating properly	Have jack serviced by a qualified technician
	C) Seal failure	Have jack serviced by a qualified technician
Jack raises but will not hold	A) Release valve ball not seating properly	Have jack serviced by a qualified technician
	B) Relief valve set too low or malfunctioning	
	C) Seal failure	Have jack serviced by a qualified technician
Jack only raises part way	Hydraulic fluid level is low	Add hydraulic fluid (See "SPECIFICATIONS" on page 14)
Jack leaks hydraulic fluid	Seal failure	Have jack serviced by a qualified technician
Jack retracts slowly	Air in the hydraulic system	Purge air from the hydraulic system
Jack raises, but pulses and hesitates	Air in the hydraulic system	Purge air from the hydraulic system

# SPECIFICATIONS

## PERFORMANCE

Maximum Lift .....	8.8 in. / 22.3 cm
Maximum Load .....	10 tons / 9,072 kg
Pump Displacement .....	46 cu. in. / 7.5 cc stroke, single speed
Advance rate per stroke .....	0.160 in. / 4.0 mm
Pressure at rated load .....	7250 psi / 500 bar Model TJ12
Maximum pump handle effort .....	75 lbs. / 34 kg

## DIMENSIONS

Baseplate Size TJ12111S .....	6.000 x 11 in. / 15 x 28 cm
Baseplate Size TJ12112S Narrow .....	4.500 x 11 in. / 11.4 x 28 cm

Weight ..... 45 lbs / 19.5 kg

Lift Toe Width and Depth ..... 2-1/2 in x 3 in. / 63 mm x 76 mm  
Height (Retracted) ..... 14.7 in. / 37.3 cm

Height (Extended) ..... 23.500 in. / 597 mm  
Net Weight (with oil) no handle ..... 45 lb / 20.4 kg

Pump Handle Length (p/n-52813) ..... 36 in. / 91 cm

## HYDRAULIC REQUIREMENTS

Reservoir Capacity ..... 28 oz / 828 cc  
Recommended Fluid ..... ISO #15 Hydraulic Fluid.

Standards ..... ASME B30.1, EN 1494:2009

**Note: This product does not exceed 70 dBA per ISO 11201**

**Note: Weights, dimensions and operating specifications listed on this sheet are subject to change without notice. Where specifications are critical to your application, please consult the factory.**

## REPAIR KITS

**Note: For items in repair kits see both illustrations and parts lists.**

Cylinder Repair Kit..... 56522  
Includes Items: 1, 7, 19, 21, & 27 thru 31.

Reservoir Repair Kit ..... 56524  
Includes Items: 25, 26 and 35

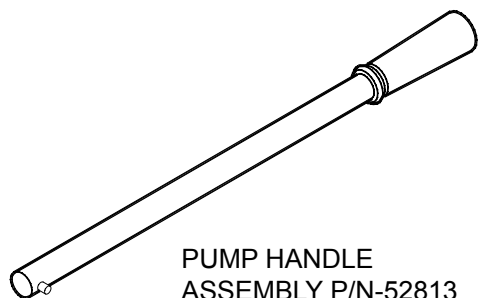

# PUMP ASSEMBLY ILLUSTRATION & PARTS LIST

For Cylinder Repair Kit & Reservoir  
Repair kit see page 13.

ITEM	PART #	QTY	DESCRIPTION
1	00055	2	O-RING *
2	01671	1	-6 HEX HD SAE PLUG
3	04855	1	RETAINING RING EXTERNAL
5	05291	1	STEEL BALL 7/32
6	07327	1	O-RING *
7	15398	2	BACK-UP RING *
8	21338	1	STEEL BALL 5/32
9	26005	1	# 80 MASTER LINK
10	26039	1	O-RING *
11	28323	1	STICKER "CE" 12MM
12	28788	1	STICKER - MANUAL
25	52831	1	BLADDER
26	52832	1	RESERVOIR
33	56517	1	ROD WIPER *
34	56518	4	CAPSCREW
35	56521	4	CAPSCREW
36	71431	1	COMPRESSION COIL SPRING
37	71478	1	OIL TUBE
38	74863	1	PUMP BODY (INCLUDES EXPANDER PLUGS)
38A	74864	1	PUMP ASSY (INCLUDES ITEMS 1-64 & 16)
39	71707	1	O-RING *
40	72663	1	CHECK VALVE SEAT ASSY (INCLUDES ITEM 6)
41	71715	1	SPINDLE
42	71716	1	PISTON
43	76751	1	RELIEF VALVE SEAT-COINED
44	71738	1	SELF LOCKING SETSCREW
46	72664	1	CHECK VALVE HOUSING ASSY (INCLUDES ITEM 60)
48	73679	1	NAME TAG - TJ12
49	73680	1	RR HELP DESK STICKER
51	76494	1	BACK-UP RING *
53	76697	1	HANDLE (INCLUDES DU BUSHINGS)
56	76716	1	GROOVED CLEVIS PIN
57	76717	1	SCREW
58	76718	1	SPRING SEAT
60	76773	1	O-RING *
61	76817	1	RELIEF VALVE ASSEMBLY (RELIEF IS PRE SET AT FACTORY)
62	79297	1	ORIFICE, TJ12 DESCENT
63	79301	1	SHIELD, ORIFICE
64	350023	2	HOLLOW HEX PLUG -3 SAE

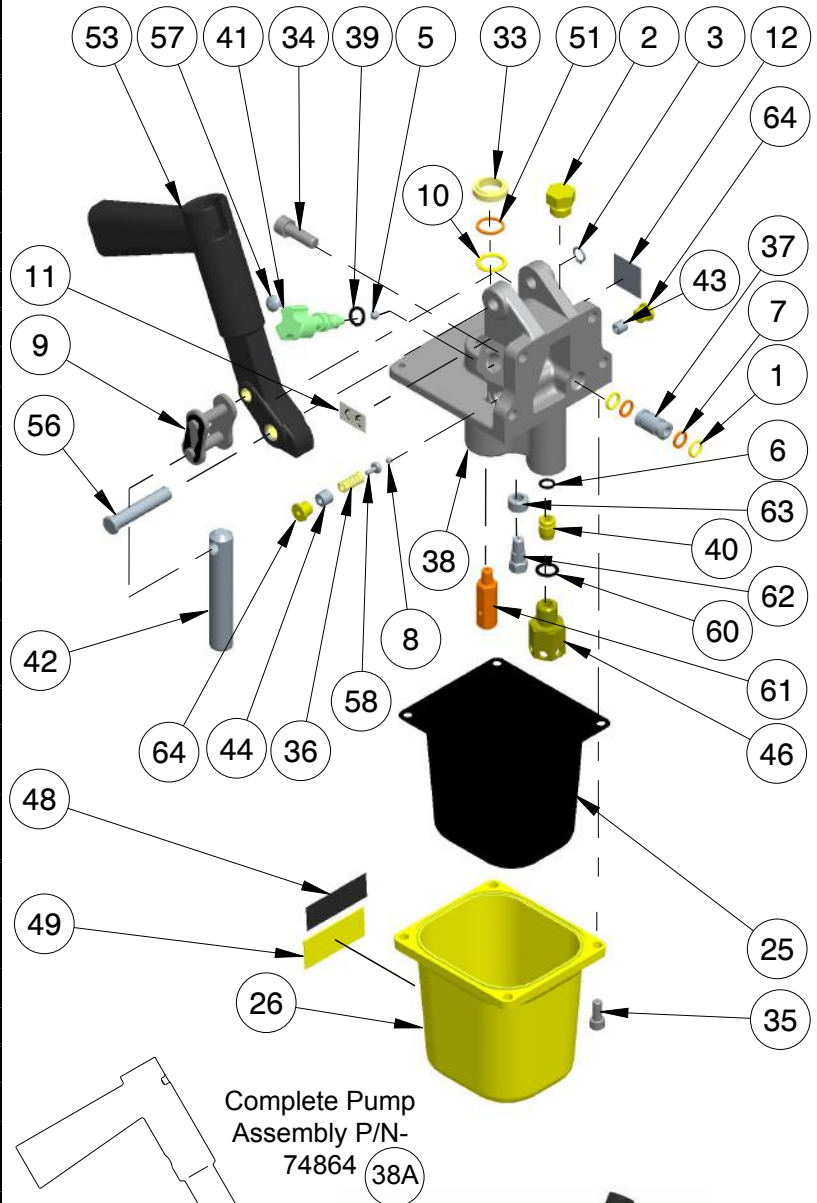

Complete Pump Assembly P/N-74864 (38A)

\* DENOTES PART IN SEAL KIT (P/N-72735) (see both parts list for items included in seal kit)

Model #, Serial # Located here.



TJ12111S  
TJ12112S Narrow Base

# BASE ILLUSTRATION & PARTS LIST

For Cylinder Repair Kit & Reservoir Repair kit see "Repair Kits" on page 14.

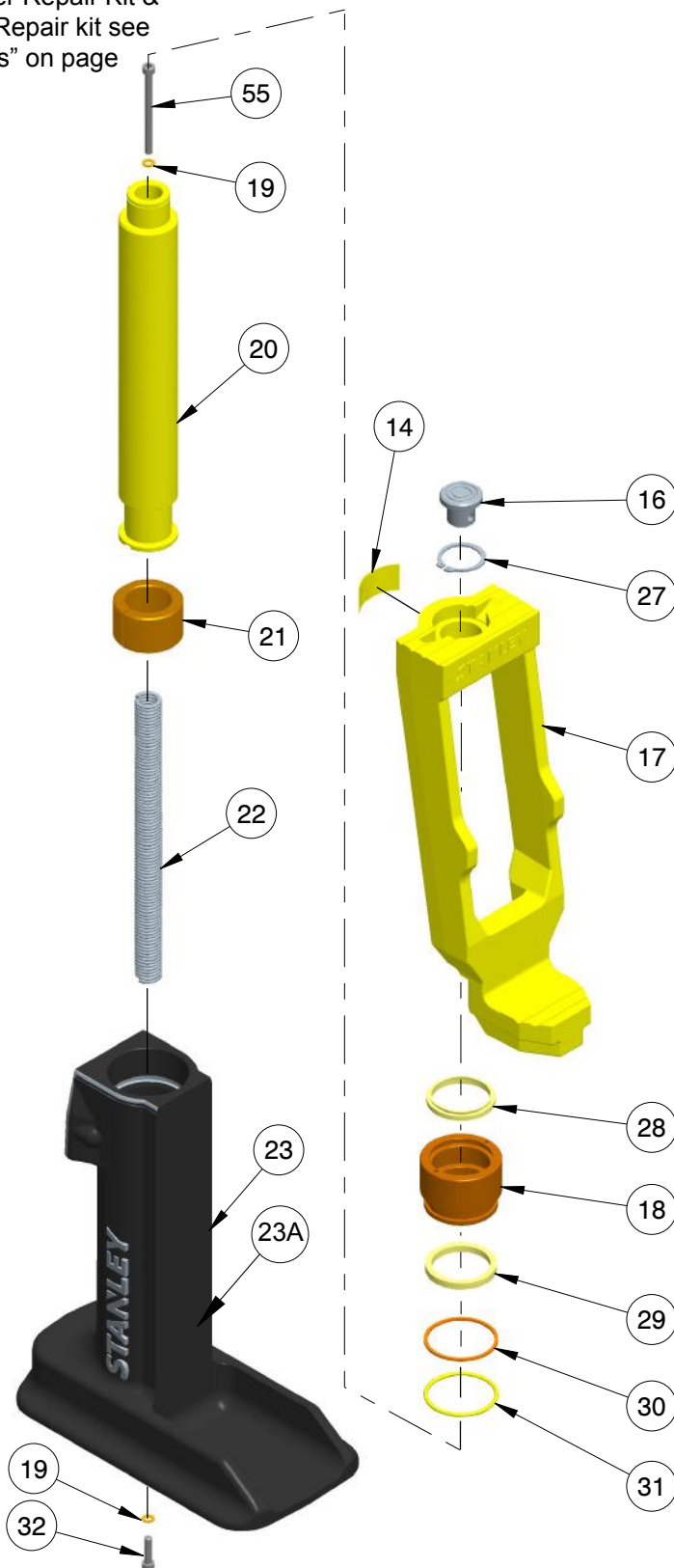

ITEM	PART #	QTY	DESCRIPTION
14	31064	1	CRUSHING HAZARD DECAL
16	52805	1	CAP ASSY.
17	52806	1	LIFTING TOE
18	52807	1	STOP RING
19	52808	2	GASKET *
20	52809	1	PLUNGER
21	52810	1	BEARING
22	52811	1	SPRING ASSEMBLY
23	52812	1	BASE TJ12
23A	56601	1	BASE (TJ12112S)
27	56506	1	RETAINING RING *
28	56507	1	ROD WIPER *
29	56508	1	ROD SEAL *
30	56509	1	BACK-UP RING *
31	56510	1	O-RING *
32	56512	1	HSHCS M6-1.0 X 25
55	76714	1	HSHCS M6-1.0 X 80

\* DENOTES PART IN SEAL KIT P/N-72735 (see both parts list for items included in seal kit)











# **STANLEY®**

Stanley Infrastructure  
3810 SE Naef Road  
Milwaukie, Oregon 97267-5698 USA  
(503) 659-5660 / Fax (503) 652-1780  
[www.stanleyinfrastructure.com](http://www.stanleyinfrastructure.com)  
European Union  
Rue de la Loi/Wetstraat 175  
B-1048 Bruxelles/Brussel  
Belgique/België