

PORTABLE HYDRAULIC JACK

20 TON CAPACITY

Models 91-233
93233, YA233
Series "S"

SPECIFICATIONS

Height (Closed)	Power Raise	Height (Max)	Handle Length
10-7/8"	7-5/8"	18-1/2"	20-1/2"

MODEL	LABEL KIT NO.	REPAIR KIT NO.
91-233	236669	91-415
93233	236671	236681
YA233	236673	236681

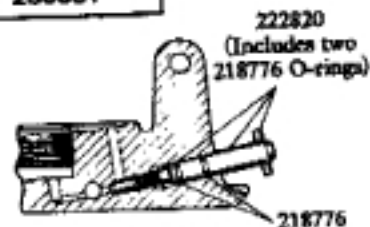
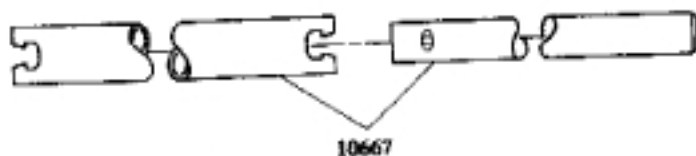

SECTION C-C

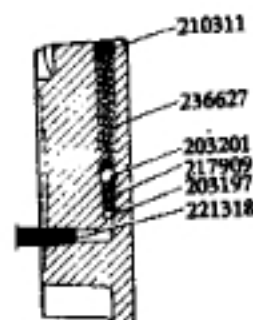
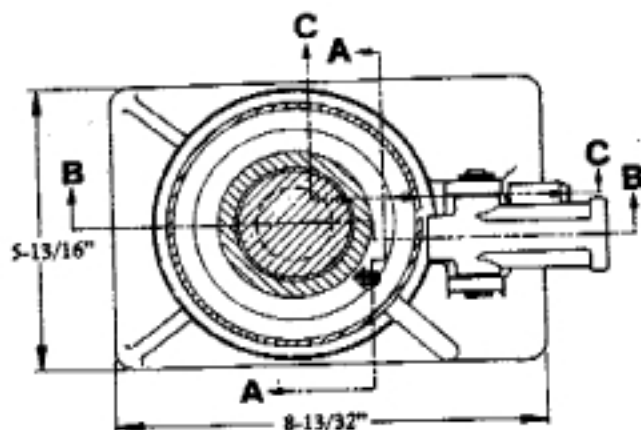

SECTION A-A

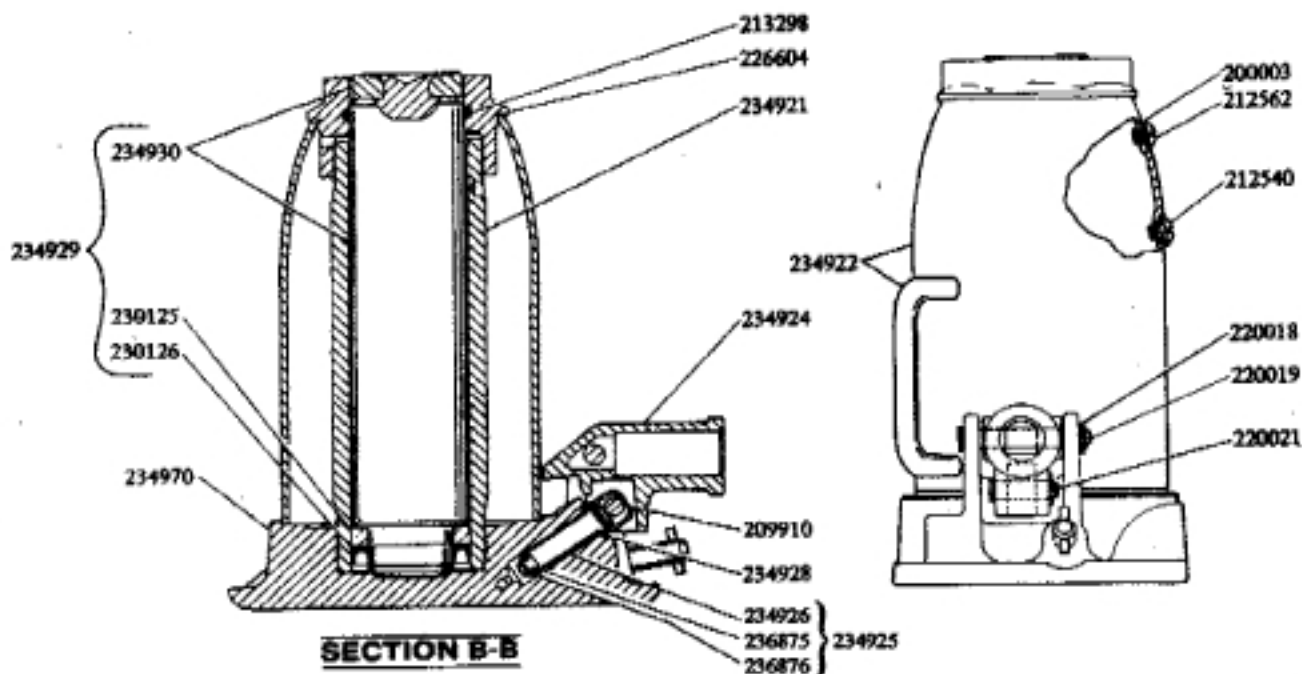

SECTION B-B

LINCOLN

A PENTAIR COMPANY

One Lincoln Way
St. Louis, MO 63120-1578
Customer Service, (314) 679-4300

SECTION - **W2**
PAGE - **4E**

TROUBLESHOOTING

PROBLEM	SOLUTION
1) Will not lift full height. 2) Will not lower completely.	Reservoir could be overfilled - With jack upright, remove filler screw, open release and SLOWLY push jack ram into lowered position. Any excess oil will run out fill hole. Replace filler screw when oil has stopped flowing.
1) Will not lift load. 2) Will not lift full height. 3) Pump feels "spongy" under load.	The jack could be low on oil - With jack in upright position and ram fully lowered, remove filler screw and fill reservoir with clean Hydraulic Jack Oil - correct oil level is reached when oil level is at bottom edge of fill hole. The jack could be air bound - Open the release valve one full turn and pump the handle vigorously. Close the release valve and pump to full height. Continue pumping several times at full height. Open release valve and push ram down into lowered position. Close release valve and operate normally.
1) Will not lift load. 2) Handle raises under load. 3) Handle lowers under load.	Valve might not be closing - With release valve closed and ram in fully lowered position, SLOWLY raise ram to full height. Open release valve and push ram down into lowered position. Jack should now operate properly.
In cold ambient conditions; 1) Will not lift load. 2) Pump feels "spongy" under load.	The jack might not be vented - Jack must be vented in cold ambient conditions. With vent screw open approximately two turns, open the release valve one full turn and pump the handle vigorously. Close the release valve and pump to full height. Continue pumping several times at full height. Open release valve and push ram down into lowered position. Close release valve and operate normally.
1) Will not work in horizontal position.	Jack in wrong position for horizontal operation - Valving plug on side of jack base must face upward. The jack could be low on oil - With jack in upright position and ram fully lowered, remove filler screw and fill reservoir with clean Hydraulic Jack Oil - correct oil level is reached when oil level is at bottom edge of fill hole.

If the above procedures do not correct the problem, contact your nearest Authorized Warranty and Service Center. When submitting any jack or equipment to be repaired, be sure to state the nature of the problem and indicate whether an estimate of the repair cost is needed.

IMPORTANT: As with any hydraulic unit, this unit may occasionally become "air bound" due to being tipped over during shipment. To purge the air from the oil lines, open the release and pump rapidly a few strokes. Close release and pump to full height, then open the release to allow the ram to descend rapidly. If the pump still seems "spongy", repeat the procedure.

SERVICE PARTS

PART	QUAN.	DESCRIPTION	PART	QUAN.	DESCRIPTION
10667	1	Handle	222820	1	Release stem ass'y.
*200003	2	Gasket	226604	1	Tank nut
*203197	1	Ball	*230125	1	Heel plate
*203201	1	Ball	234921	1	Cylinder
209910	1	Pump clip	234922	1	Oil tank & handle ass'y.
*210311	1	Pipe plug	234924	1	Handle socket
212540	1	Filler screw	234925	1	Pump ass'y.
212562	1	Vent screw	234926	1	Pump piston
*213298	1	O-ring	*234927	1	U-cup packing
*217909	2	Spring	*234928	1	Wiper
*218776	2	O-ring	234929	1	Ram ass'y.
220018	1	Retaining ring	234930	1	Ram & cup ass'y.
220019	1	Fulcrum pin	234970	1	Base
220021	1	Pump pin	*236627	1	Spring
*221318	1	Suction screen	236875	1	Back up ring
			*236876	1	U-cup packing

*Included in 226681 and 91-415 Repair Kit.

RETAIN THIS INFORMATION FOR FUTURE REFERENCE

When ordering replacement parts, list: Part Number, Description, Model Number, and Series Letter.

LINCOLN provides a Distributor Network that stocks equipment and replacement parts.

A list of Authorized Service Departments will be furnished upon request.