

TEMPLETON, KENLY & CO., INC.

2525 Gardner Road, Broadview, Illinois 60153 (312) 865-1500

HAND PUMP REPAIR PARTS SHEET OPERATING INSTRUCTIONS

ESJP 300-4
ESJP 460-4

NOTE: Be sure to read these instructions completely before operating this pump. Failure to follow these instructions may result in personal injury or damage to the pump. Safety and Operating instructions are on the back page.

1. INTRODUCTION

Dirt - This will quickly ruin any hydraulic system. Before hooking up a system, insure that couplings are clean and free of foreign matter. Dirt, sand, etc. can cause difficult assembly and premature wear to seals and steel components of your hydraulic equipment. After each use of the system, clean all couplings and assemble all dust caps.

Air Bleeding - Air in a hydraulic system can be hazardous because it is compressible. Before loading any cylinder, air must be bled from the system.

With double-acting cylinders, the cylinder may be purged by fully extending and retracting the unloaded piston several times. (It is not necessary to invert the cylinder.)

Air in the system can cause sluggish or hesitant action of the piston when extending or retracting. When air has been purged, cylinder action will be smooth and uniform.

Air can enter your system in many ways, but the most common is by inadequate useable reservoir capacity. (Oil level drops below inlet and pump sucks air.)

2. ASSEMBLY

- Remove two No. 87145 plugs from the 3/8" NPT ports A & B located on both sides of the directional control valve. (See figure 1).
- Assemble hoses or quick-disconnect couplings at these ports.

Figure 1 - Dimensions for ESJP 300-4

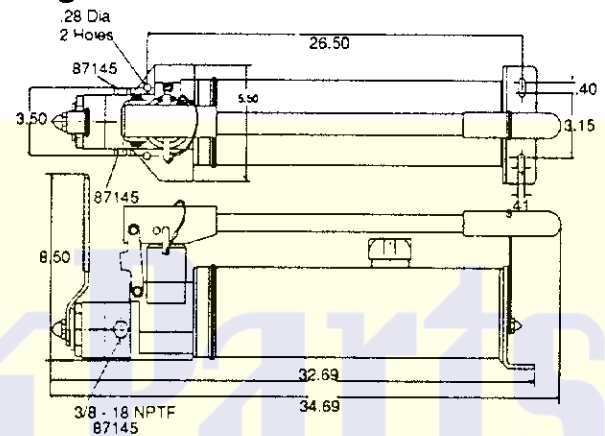

- Connect hoses to cylinder or ram.
- All Simplex cylinders are equipped with quick-disconnect couplings. These couplings make assembly of your system simple and quick. These couplings must be assembled by hand. If wrenches or pliers seem to be necessary for assembly, you are doing something wrong. If couplings will not fully engage (See figure 2 for proper engagement), shift the directional control valve a few times to release any pressure that may have built up.

Figure 2

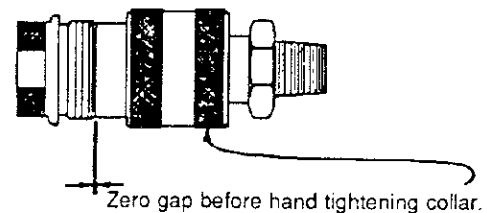

- The reservoir fill cap is vented so there is no need to open any air vents prior to using the pump.



ESJP 300-4 & ESJP 460-4

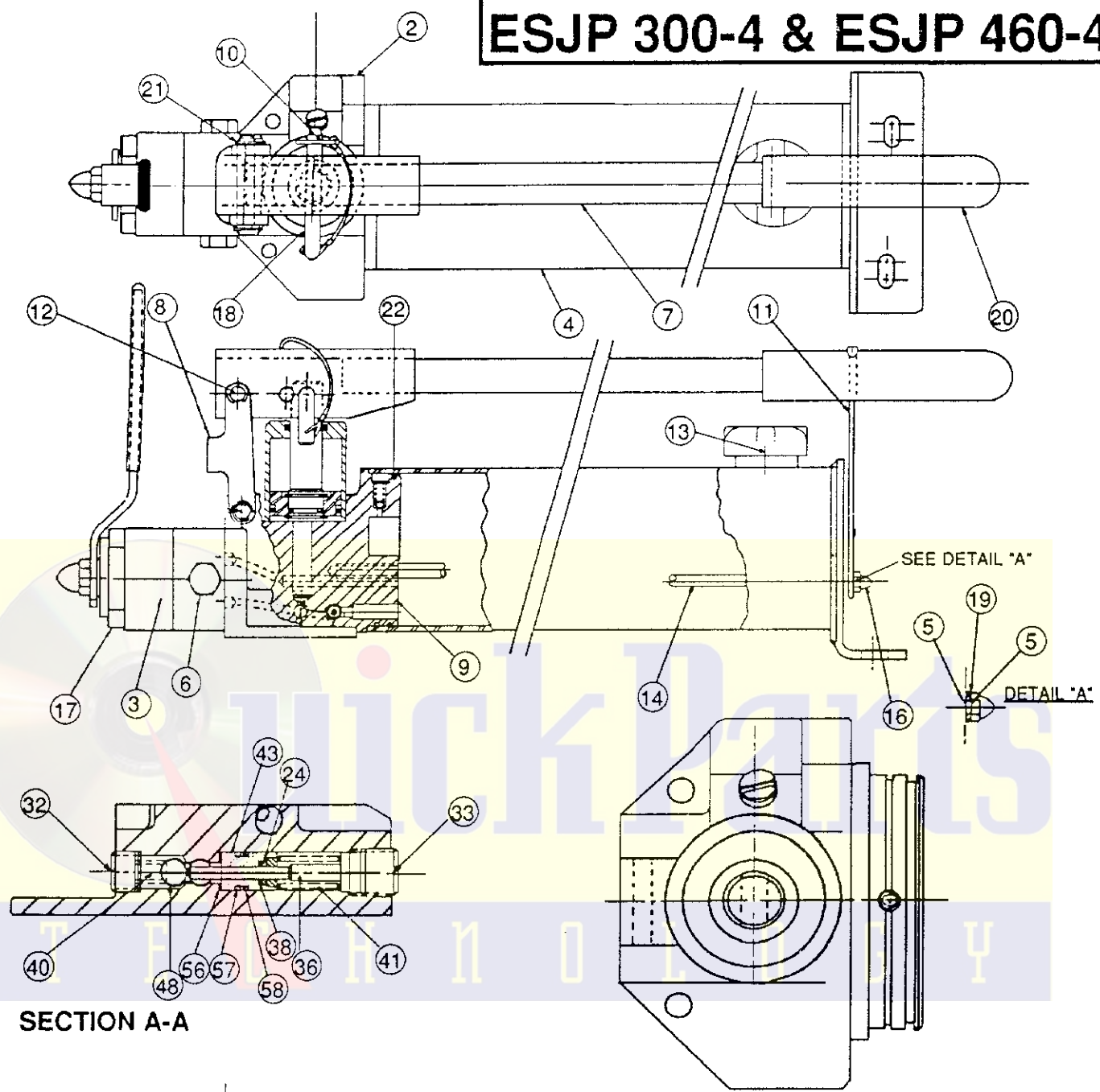

SECTION A-A

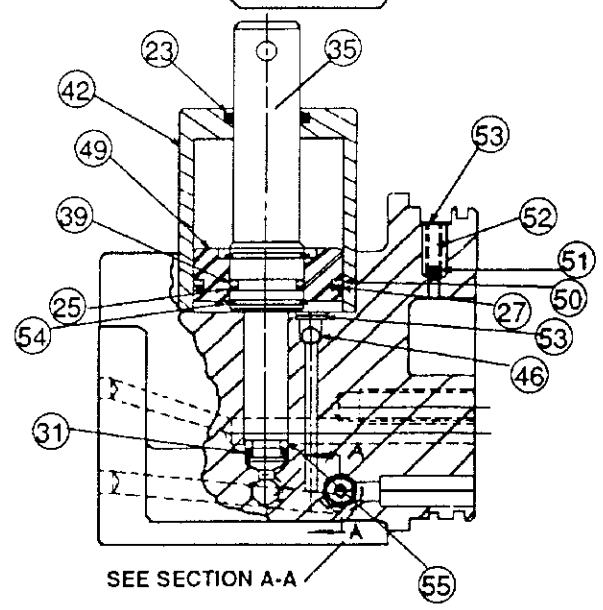
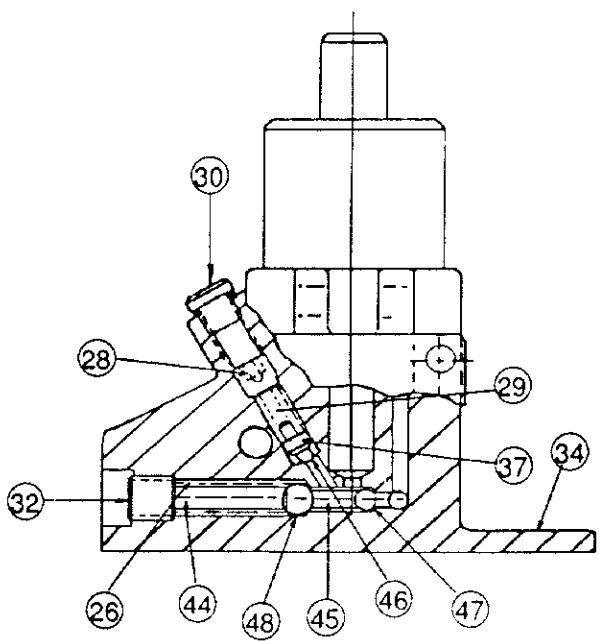

SEE SECTION A-A

ITEM	DESCRIPTION	CONTROL NUMBERS		QUANTITY
		ESJP 300-4	ESJP 460-4	
1	Hydraulic Oil	18139	18139	
2	Pump Body ASM	35106	35106	1
3	4 Way Valve	35107	35107	1
4	Reservoir	35110	35117	1
5	Gasket	85726	85726	2
6	Hex Pipe Plug	87145	87145	2
7	Handle Weld	88477	88985	1
8	Pump Link	88478	88478	1
9	Intake Screen	88481	88481	1
10	Hair Cotter Pin	88483	88483	1
11	Handle Latch	88484	88484	1
12	Pin	88486	88486	2
13	Filler Cap	88487	88487	1
14	Tie Rod	88509	88983	1
15	Decal (Not Shown)	88510	88987	1
16	Acorn Nut	88511	88511	1
17	SHCS 3/8 - 16	88521	88521	4
18	Lock Pin	88530	88530	1
19	Spacer Latch	88622	88622	1
20	Handle Grip	95039	95039	1
21	Pin Clip	92540	92540	4
22	O-Ring	5602238	5602238	1
23	Wiper	5601346	5601346	1
24	O-Ring	5602008	5602008	1
25	O-Ring	5602115	5602115	1
26	Spring	88501	88501	1
27	O-Ring	5602128	5602128	1
28	Adjusting Screw	66083	66083	1
29	Rel. Valve Spring	66085	66085	1
30	Plug SAE #4 With O-Ring	68258	68258	1
31	O-Ring	56020125	56020125	1
32	Pipe Plug	82552	82552	2
33	Pressure Plug	84084	84084	1
34	Pump Body	88490	88490	1
35	Piston Pump	88491	88491	1
36	Piston Unloading	88493	88493	1
37	Spring Cap	88497	88497	1
38	Back-Up Washer	88498	88498	1
39	Back-Up Washer	88499	88499	1
40	Compression Sp.	88500	88500	1
41	Compression Sp.	88529	88529	1
42	Piston Cylinder	88525	88525	1
43	Cartridge Assembly	89061	89061	1
44	Spacer Out. Ball	88717	88717	1
45	Spacer In. Ball	88718	88718	1
46	Ball 3/16	90548	90548	2
47	Ball Bearing	92549	92549	1
48	Ball Bearing	92550	92550	2
49	Piston Gland	88526	88526	1
50	Back-Up Washer	88527	88527	1
51	3/16" Rubber Ball	88827	88827	1
52	Spring	88828	88828	1
53	Retaining Ring	88835	88835	2
54	Retaining Ring	88528	88528	2
55	Back-Up Washer	88612	88612	1
56	Shim	89063	89063	2
57	B-Up Ring	5608012	5608012	1
58	O-Ring	5602012	5602012	1
59	Packing Kit	54385	54385	1

SAFETY

A. WORKING PRESSURE

The pump's maximum working pressure is 10,000 PSI (700 kg/cm²). Make sure that all hydraulic equipment such as rams, hoses, etc. used with this pump are rated at 10,000 PSI operating pressure.

B. HYDRAULIC CONNECTIONS

Never disconnect or connect any hydraulic hoses or fittings without first unloading the ram, then shift, or open all hydraulic controls several times to assure that the system has been depressurized. If the system includes a gauge, double check the gauge to assure pressure has been released. When making connections with quick-disconnect couplings, make sure the couplings are fully engaged. Threaded connections such as fittings, gauges, etc. must be securely tightened and leak free.

DO NOT over-tighten connections. Connections need only be secure and leak free. Over-tightening can cause premature thread failure.

CAUTION: Loose or cross threaded fittings can be potentially dangerous if pressurized. Never hold or stand directly in line with any hydraulic connections while pressurizing. Never grab, touch or in any way come in contact with a hydraulic pressure leak. Escaping oil can penetrate the skin and a serious injury can result.

C. JACKING SAFELY

You should know the weight of what you intend to lift and choose a ram with at least 10% more capacity. The ram must be placed on a solid foundation so that the base of the ram is fully supported. The load must be centered on the ram, or equally distributed on multiple rams. Off-center loading can result in the ram slipping out and loss of the load. Never crawl or place any part of your body under any load at any time. Insert blocking or cribbing under the load as you lift. Hydraulic rams are meant for lifting only and should not be used to support the load for any period of time. You should obtain and be familiar with the American National Standards Institute rules that apply to hydraulic rams and jacks (ANSI B30.1).

D. HOSES

DO NOT DROP HEAVY OBJECTS ON HOSE. A sharp impact may kink wire strands on which the strength of the hose depends.

AVOID SHARP KINKS IN HOSE. Never apply pressure when hose is swung in sharp curves or when the hose is visibly kinked.

KEEP AWAY FROM FIRE AND HEAT. Keep your equipment away from excessive heat which tends to soften packings and cause leakage. Heat also weakens the structure of hose and packings. For best performance, DO NOT expose equipment to temperatures above 160° F.

OPERATING INSTRUCTIONS

- A. Keep the control valve handle in neutral position. Operate pump handle several times to remove air from the system and to prime the pump. Pushing directional control valve lever to the right directs pump output to right-hand port. Pushing lever to the left directs pump output to the left-hand port. Center position is neutral/hold. Pump output is directed back to tank.
- B. You may operate a single-acting cylinder with this style pump by merely connecting one hose to the single-acting cylinder. Move the valve lever to the side that is connected to the cylinder in order to advance, move the lever to the center in order to hold, and to the opposite of the advance position in order to retract.
- C. Be sure the pump reservoir is full of hydraulic oil. **NEVER FILL THE RESERVOIR UNLESS THE CONNECTED RAMS ARE FULLY RETRACTED.**

MAINTAINANCE

Completely change oil at least twice a year. The following conditions require more frequent oil changes:

- a. Rigorous duty, where oil may leak out or become contaminated.
- b. High humidity environment and extreme changes in temperature that can result in condensation inside the reservoir.
- c. Dirty or dusty environments that may contaminate the oil.

Flushing the pump. If you suspect your pump has been contaminated or discover sludge or other deposits on internal components, you should thoroughly flush the pump.

- a. Remove the old oil from the reservoir, then thoroughly clean the reservoir and refill with a clean, nonflammable flushing oil.
- b. Reassemble the pump head to the reservoir and pump the pump handle approximately 50 times with the valve in neutral.
- c. Empty the reservoir and refill with clean Simplex oil.