



PA SERIES FOOT PUMP

OPERATIONAL & REPAIR PART SHEET

PART SHEET # 54187
REV. C
09/07

MODELS:

- PA91
- PA91-1
- PA95
- PA95-1

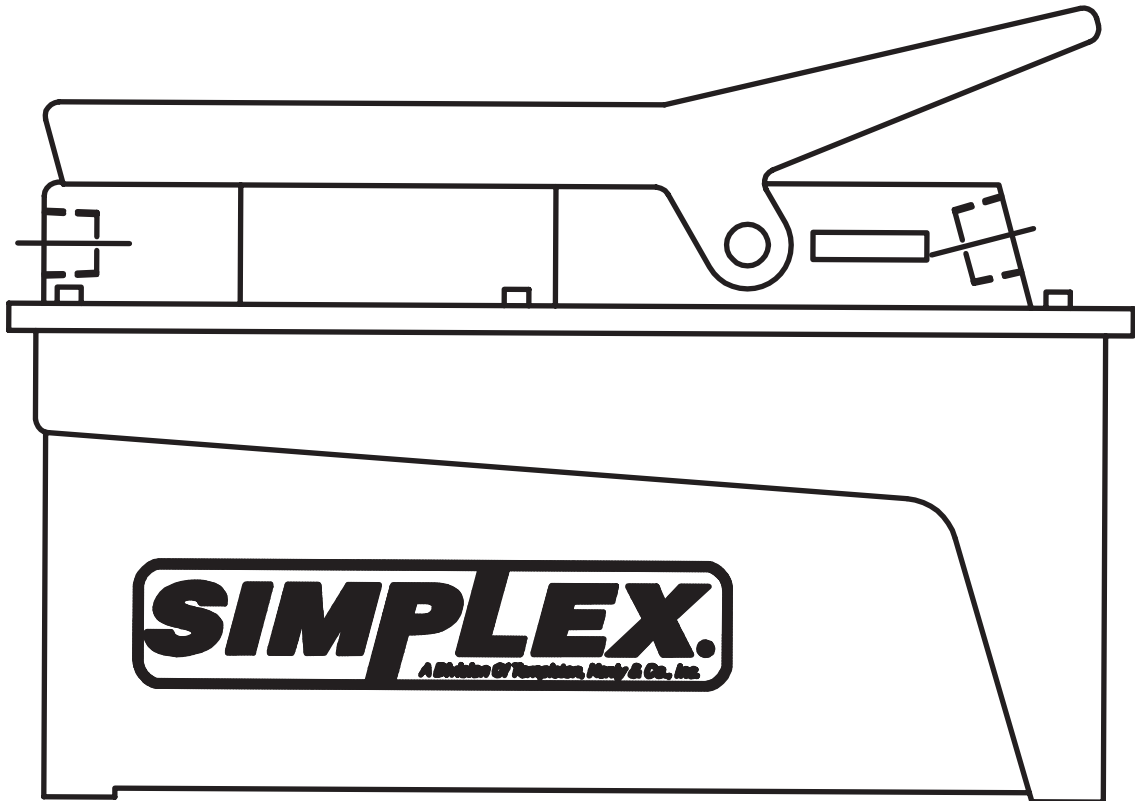

BEFORE USE

1. Locate and remove the VENT / OIL FILLER PLUG (item #32). Ensure the oil level is just below the oil filler plug hole. Re-install the oil filler plug.
2. Remove shipping plugs (items 21 & 51) and discard. Pour a teaspoon of good quality, air tool #10 wt. non-detergent oil into the air inlet in port where item # 21 was located).
3. Install the appropriate air supply coupler (item #21) and a 3/8" NPT hydraulic connection (item #51).

OPERATION

1. Make sure the pump is on a level surface.
2. Once the connections are made, operate the pump for three second to evenly distribute the air lubricating oil.
3. Check for leaks in system and repair as needed. Before repairs are made, disconnect air source and application, then depressurize reservoir. Do so simply by pressing the pedal for three seconds.
4. Operate pump until desired position is reached.
5. To retract application, simply press down on the RELEASE valve portion of the pedal pump. Fully depressing pedal will LOCK the DETENT feature to "on".

MAINTENANCE

1. Inspect hose and connections daily. Replace damaged components immediately with Simplex Authorized replacement parts only.
2. Tighten connections as needed. Use pipe thread Teflon when servicing connections. NOTE: DO NOT OVER TIGHTEN CONNECTIONS.
3. When not in use or during storage:
 - ✓ Disconnect pump from air source, depressurize and disconnect hydraulic hoses from application.
 - ✓ Wipe clean, throughout.
 - ✓ Shelter the pump with protective cover.
 - ✓ Store in clean, dry environment.
 - ✓ Avoid temperature extremes.

HOW TO FILL THE RESERVOIR

Disconnect hydraulic hose from application, remove air source from pump.

1. With reservoir horizontal, remove the vent / oil filler plug.
2. Use a small funnel to fill reservoir to within 1/2 inch of the opening.
3. Use Simplex oil only (Model # AO1, 1 gallon). Using oil other than Simplex Brand voids the pump warranty.
4. Wipe up any spilled fluid and install oil filler screw.
5. Return pump to original position (parallel to a flat level surface), reconnect application and air source. Operate for a few seconds, and then check for leaks.

CHANGING THE OIL

1. For best results, change fluid once a year.
2. Repeat statement #2 under "How to Fill Reservoir", and then pour used fluid into a seal able container.
3. Fill with Simplex oil. Reinstall oil filler plug.

LUBRICATION

(When no In-Line Oilier is used)

1. When used daily, pour a teaspoon of good quality air tool oil #10 or #20 wt. non-detergent oil into the air source inlet of pump. Connect hydraulic hose to application, connect air source to pump and operate pump a few seconds to evenly distribute fluid.
2. Use light machine oil to lubricate pivot points, hinges etc.

NOTE: NEVER OPERATE PUMP WHILE DISCONNECTED FROM APPLICATION. IF OPERATED IN THIS CONDITION, THE HOSE AND CONNECTIONS BECOME PRESSURIZED. THIS INCREASES THE BURST HAZARD AND DAMAGE MAY OCCUR TO PUMP / COMPONENTS.

TROUBLESHOOTING

If poor performance is noted, check the following:

1. Air supply 90-175 PSI at no less than 7.8 CFM.
2. Check application: Must require less than 10,000 PSI to actuate.
3. Connections, Hydraulic and Air. Inspect and clean often.
4. Contact an AUTHORIZED SIMPLEX SERVICE CENTER if there are any problems NOTED with the equipment.

AIR POWERED HYDRAULIC FOOT PUMPS

EXPLODED VIEW

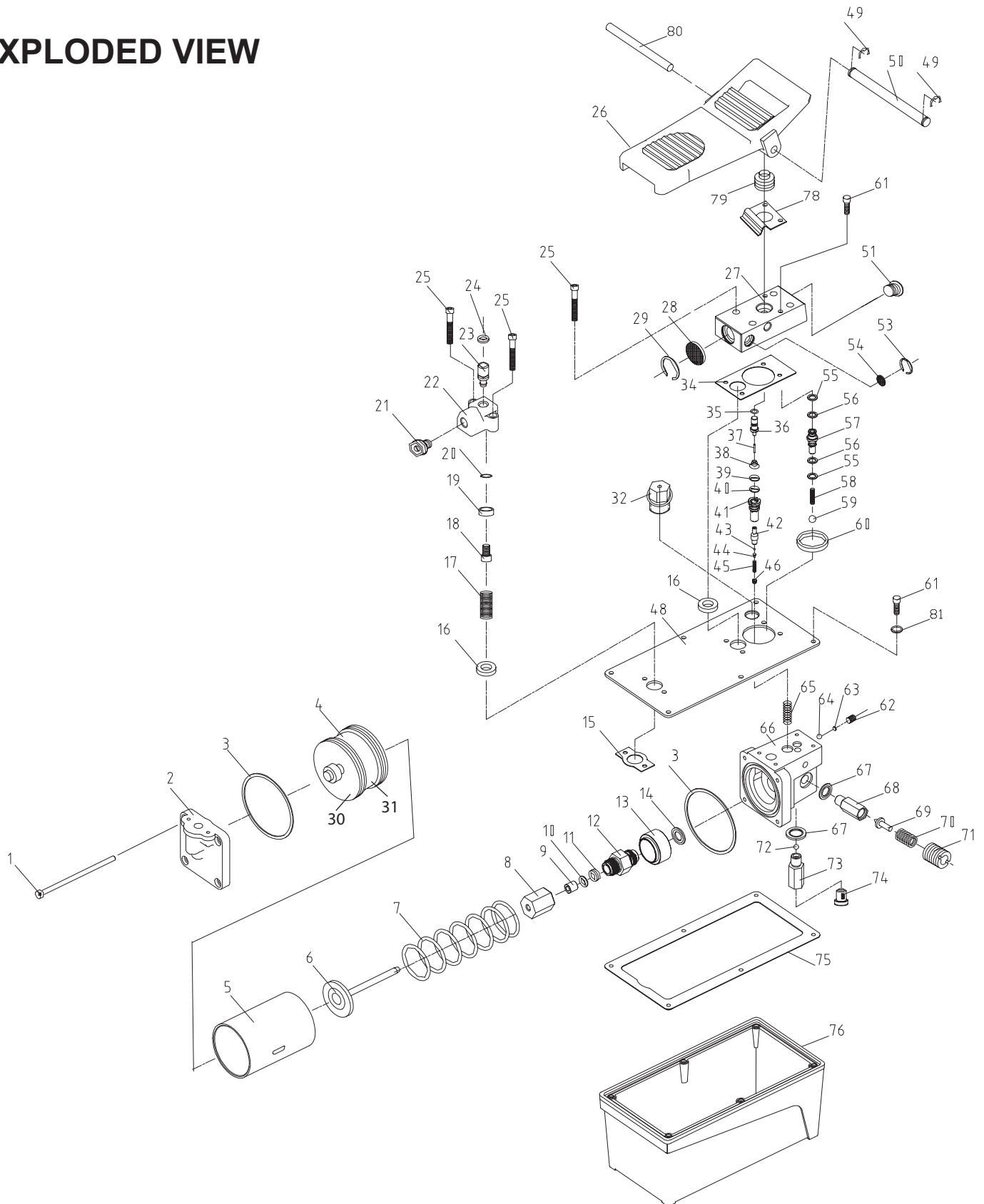

PART SHEET FOR PA91/95 SERIES FOOT PUMP

ITEM	PA91	PA95	DESCRIPTION	QTY
1	6066001	6066001	HEX BOLT	4
2	6066002	6066002	MOTOR COVER	1
3	*	*	WASHER	2
4	6066004	6066004	AIR PISTON ASSEMBLY	1
5	6066005	6066005	CYLINDER	1
6	6066006	6066077	PISTON ASSEMBLY	1
7	6066007	6066007	SPRING	1
8	6066008	6066008	PISTON COVER	1
9	*	*	BUSHING	1
10	*	*	BACK-UP RING	1
11	*	*	"U" CUP	1
12	6066011	44287	PUMP CYLINDER	1
13	6066012	6066012	WASHER	1
14	*	*	SPECIAL WASHER	1
15	*	*	PAD - B -	1
16	*	*	O-RING	2
17	*	*	SPRING	1
18	6066017	6066017	HEX BOLT	1
19	6066018	6066018	AIR ENTRANCE CAP	1
20	*	*	O-RING	1
21	6066020	6066020	PLASTIC CAP (AIR END)	1
22	6066021	6066021	AIR ENTRANCE BASE	1
23	6066022	6066022	AIR ENTRANCE VALVE	1
24	*	*	O-RING	1
25	6066024	6066024	HEX BOLT	8
26	6066025	6066025	FOOT PEDAL	1
27	6066026	6066026	OIL OUTLET BASE	1
28	6066027	6066027	MUFFLER	1
29	*	*	"C" CLIP	1
30	*	*	O-RING	1
31	*	*	BACK-UP SEAL	1
32	6066031	6066031	AIR OUTLET BASE	1
33	---	---		1
34	*	*	PAD - A	1
35	*	*	O-RING	1
36	*	*	RELEASE BAR	1
37	*	*	RELEASE NEEDLE	1
38	6066033	6066033	SPRING	1
39	*	*	BACK-UP RING	1
40	*	*	O-RING	1

ITEM	PA91	PA95	DESCRIPTION	QTY
41	6066034	6066034	RELEASE BASE	1
42	6066035	6066035	RELEASE VALVE	1
43	*	*	STEEL BALL	1
44	*	*	SPRING CAP	1
45	*	*	SPRING	1
46	6066038	6066038	HEX BOLT	1
48	6066039	6066039	OIL TANK COVER	1
49	*	*	"E" CLIP	2
50	6066040	6066040	ALXE	1
51	6066041	6066041	PLUG	1
52	---	---		
53	*	*	"C" CLIP	1
54	6066044	6066044	MUFFLER	1
55	*	*	O-RING	2
56	*	*	BACK-UP RING	2
57	6066045	6066045	OIL OUTLET VALVE	1
58	*	*	SPRING	1
59	*	*	STEEL BALL	1
60	*	*	O-RING	1
61	6066049	6066049	HEX BOLT	8
62	6066050	6066050	HEX BOLT	1
63	6066051	6066051	SPRING CAP	1
64	6066052	6066052	STEEL BAL	1
65	*	*	SPRING	1
66	6066054	6066054	BASE	1
67	*	*	WASHER	2
68	6066055	6066055	HIGH PRESSURE VALVE	1
69	6066056	6066056	NEEDLE	1
70	*	*	SPRING	1
71	6066058	6066058	NUT	1
72	6066059	6066059	STEEL BALL	1
73	6066060	6066060	OIL ENTRANCE VALVE	1
74	*	*	FILTER	1
75	*	*	GASKET	1
76	6066062	6066062	OIL TANK	1
	54122	44309	REPAIR KIT	1
78	6066078	6066078	LEAF SPRING	1
79	6066079	6066079	DUST CAP	1
80	6066080	6066080	STEEL BAR	1
81	*	*	WASHER	6

* = contents of repair kit

PA91-1 and PA95-1 MODELS ONLY

ITEM	PA91-1	PA95-1	DESCRIPTION	QTY
	18135	18135	OIL	1
1	68259	44437	LOGO	2
2	44507	44509	MODEL LABEL	1
3	68511	68511	RESERVOIR	1
4	44265	44265	COVER PLATE	1
5	68608	68608	GASKET	1
6	86095	86095	SCREW	10
7	44280	44280	INTAKE TUBE	1
8	44303	44303	LOCKNUT	6
9	43942	44284	AIR PUMP	1
10	87283	87283	HOSE CLAMP	1

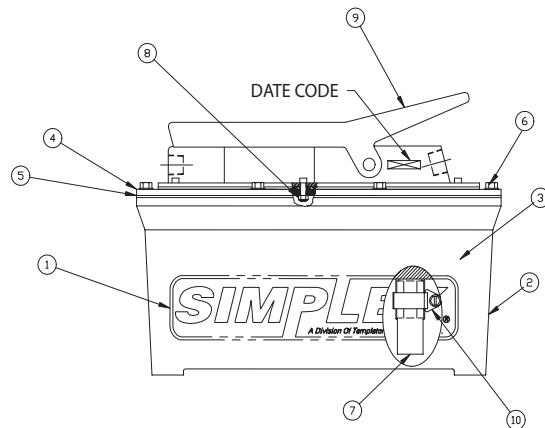

SIMPLEX products are warranted to be free of defects in materials and workmanship under normal use for as long as the original purchaser owns them, subject to the guidelines and limitations listed. This warranty does not cover: normal wear & tear, cosmetic items, abuse, overloading, alterations, improper fluid, or use in a manner for which they are not intended. If the customer believes a product is defective, the product must be delivered, or shipped freight prepaid, to the nearest SIMPLEX Authorized Service Center for evaluation and repair.

2525 GARDNER ROAD * BROADVIEW * ILLINOIS * 60155 * PHONE (708) 865-1500 * FAX (708) 865-0894