

Sears

OWNERS
MANUAL

MODEL NO.

CAUTION:
Read Rules for
Safe Operation
and Instructions
Carefully

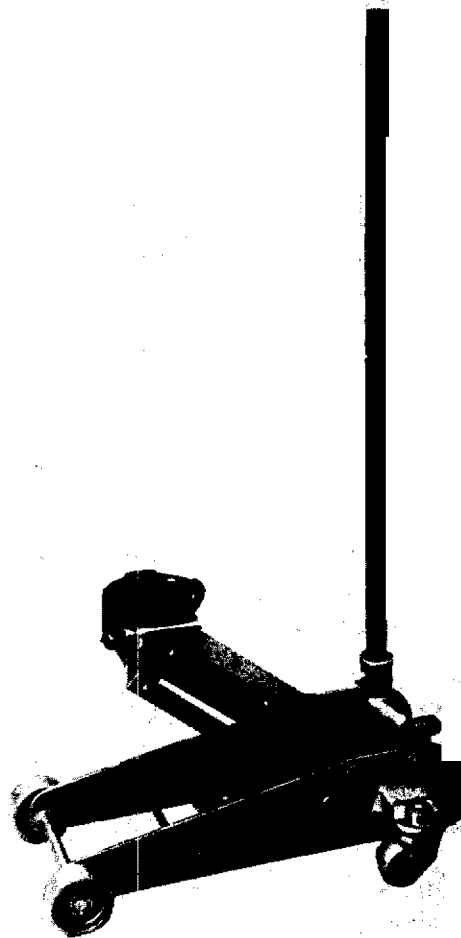

1 1/2 TON CAPACITY FLOOR SERVICE JACK

Operation
Repair Parts

Part No. 9010

RULES FOR SAFE OPERATION

IMPORTANT: Sometimes during shipment and/or handling, air gets into the hydraulic system, causing poor lifting performance. This is indicated by a springy feel as you pump the jack under a load. **PURGE ANY AIR FROM THE SYSTEM** by simply opening Release Valve (turn handle counter-clockwise) and operate pump handle rapidly several times.

CAUTION

THIS JACK IS DESIGNED FOR JACKING PURPOSES ONLY. POSITION JACK AT RIGHT ANGLE (90°) TO THE VEHICLE. AFTER JACKING, ALWAYS USE SAFETY STANDS TO SUPPORT LOAD BEFORE MAKING REPAIRS. **FOR YOUR SAFETY DO NOT OVERLOAD THIS JACK BEYOND ITS RATED CAPACITY.** CENTER LOAD ON SADDLE. BE SURE SETUP IS STABLE.

Raising the Jack

1. Close Release Valve **TIGHTLY** (by turning handle clockwise)
2. Position jack under load so that saddle will contact load firmly and is centered so it cannot slip.
3. Operate jack handle until saddle approaches contact with load. Once again check to see that saddle is correctly positioned.
4. Raise load to desired height. Transfer to Jack Stands if load is to be held up for an extended period.

Lowering the Jack

Open Release Valve **VERY SLOWLY** (by turning handle counter-clockwise). When Release Valve is opened, saddle can be easily lowered by the spring tension inside the frame.

CAUTION: Keep hands or feet away from the hinge mechanism of the jack.

Operating Principles

With Release Valve **TIGHTLY CLOSED:**

1. Upward stroke draws oil from Reservoir Tank into Plunger Cavity. Hydraulic pressure keeps Valve closed, keeping oil in cylinder.
2. Downward stroke of Plunger forces oil into Cylinder. Ram is forced out, raising saddle.

If load exceeds rated capacity, oil is automatically released back into Reservoir thru Safety Overload Valve.

3. When Ram reaches maximum stroke, oil is by-passed back into Reservoir, thus preventing overextended Ram Stroke.

When Release Valve is opened, oil is allowed to flow back into Reservoir, releasing hydraulic pressure on Ram and permitting saddle go be lowered.

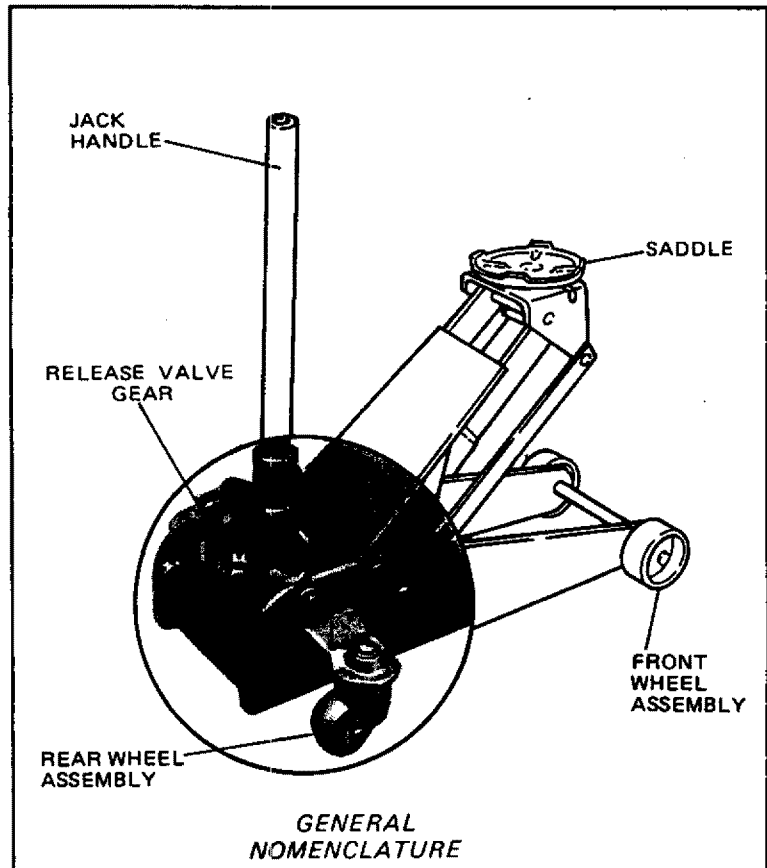

Fig. 1

MAINTENANCE PROCEDURES

Maintaining Oil Level

IMPORTANT: When adding or replacing oil, always use a good grade, Hydraulic Jack Oil. **DO NOT** use Brake Fluid, Alcohol, Glycerine, Detergent Motor Oil, or Dirty Oil. Improper fluid can cause serious internal damage to Jack.

Adding Oil: With Saddle fully lowered & jack on level ground, remove Filler Plug (See Fig. 2). Oil should be filled to level of oil filler plug hole. If low, add oil as needed.

Replacing Oil: To drain oil remove filler plug and release valve gear assembly. (See Fig. 3) Turn jack over and pour old oil out. While refilling, be very careful not to permit dirt or foreign matter to get into system. After refilling be sure to purge any air from the system by opening release valve (turn handle counter-clockwise) and operate pump handle rapidly several times.

Preventing Rust

Check Ram & Plunger every 3 months for any signs of rust or corrosion. Clean as needed and wipe with an oily cloth. When not using the jack, always leave the Saddle & Pump Plunger all the way down.

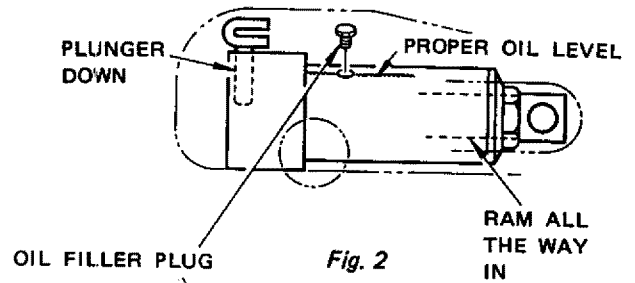

Fig. 2

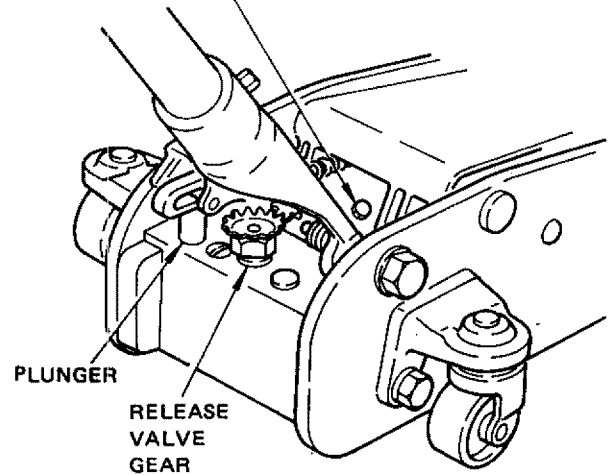

Fig. 3

TROUBLE SHOOTING (USING JACK WITHIN RATED LOAD CAPACITY)

TROUBLE	POSSIBLE CAUSE	REMEDY
Will not lift load at all	1) No or low Oil in system 2) Release Valve not closed 3) Power unit not functioning	1) Fill oil to prescribed level 2) Turn handle clockwise tightly 3) Replace power unit
Will lift load only part way Will lift load, but will not hold	4) Oil level low 5) Power unit leaking	4) Fill oil to prescribed level 5) Replace power unit
Jack will not lower	6) Release Valve stuck—probably dirt or foreign matter	6) Transfer load & clean Release Valve
Poor lifting	7) Dirty Oil 8) Air in Hydraulic System	7) Change Hydraulic Oil 8) Purge Air from system by opening Release Valve (turn handle counter-clockwise) and pumping handle several times.

REPAIR PARTS

Sears 1 1/2 Ton Floor Service Jack
Model Number 328.12190

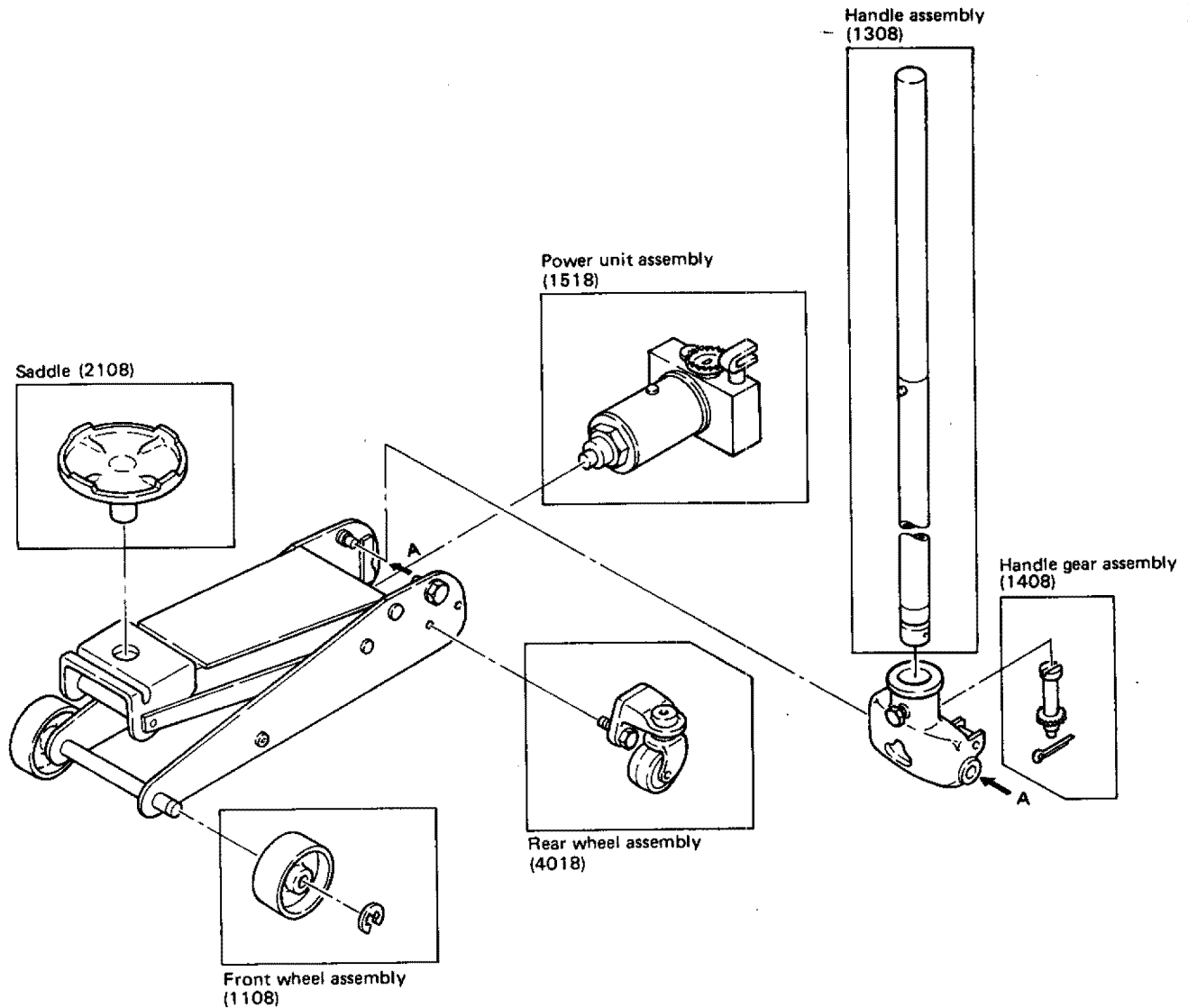

PARTS ARE AVAILABLE IN ASSEMBLIES ONLY (EXCEPT SADDLE)

Parts No.	Description	Parts No.	Description
1108	Front wheel assembly	2108	Saddle
1308	Handle assembly	4018	Rear wheel assembly
1408	Handle gear assembly	9010	Owners manual
1518	Power unit assembly		

Model Number

The Model Number and Serial Number will be found on the arm. Always mention the Model Number and Serial Number when requesting service or repair parts for your Jack.

How to Order Repair Parts

All assemblies listed herein may be ordered from any SEARS Service Center and Most Sears Stores.

WHEN ORDERING REPAIR PARTS, ALWAYS GIVE THE FOLLOWING INFORMATION:

- | | | | |
|-----------------|-----------|---------------------|------------------------------|
| 1. PART NUMBER | 328.12190 | 3. PART DESCRIPTION | 1 1/2 Ton Floor Service Jack |
| 2. MODEL NUMBER | | 4. NAME OF ITEM | |

IF THE PARTS YOU NEED ARE NOT STOCKED LOCALLY, YOUR ORDER WILL BE ELECTRONICALLY TRANSMITTED TO A SEARS REPAIR PARTS DISTRIBUTION CENTER FOR EXPEDITED HANDLING.