

Operator's Manual

**CRAFTSMAN®**

# 3<sup>1</sup>/<sub>2</sub> Ton Speedy Lift Garage Jack

Model 50357



**CUSTOMER HELP LINE**

Parts and Questions

**1-888-332-6419**

8:00 AM - 4:45 PM Central Time

Monday- Friday

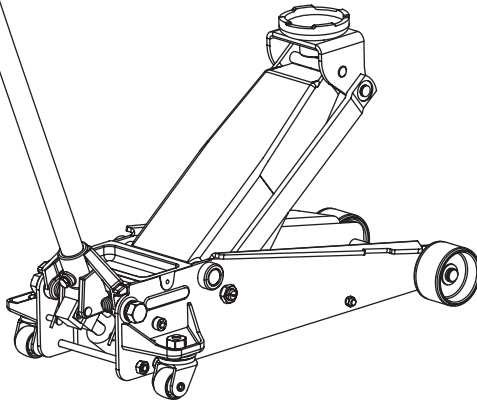

**WARNING:** Before using this product, read this Operator's Manual and follow all its Safety Rules and Operating Instructions.

- Safety
- Operation
- Assembly
- Maintenance
- Parts

Sears Brands Management Corporation, Hoffman Estates, IL 60179 U.S.A.  
[www.craftsman.com](http://www.craftsman.com)

Printed in China

## AIR PURGE PROCEDURE

**IMPORTANT: BEFORE FIRST USE**, perform the following Air Purge Procedure to remove any air that may have been introduced into the hydraulic system as a result of product shipment and handling.

- 1 REMOVE TOOL TRAY**  
Loosen and remove the two screws securing magnetic tool tray to jack frame. Remove magnetic tool tray to expose oil fill plug.
- 2 OPEN RELEASE VALVE**  
Place the open end of the handle over the handle socket so that the square-shaped slot engages the square bolt in the socket when inserted. Turn the handle counterclockwise 2 full turns.
- 3 RAPIDLY PUMP**  
Rapidly pump the handle 6 - 8 times. Leave handle in down position.
- 4 PURGE AIR**  
With a flat blade screwdriver, push the oil fill plug slightly to the side to purge trapped air from system. You should hear a hiss.
- 5 REPLACE COVER PLATE**  
Secure magnetic tool tray back in place with the two previously removed screws.
- 6 CLOSE RELEASE VALVE**  
Fully close release valve by turning handle clockwise until it stops.
- 7 READY FOR USE**  
Remove handle from handle socket. Jack is now ready to use. Check for proper pump action.

**NOTE:** Repeat this Air Purge Procedure whenever the jack displays reduced lifting performance.

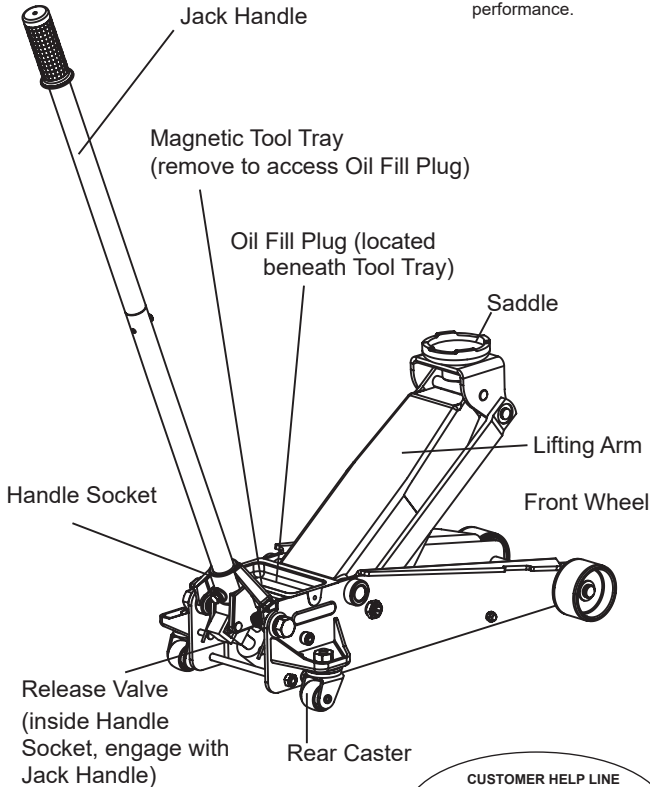

### CUSTOMER HELP LINE



Parts and Questions  
**1-888-332-6419**

8:00 AM - 4:45 PM Central Time  
Monday - Friday

**NOTE:** Repeat this Air Purge Procedure whenever the jack displays reduced lifting performance.

## SAFETY INSTRUCTIONS

### Read Operating Instructions

Study, understand and follow all instructions in this manual before operating the jack. Failure to heed these warnings may result in loss of load, damage to the jack and/or jack failure resulting in personal injury or property damage.

### Position the Jack

This jack is designed only for lifting part of the total vehicle. Position the jack to only lift on the areas of the vehicle specified by the vehicle manufacturer.

### Use Support Stands

After lifting the vehicle always support the load with appropriately rated vehicle support stands before working on the vehicle.

### Do Not Overload Jack

Do not overload this jack beyond its rated capacity. Overloading this jack beyond its rated capacity can cause damage to or failure of the jack.

### Use on Hard Level Surface

This jack is designed only for use on hard level surfaces capable of sustaining the load. Use on other than hard level surfaces can result in jack instability and possible loss of load.

### Center Load on Jack Saddle

Center load on jack saddle before lifting vehicle. Off-center loads and loads lifted when the jack is not level can cause loss of load or damage to the jack. Only use on vehicles whose lift points fit well with saddle of this jack.

### Do Not Use Jack as Dolly

Do not move or dolly the vehicle while it is on the jack. Do not use this jack to lift or move a building, mobile home or travel trailer of any type.

**KEEP HANDS AND FEET CLEAR OF THE JACK HINGE MECHANISM AND GROUND CONTACT AREA WHEN LOWERING THE LOAD!**

## CRAFTSMAN LIMITED WARRANTY

### CRAFTSMAN LIMITED WARRANTY

FOR ONE YEAR from the date of sale this product is warranty against defects in material or workmanship.

WITH PROOF OF SALE return a defective product to the retailer from which it was purchased for free replacement.

This warranty applies for only 90 days from the date of sale if this product is ever used while providing commercial services or if rented to another person.

This warranty gives you specific legal rights, and you may also have other rights which vary from state to state.

Sears Brands Management Corporation,  
Hoffman Estates, IL 60179

## DESCRIPTION

Craftsman model 50357 features a 7,000 lbs. maximum capacity. Lifting range for this jack is 5-1/2 inches to 22 inches.

### Specifications

Maximum load capacity.....3.5 tons (7,000 lbs.)  
Lift range.....5-1/2 to 22 inches  
Weight .....85 lbs.

**WARNING:** This product contains chemicals known to the state of California to cause cancer and birth defects or other reproductive harm. [www.P65Warnings.ca.gov](http://www.P65Warnings.ca.gov)

### THIS IS A LIFTING DEVICE ONLY!



DO NOT work on vehicle supported by jack. Immediately after lifting, support load with appropriately rated vehicle support stands before working on vehicle.

**PICTURE 1**

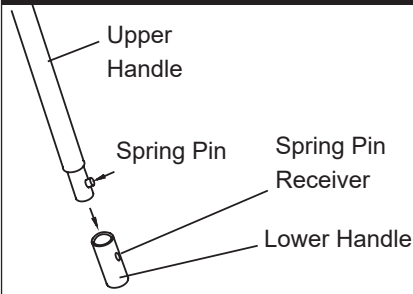

**PICTURE 2**

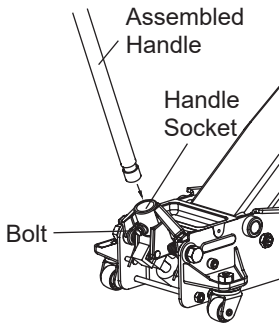

## PREPARATION

Compare these illustrations with your jack BEFORE operation and/or oil level maintenance to become familiar with the location of various jack components (page 2).

## ASSEMBLY

### Assembly

#### Handle Assembly

- Locate the spring pin on bottom end of upper handle and the spring pin receiver on the upper end of lower handle (Picture 1).
- Align the spring pin with the spring pin receiver. Connect the two handle pieces together by pressing the spring pin and insert until the spring pin is locked in the spring pin receiver.

**NOTICE:** ONLY use the handle provided with this jack. Handle is specially designed to properly fit into handle socket and engage release valve.

#### Handle Assembly

- Insert the assembled handle into the handle socket, until it is firmly seated.
- Tighten the bolt on handle socket to prevent accidental removal of handle while in use.

## FEATURES & OPERATION

### Operation

#### Raising the Jack

- Place vehicle in park, with emergency brake on and wheels securely chocked to ensure lifting stability.
- Refer to the vehicle manufacturer owner's manual to locate the approved vehicle lifting points.
- Position the jack so that the saddle will firmly contact the vehicle lifting point.
- Close the release valve by turning the handle clockwise until it stops.
- Pump jack handle until saddle nears contact with vehicle lifting point. Check to see that the saddle is centered and will contact lifting point firmly.
- Continue to pump jack handle to lift vehicle to desired height.
- After lifting, support the load with appropriately rated vehicle support stands before working on vehicle.

**WARNING:** Never work on, under, or around a load supported only by a hydraulic jack.

#### Lowering the Jack

- Raise load high enough to clear jack stands; then carefully remove the stands.
- Carefully open the release valve by slowly turning the handle counterclockwise.
- After removing jack from under vehicle, if saddle has not fully descended, push it all the way down to reduce ram exposure to rust and contamination.

### How it works

#### With Release Valve Closed

- An upward stroke of the jack Handle draws oil from the reservoir tank into the plunger cavity. Hydraulic pressure holds the valve closed, which keeps the oil in the plunger cavity.
- A downward stroke of the jack Handle releases oil into the lift cylinder, which forces the power unit ram out. This raises the saddle.

- When the ram reaches maximum extension, oil bypasses the lift cylinder through an overload valve back into the oil reservoir, protecting the jack from damage. This bypass system also goes into effect when the jack is overloaded (load exceeds 4,000 lbs) to protect the jack from damage and the user from possible serious injury.
- Opening the release valve allows oil to flow back into the reservoir. This releases hydraulic pressure on the ram, which results in lowering the saddle.

- When storing the jack, always have the saddle and pump plunger in the down position.

**ALWAYS USE A GOOD GRADE HYDRAULIC JACK OIL. DO NOT USE HYDRAULIC BRAKE FLUID, ALCOHOL, GLYCERINE, DETERGENT, MOTOR OIL OR DIRTY OIL. USE OF AN UNRECOMMENDED FLUID CAN CAUSE DAMAGE TO YOUR JACK.**

*Storage:*

Depress the spring lock to separate the handle pieces.

**MAINTENANCE**

**Maintenance**

*To Add Oil:*

- Position jack on the level ground and lower the saddle.
- Remove the oil fill plug.
- Fill the oil reservoir until oil level is just over the top surface of the inner cylinder. Replace oil plug.
- Perform Air Purge Procedure described on page 2.

*To Replace Oil:*

- Fully open release valve by turning handle counterclockwise as far as it will go.
- Remove the oil fill plug. Turn the jack over so that old oil will drain from the oil fill hole.
- Turn the jack back over after the oil has drained. Refill through oil fill hole. Keep dirt and other material clear when pouring. Fill to just beneath lower rim of hole. Replace oil fill plug.
- Perform Air Purge Procedure described on page 2.

*Lubrication:*

- Add lubricating oil (WD-40) to all moving parts when needed.
- For light duty use, lubricate every six months.
- For heavy and constant use, lubrication is recommended every month.

*Rust Prevention:*

- Check ram and pump plunger on the Power Unit Assembly every two months (or sooner, based on usage) for any signs of rust or corrosion. Lift the jack as high as it goes and look under and behind the lifting arm. If signs of rust are visible clean as needed and wipe down with with an oily cloth or cloth sprayed with WD-40.

**Air Purge Procedure**

During shipment, air may get into the hydraulic system causing reduced lifting performance. Perform Air Purge Procedure described on page 2.

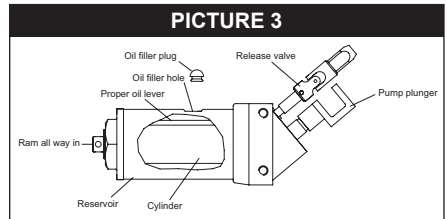

## EXPLODED VIEW AND PARTS LIST

#	Description	Qty.
1	Saddle	1
2	Power Unit Assembly	1
3	Handle Assembly	1
4	Front Wheel	2
5	Handle Socket Assembly	1
6	Rear Caster Assembly	2
7	Magnetic Tool Tray	1
8	Oil Fill Plug	1
-	Operators Manual	1
-	Warning Label	1

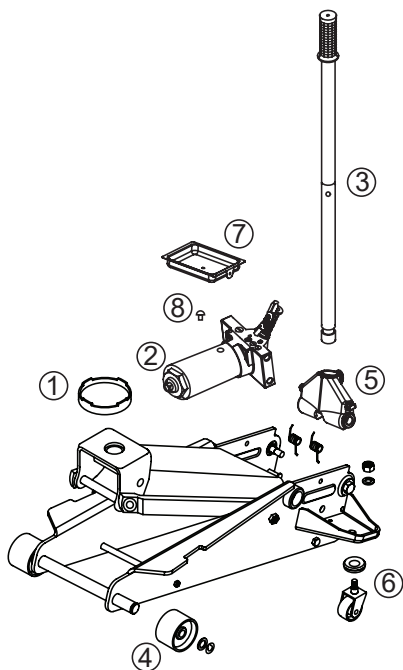

## TROUBLESHOOTING

Symptom							Probable Cause and Solution
Jack will not lift load	Jack will not hold load	Jack will not lift to full height	Jack will not lower completely	Poor jack lifting, pump feels spongy	Handle raises by itself while under load		
<b>X</b>	<b>X</b>	<b>X</b>		<b>X</b>		Oil level is low in jack. Add oil as required.	
<b>X</b>		<b>X</b>	<b>X</b>	<b>X</b>	<b>X</b>	Power unit may have trapped air. Release air from system.	
<b>X</b>	<b>X</b>	<b>X</b>				Release valve may not be closing properly. Turn the release valve clockwise tightly.	
			<b>X</b>			Oil reservoir is over-filled. Drain out some oil.	
			<b>X</b>			Lubrication of moving parts is necessary.	
<b>X</b>	<b>X</b>			<b>X</b>		Power unit is malfunctioning. Replace the power unit.	

# NOTE

---

---

---

---

---

---

---

---

---

---

---

---

---

---

---

---

---



For Help Line, Parts and Service:  
Call 8:00 am - 4:45 pm, CT, Monday - Friday  
1-888-332-6419

Para la línea de ayuda, partes y servicio:  
Llame de 8:00 am - 4:45 pm, CT, Lunes-Viernes  
1-888-332-6419