

Sears

**OWNERS
MANUAL**

**MODEL NO.
328.12040**

CAUTION:
Read Rules for
Safe Operation
and Instructions
Carefully

Parts NO. 9004

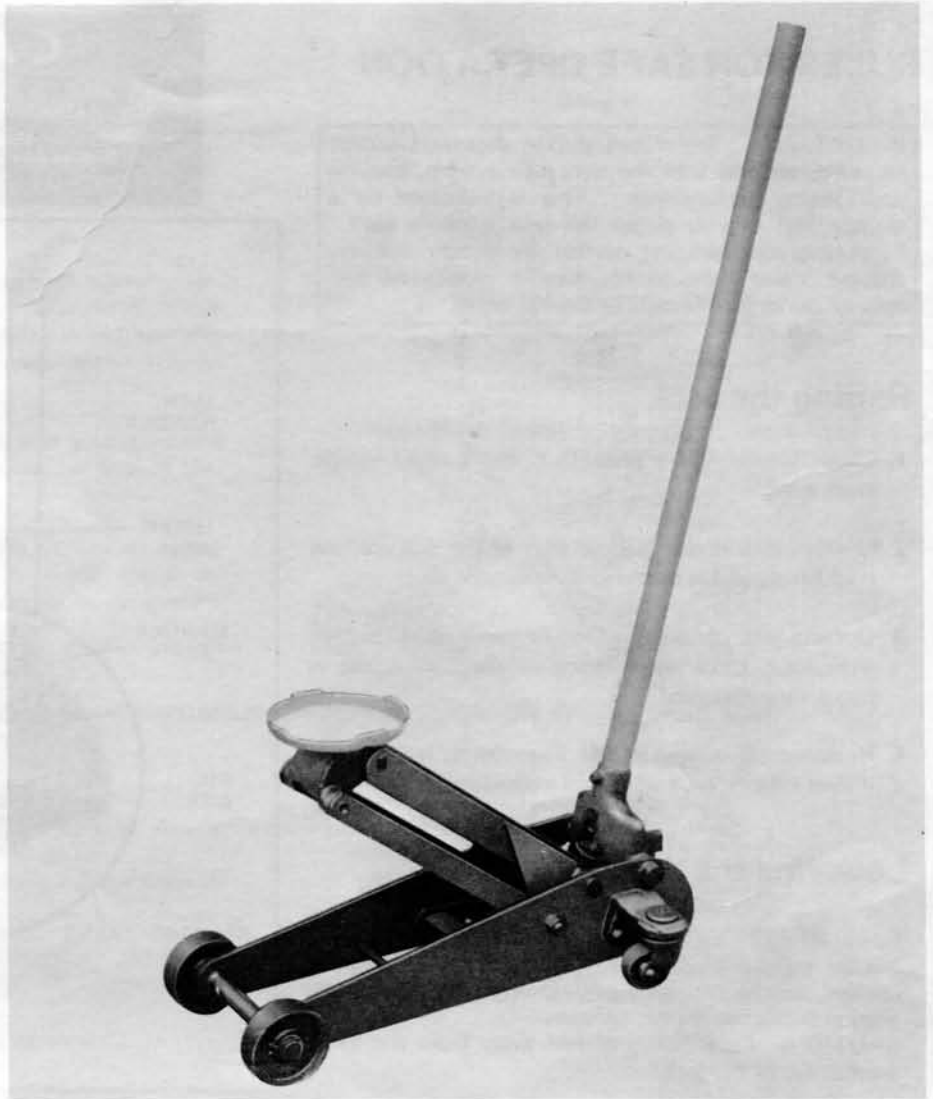

2 TON CAPACITY FLOOR SERVICE JACK

Operation
Repair Parts

Sears, Roebuck and Co., Chicago, IL. 60684 U.S.A.

Printed in Japan

RULES FOR SAFE OPERATION

IMPORTANT: Sometimes during shipment and/or handling, air gets into the hydraulic system, causing poor lifting performance. This is indicated by a springy feel as you pump the jack under a load. Purge any air from the system by simply opening Release Valve (turn handle counter-clockwise) and operate pump handle rapidly several times.

Raising the Jack

1. Close Release Valve **TIGHTLY** (by turning handle clockwise)
2. Position jack under load so that saddle will contact load firmly and is centered so it cannot slip.
3. Operate jack handle until saddle approaches contact with load. Once again check to see that saddle is correctly positioned.
4. Raise load to desired height. Transfer to Jack Stands if load is to be held up for an extended period.

Lowering the Jack

Open Release Valve **VERY SLOWLY** (by turning handle counter-clockwise). When Release Valve is opened, saddle can be easily lowered by the spring tension inside the frame.

CAUTION: Keep hands or feet away from the hinge mechanism of the jack.

HYDRAULIC SYSTEM PARTS

- (A) JACK HANDLE
- (B) PLUNGER
- (C) TANK, RESERVOIR
- (D) OIL STRAINER
- (E) SUCTION VALVE
- (F) DELIVERY VALVE
- (G) CYLINDER
- (H) RELEASE VALVE
- (I) GEAR-DRIVE, RELEASE VALVE
- (J) GEAR-DRIVEN, RELEASE VALVE
- (K) SAFETY OVERLOAD VALVE
- (L) BY-PASS VALVE
- (M) RELEASE SPRING
- (N) RAM

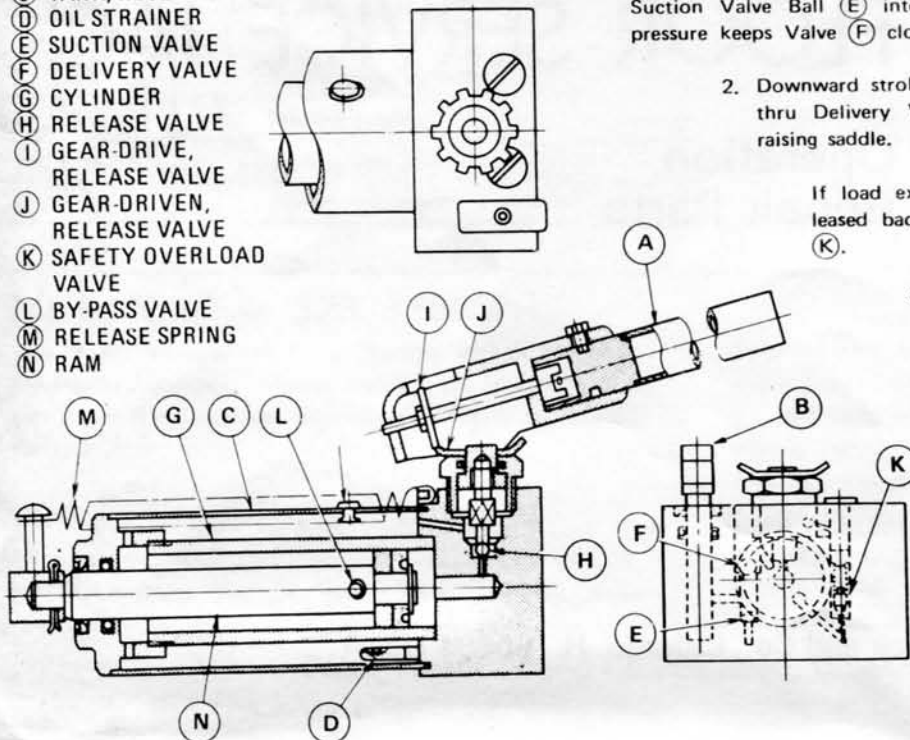

CAUTION

THIS JACK IS DESIGNED FOR JACKING PURPOSES ONLY. AFTER JACKING, ALWAYS USE SAFETY STANDS TO SUPPORT LOAD BEFORE MAKING REPAIRS. **FOR YOUR SAFETY-DO NOT OVERLOAD THIS JACK BEYOND ITS RATED CAPACITY.**

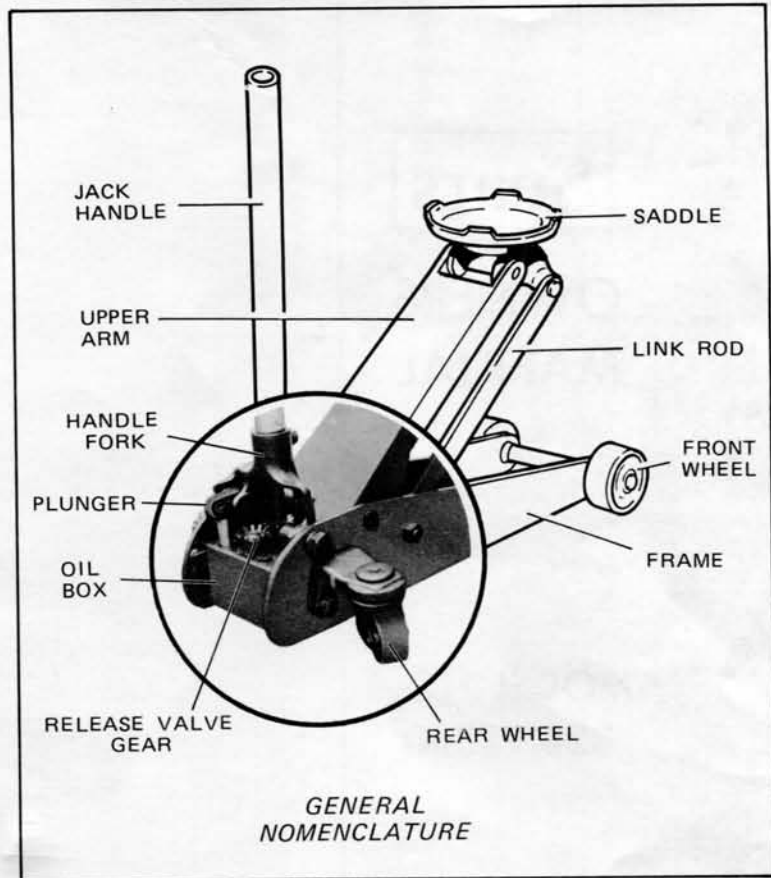

Operating Principles

With Release Valve (H) **TIGHTLY CLOSED:**

1. Upward stroke draws oil from Reservoir Tank (C) thru Suction Valve Ball (E) into Plunger Cavity. Hydraulic pressure keeps Valve (F) closed, keeping oil in cylinder.
2. Downward stroke of Plunger (B) forces oil into Cylinder thru Delivery Valve Ball (F). Ram (N) is forced out, raising saddle.

If load exceeds rated capacity, oil is automatically released back into Reservoir thru Safety Overload Valve (K).

3. When Ram (N) reaches maximum stroke, oil is by-passed back into Reservoir thru By-Pass Valve (L), thus preventing over-extended Ram Stroke.

When Release Valve (H) is opened, oil is allowed to flow back into Reservoir, releasing hydraulic pressure on Ram and permitting saddle to be lowered.

MAINTENANCE PROCEDURES

Maintaining Oil Level

IMPORTANT: When adding or replacing oil, always use a good grade, Hydraulic Jack Oil (or transmission oil, turbine oil, etc.). Avoid mixing types of oil. DO NOT use Brake Fluid, Alcohol, Glycerine, detergent motor oil, or dirty oil. Improper fluid can cause serious internal damage to Jack.

Adding Oil: With Saddle fully lowered & jack on level ground, remove Filler Cap. Oil level should be approx. 3/16" below cap hole. If low, add oil as needed.

Replacing Oil: for better performance & long life, replace oil supply once a year. To drain oil, remove Filler Plug & Release Valve. BE VERY CAREFUL not to permit dirt or foreign matter to get into the system.

Lubrication

Add grease to Upper Arm Grease Fitting every 3 months.

Preventing Rust

Check Ram & Plunger every 3 months for any signs of rust or corrosion. Clean as needed and wipe with an oily cloth.

When not using the jack, always leave the Saddle & Pump Plunger all the way down.

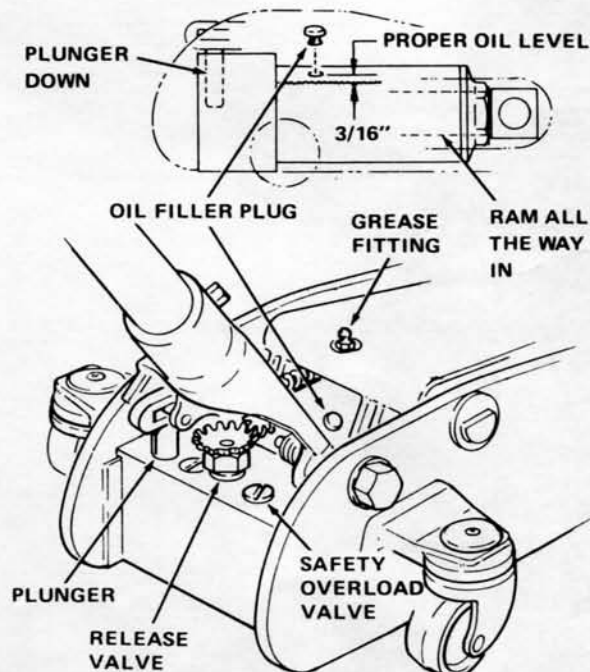

(Factory adjusted – do not attempt to replace any components in this power unit. The complete assembly must be replaced as a factory pretested assembly.)

TROUBLE SHOOTING (USING JACK WITHIN RATED LOAD CAPACITY)

TROUBLE	POSSIBLE CAUSE	REMEDY
Will not lift load at all	1) No Oil in system 2) Release Valve not closed 3) Delivery Valve and/or By-Pass Valve not functioning 4) Defective Packings ("O" rings)	1) Fill to prescribed level 2) Turn handle clockwise tightly 3) Check for dirt or foreign matter – clean 4) Replace Packings
Will lift load only part way	5) Oil level low	5) Fill to prescribed level
Will lift load, but will not hold	6) The following Valve or Valves leaking: (a) Suction Valve, (b) Delivery Valve, (c) Release Valve, (d) By-Pass Valve 7) Packings worn out or defective	6) Inspect Valves – clean and adjust as needed 7) Replace Packings
Jack will not lower	8) Release Valve stuck – probably dirt or foreign matter	8) Transfer load & clean Release Valve
Poor lifting	9) Defective Pump Packings and/or Valves malfunctioning. 10) Dirty Oil 11) Air in Hydraulic System	9) Clean Valves, replace Packings 10) Change Hydraulic Oil 11) Purge Air from system

REPAIR PARTS

Sears 2 Ton Floor Service Jack
Model Number 328.12040

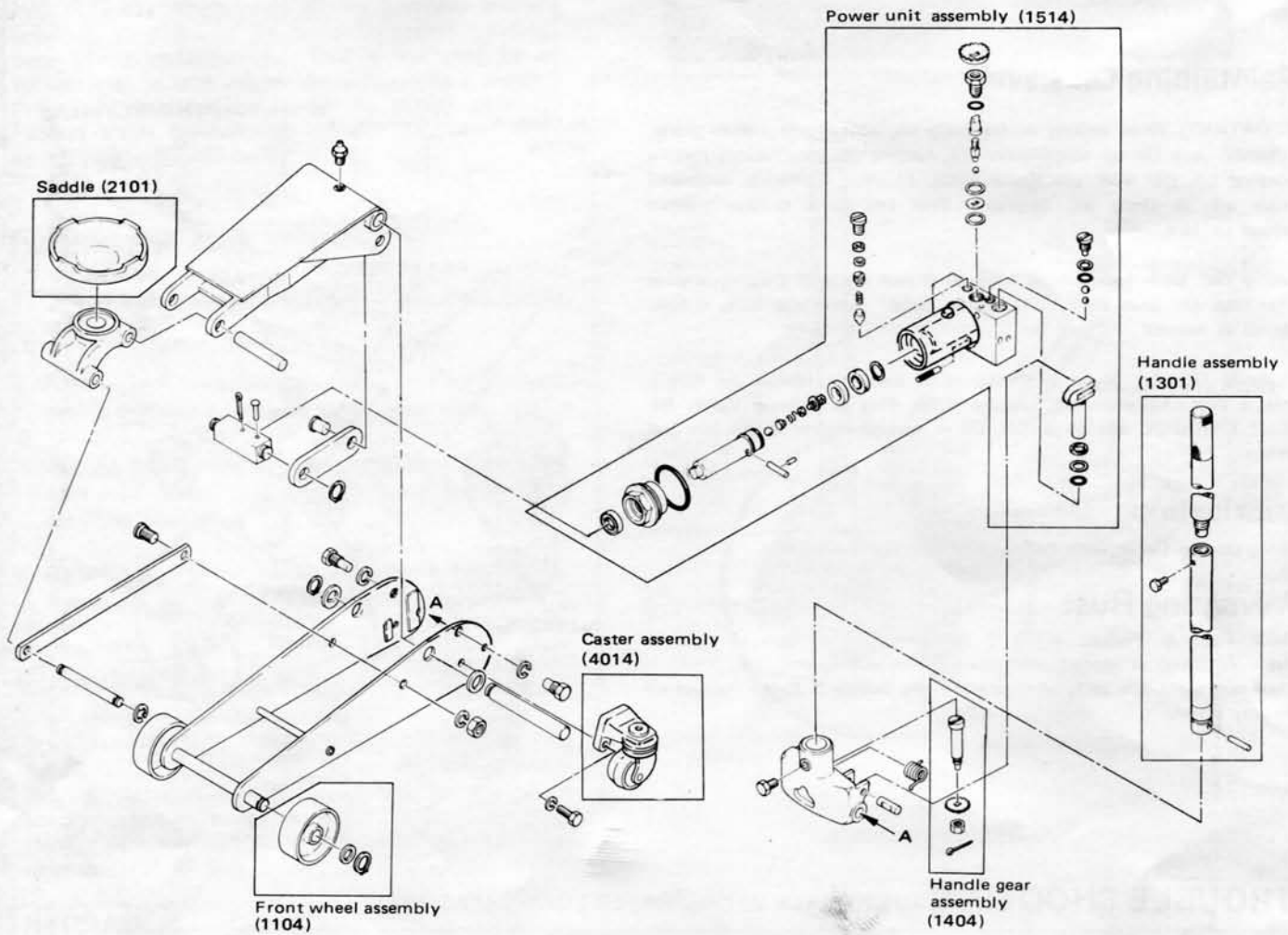

PARTS ARE AVAILABLE IN ASSEMBLIES ONLY (EXCEPT SADDLE)

Parts No.	Description	Parts No.	Description
1104	Front wheel assembly	2101	Saddle
1301	Handle assembly	4014	Caster assembly
1404	Handle gear assembly	9004	Owners manual
1514	Power unit assembly		

Model Number 328.12040

The Model Number and Serial Number will be found on the Frame Assembly. Always mention the Model Number and Serial Number when requesting service or repair parts for your Jack.

How to Order Repair Parts

All assemblies listed herein may be ordered from SEARS, ROEBUCK AND CO., c/o Repair Parts Dept. 98. When

ordering parts by mail, selling prices will be furnished on request, or parts will be shipped at current selling prices and you will be billed accordingly.

WHEN ORDERING REPAIR PARTS, ALWAYS GIVE THE FOLLOWING INFORMATION:

1. PART NUMBER
2. MODEL NUMBER
328.12040
3. PART DESCRIPTION
4. NAME OF ITEM
2 Ton Floor Service Jack

Sears, Roebuck and Co., Chicago, IL. 60684 U.S.A.