

SEARS

**OWNER'S
MANUAL**

**MODEL NO.
214.50135**

*Save this manual for
future reference*

CAUTION:
Carefully Read
Instructions and
Procedures for Safe
Operation

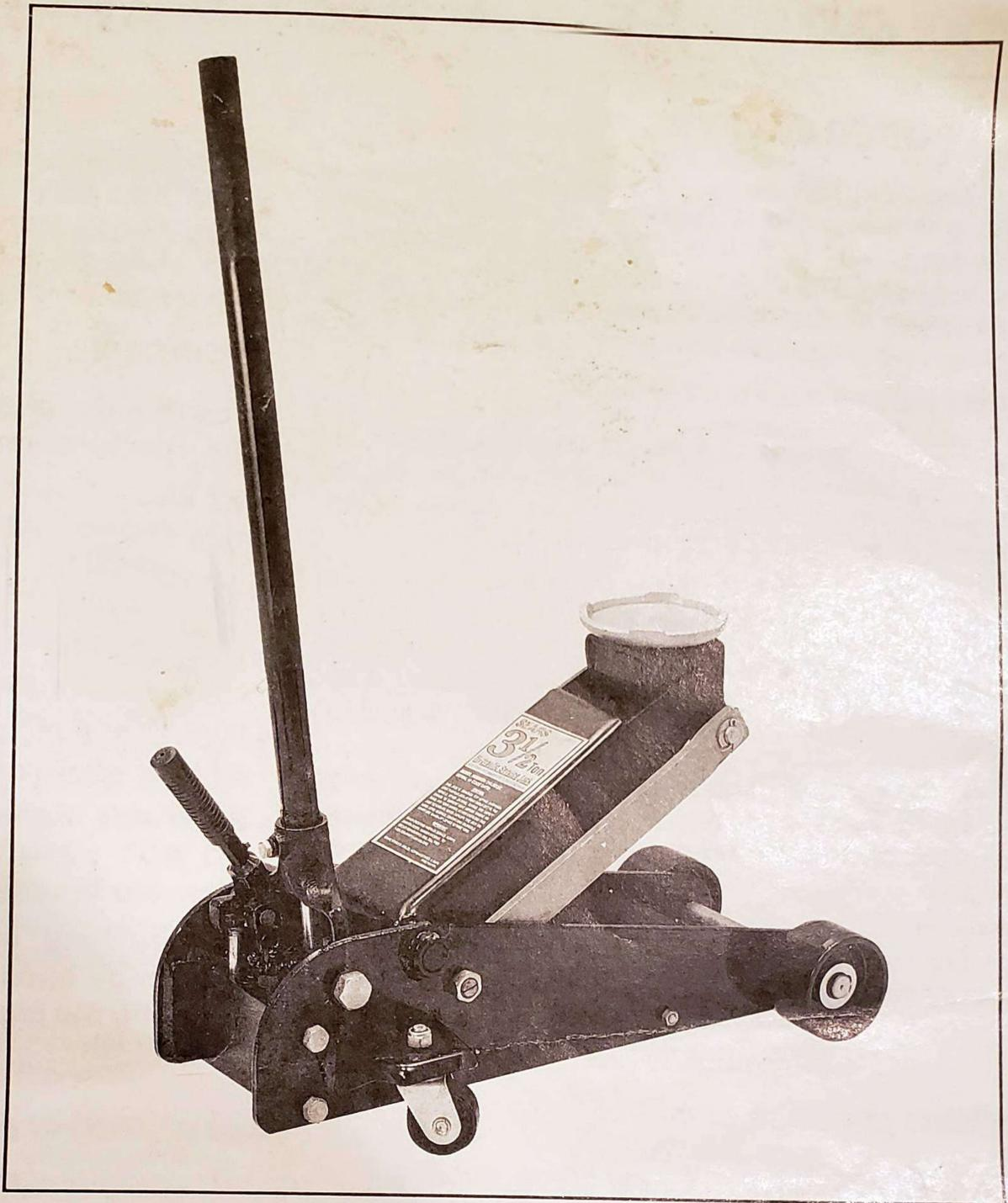

**3 1/2 TON CAPACITY
SERVICE JACK** WITH PATENTED
Speedy-Lift™ LEVER

*Meets Guidelines of American National Standard
ASME/ANSI PALD-10B-1993 – SERVICE JACKS*

**Operation
Maintenance
Repair Parts
Warranty**

SEARS, ROEBUCK AND CO., Hoffman Estates, IL 60179 U.S.A.

OPERATION AND MAINTENANCE

OPERATING PRINCIPLES

The *Speedy-Lift*[™] lever eliminates the nuisance of having to pump the jack handle numerous times to raise the saddle to point of contact with the load.

The *Speedy-Lift*[™] lever is to be used only to assist positioning of the saddle, and NOT for lifting the load.

With release valve CLOSED:

- An upward stroke of the jack handle draws oil from the reservoir tank into the plunger cavity. Hydraulic pressure holds the valve closed, which keeps the oil in the plunger cavity.
- A downward stroke of the jack handle release oil into the cylinder, which forces the ram out. This raises the saddle. (NOTE: if the load exceeds the rated capacity, oil is automatically released back into the reservoir through the safety overload valve.)
- When the ram reaches maximum extension, oil is bypassed back into the reservoir to prevent an overextended ram stroke and possible damage to the jack.
- Opening the release valve allows oil to flow back into the reservoir. This release hydraulic pressure on the ram, which results in lowering the saddle.

OPERATION

RAISING the Jack:

- Block the vehicle's wheels for lifting stability.
- Refer to the vehicle manufacturer owners manual to locate approved lifting points on the vehicle. Position jack so that the saddle (see Fig. 1) is centered under the load at an appropriate lift point.

USING Speedy-Lift[™] Lever

- NEVER USE *Speedy-Lift*[™] DEVICE TO RAISE LOAD.
- Close release valve by turning jack handle clockwise until firm.
- Position jack under vehicle, pump *Speedy-Lift*[™] lever until saddle NEARS contact with the lift point. Check to see that the saddle is centered and will contact the lifting point firmly.
- After lift point is contacted, use jack handle to raise vehicle to desired height, then support the load with appropriately rated vehicle support stands BEFORE working on the vehicle.

LOWERING the Jack

Open the release valve VERY SLOWLY by turning the jack handle counter-clockwise.

CAUTION: Keep hands and feet clear of the jack hinge mechanism and ground contact area when lowering the load!

MAINTAINING OIL LEVEL

When adding or replacing oil, ALWAYS use a good grade Hydraulic Jack oil. DO NOT use Hydraulic Brake Fluid, Alcohol, Glycerine, Detergent Motor Oil or dirty oil. Use of an improper fluid can cause serious internal damage to your jack.

ADDING OIL:

- Position the jack on level ground and fully lower the saddle. Remove oil filler plug (See Fig. 2).
- Oil should be filled to the level of the oil filler plug hole. If low, add oil as needed.

REPLACING OIL:

- To drain oil, remove oil filler plug and open release valve. (See Fig. 2)
- Turn jack over and drain old oil out through the oil filler plug hole.
- Refill with new oil through the oil filler plug hole. DO NOT allow dirt or other foreign material to enter the hydraulic system when filling.
- After refilling, remove any air from the hydraulic system by opening the release valve and rapidly pumping the jack handle several times.

LUBRICATION

Add lubricating oil to all moving parts as needed.

PREVENTING RUST

- Check ram and pump plunger (See Fig. 2) every few months for any signs of rust or corrosion. Clean as needed and wipe with an oily cloth.
- When not in use. ALWAYS store jack with saddle and pump plunger lowered all the way down.

SAFETY PRECAUTIONS & WARRANTY



WARNING



- This jack is a lifting device designed **ONLY** for lifting part of the total vehicle (ie., one wheel). Do not move or dolly the vehicle while it is on the jack.
- Position this jack to **ONLY** lift on the areas of the vehicle as specified by the vehicle manufacturer.
- After lifting the vehicle, **ALWAYS** support the load with appropriately rated vehicle support stands **BEFORE** working on the vehicle.
- Do not overload this jack beyond its rated capacity. Overloading can cause damage to or failure of the jack.
- This jack is designed **ONLY** for use on hard level surfaces capable of sustaining the load. Use on other than hard level surfaces can result in jack instability and possible loss of load.
- Center load on jack saddle **BEFORE** lifting vehicle. Off-center loads and loads lifted when the jack is not level can cause loss of load or damage to the jack.
- Study, understand and follow all instructions in this manual **BEFORE** operating the jack.
- Failure to heed these warnings may result in loss of load, damage to the jack and/or jack failure resulting in personal injury or property damage.
- Do not use this jack for any purpose other than that for which it is designed.
- **NEVER USE Speedy-Lift™ DEVICE TO RAISE LOAD.**

FULL ONE YEAR WARRANTY

If within one year from date of purchase, this service jack fails due to a defect in material or workmanship, **RETURN IT TO THE NEAREST SEARS STORE IN THE UNITED STATES** and Sears will replace it, free of charge.

If this service jack is used for commercial or rental purposes, this warranty will apply for only 30 days from date of purchase.

This warranty gives you specific legal rights, and you may also have other rights which vary from state to state.

SEARS, ROEBUCK AND CO., D/817 WA
Hoffman Estates, IL 60179.

KNOW YOUR JACK

FIG. 1

Compare these illustrations with your jack **BEFORE** operation to become familiar with the location of various jack components.

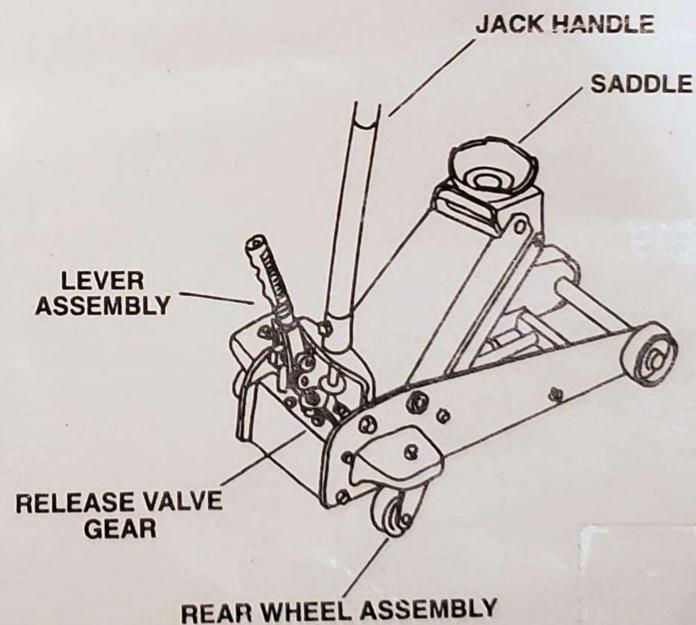
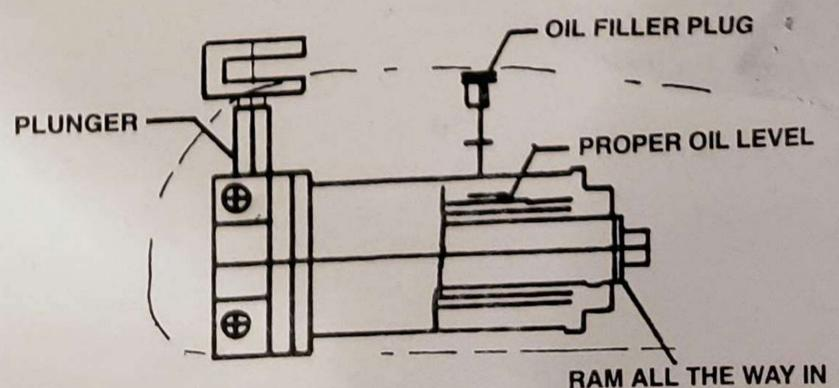

FIG. 2



CAUTION BEFORE USE



Occasionally during shipment and/or handing, air gets trapped in the hydraulic system, which interferes with the jack's lifting performance.

To release air from the hydraulic system:

- Open the release valve by turning the jack handle (See Fig. 1) counter-clockwise.
- Remove oil filler plug. (See Fig. 2)
- Rapidly pump jack handle through several full strokes.
- Replace oil-filler plug.

REPAIR PARTS

Sears 3 1/2 Ton Service Jack
Model Number 214.50135

Model Number
214.50135

The Model Number and Serial Number will be found on or near the lifting arm. Always mention the Model Number and Serial Number when requesting service or repair parts for your Jack.

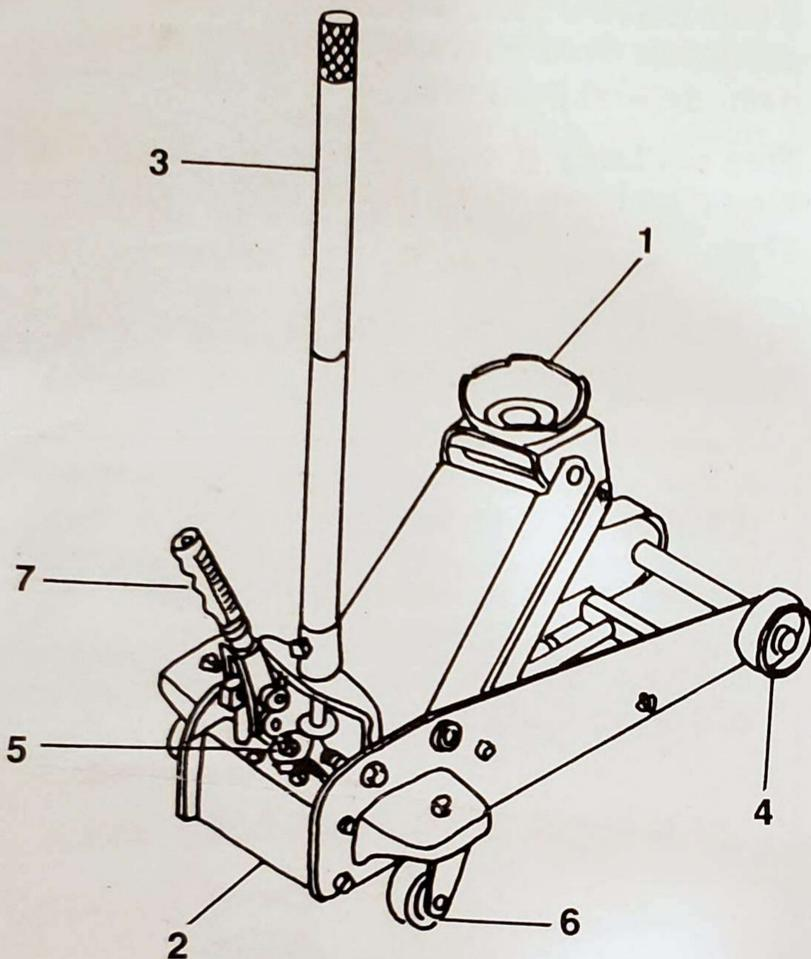

PARTS ARE ONLY AVAILABLE IN ASSEMBLIES (except Saddle)

Key	Parts No.	Description
1	4955	Saddle
2	4954	Power unit assembly
3	4952	Jack handle assembly
4	4951	Front wheel assembly
5	4953	Jack handle gear assembly
6	4956	Rear wheel assembly
7	4957	Lever assembly
	4958	Owners manual

HOW TO ORDER REPAIR PARTS

All assemblies listed above may be ordered from any Sears Service Center and most Sears stores.

WHEN ORDERING REPAIR PARTS. ALWAYS GIVE THE FOLLOWING INFORMATION:

- Repair Part Number
- Repair Part Description
- Model Number 214.50135
- Name of Item: 3 1/2 Ton Service Jack with Patented *Speedy-Lift™* Lever

To Order Toll Free 1-800-FON-PARTS
(1-800-366-7278)

PROBLEM-SOLVING HINTS

POSSIBLE JACK PROBLEMS						POSSIBLE CAUSES AND SOLUTIONS (Refer to Operation and Maintenance procedures for detailed information)
Jack will not lift load	Jack will lift load, but will not hold	Jack will not lower completely	Poor jack lifting. Pump feels spongy	Jack will not lift to full height	Handle raises by itself when jack is under load	
X						Release valve not tightly closed. To close or tighten, turn release valve clockwise.
			X	X	X	Air is in hydraulic system. Release air from system.
X	X		X	X		Oil level is low in jack. Add oil as required.
		X				<ul style="list-style-type: none"> ● Oil reservoir is over-filled. Drain out some oil. ● Lubrication of moving parts is necessary.
X	X		X			Power unit is malfunctioning. Replace the power unit.