

SEARS

**OWNERS
MANUAL**

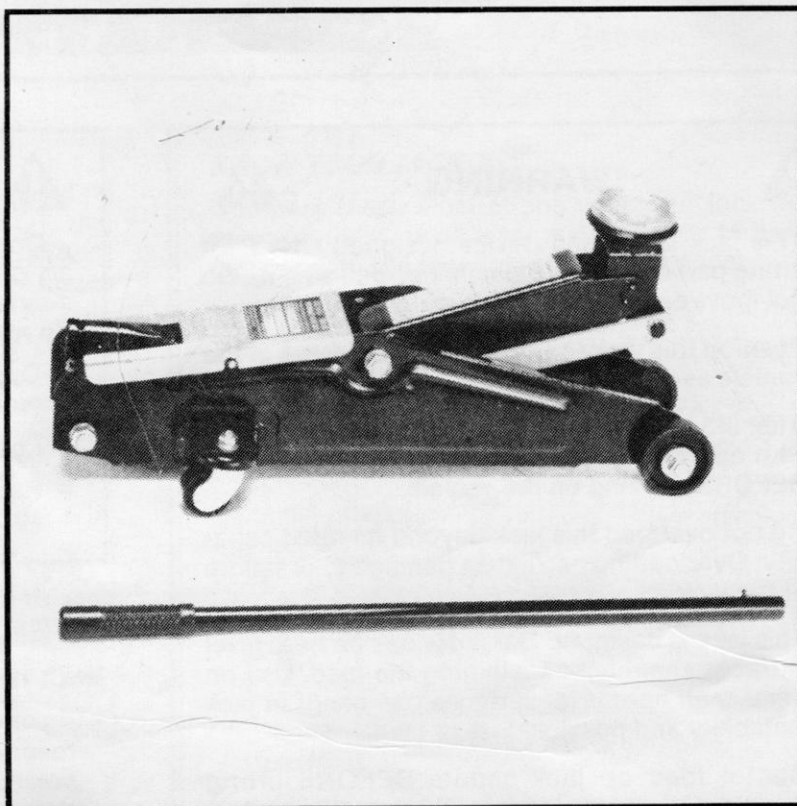

**MODEL NO.
214.50111**

**4500 LBS.
CAPACITY
SERVICE JACK**

**CAUTION:
Carefully Read
Instructions and
Procedures for
Safe Operation**

*Meets Guidelines of American National Standard
ASME/ANSI PALD-10-1988 — SERVICE JACKS*

**Operation
Maintenance
Repair Parts
Warranty**

OPERATION



WARNING



- This jack is a lifting device designed **ONLY** for lifting part of the total vehicle (ie., one wheel). Do not move or dolly the vehicle while it is on the jack.
- Position this jack to **ONLY** lift on the areas of the vehicle as specified by the vehicle manufacturer.
- After lifting the vehicle, **ALWAYS** support the load with appropriately rated vehicle support stands **BEFORE** working on the vehicle.
- Do not overload this jack beyond its rated capacity. Overloading can cause damage to or failure of the jack.
- This jack is designed **ONLY** for use on hard level surfaces capable of sustaining the load. Use on other than hard level surfaces can result in jack instability and possible loss of load.
- Center load on jack saddle **BEFORE** lifting vehicle. Off-center loads and loads lifted when the jack is not level can cause loss of load or damage to the jack.
- Study, understand and follow all instructions in this manual **BEFORE** operating the jack.
- Failure to heed these warnings may result in loss of load, damage to the jack and/or jack failure resulting in personal injury or property damage.



CAUTION BEFORE USING



Occasionally during shipment and/or handling, air gets trapped in the hydraulic system, which interferes with the jack's lifting performance.

To release air from the hydraulic system:

- Open the release valve by turning the jack handle (see Fig. 1) counter-clockwise.
- Loosen oil filler plug.
- Rapidly pump jack handle through several full strokes.

OPERATING PRINCIPLES

With release valve CLOSED:

- An upward stroke of the jack handle draws oil from the reservoir tank into the plunger cavity. Hydraulic pressure holds the valve closed, which keeps the oil in the plunger cavity.
- A downward stroke of the jack handle releases oil into the cylinder, which forces the ram out. This raises the saddle. (**NOTE:** If the load exceeds the rated capacity, oil is automatically released back into the reservoir through the safety overload valve.)
- When the ram reaches maximum extension, oil is by-passed back into the reservoir to prevent an over-extended ram stroke and possible damage to the jack.
- Opening the release valve allows oil to flow back into the reservoir. This releases hydraulic pressure on the ram, which results in lowering the saddle.

KNOW YOUR JACK

Compare these illustrations with your jack **BEFORE** operation to become familiar with the location of various jack components.

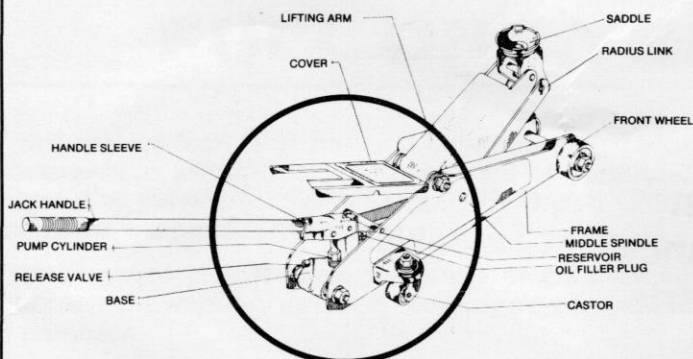

FIG. 1

OPERATION

RAISING the Jack:

- With notched end of the jack handle (see Fig. 1), close release valve by turning the handle clockwise.
- Block the vehicle's wheels for lifting stability.
- Refer to the vehicle manufacturer owners manual to locate approved lifting points on the vehicle. Position jack so that the saddle (see Fig. 1) is centered under the load at an appropriate lift point.
- Pump jack handle until saddle **NEARS** contact with the vehicle. Check to see that the saddle is centered and will contact the load lifting point firmly.
- Continue to pump the jack handle to lift the vehicle to the desired height. After lifting, support the load with appropriately rated vehicle support stands **BEFORE** working on the vehicle.

LOWERING the Jack:

- With notched end of jack handle, **SLOWLY** open the release valve by turning the handle counter-clockwise.

CAUTION: KEEP HANDS AND FEET CLEAR OF GROUND CONTACT AREA WHEN LOWERING THE LOAD!

MAINTENANCE

MAINTAINING OIL LEVEL

Important Note: When adding or replacing oil, **ALWAYS** use a good grade Hydraulic Jack oil. **DO NOT** use Hydraulic Brake Fluid, Alcohol, Glycerine, Detergent Motor Oil or dirty oil. Use of an improper fluid can cause serious internal damage to your jack.

ADDING Oil:

- Position the jack on level ground and fully lower the saddle. Remove oil filler plug (See Fig. 2).
- Oil level should be just over the cylinder. If low, add oil as needed.

REPLACING Oil:

- To drain oil, remove oil filler plug and open release valve. Turn jack over and drain old oil out through the oil filler plug hole.
- Refill with new oil through the oil filler plug hole. **DO NOT** allow dirt or other foreign material to enter the hydraulic system when filling.
- After refilling, remove any air from the hydraulic system by opening the release valve and rapidly pumping the jack handle several times.

LUBRICATION:

- Add lubricating oil to all moving parts as needed.

KNOW YOUR JACK

Compare these illustrations with your jack before operation and/or oil level maintenance to become familiar with the location of jack components.

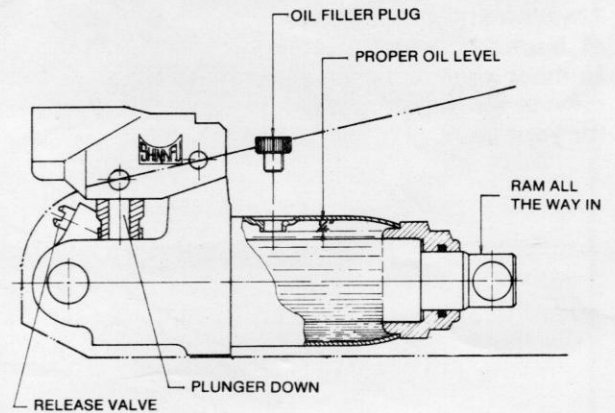

FIG. 2

PREVENTING RUST

- Check ram and pump plunger (see Fig. 2) every few months for any signs of rust or corrosion. Clean as needed and wipe with an oily cloth.
- When not in use, **ALWAYS** store jack with saddle and pump plunger lowered all the way down.

PROBLEM-SOLVING HINTS

POSSIBLE JACK PROBLEMS						POSSIBLE CAUSES AND SOLUTIONS (Refer to Operation and Maintenance procedures for detailed information)
Jack will not lift load	Jack will lift load, but will not hold	Jack will not lower completely	Poor jack lifting. Pump feels spongy	Jack will not lift to full height	Handle raises by itself when jack is under load	
X						Release valve not tightly closed. To close or tighten, turn release valve clockwise.
X			X	X	X	Air is in hydraulic system. Release air from system.
X	X		X	X		Oil level is low in jack. Add oil as required.
		X				1. Oil reservoir is over-filled. Drain out some oil. 2. Lubrication of moving parts is necessary.
X	X		X			Power unit is malfunctioning. Replace the power unit.

REPAIR PARTS

Sears 4500 Lbs. Capacity Service Jack
Model Number 214.50111

Model Number 214.50111

The Model Number and Serial Number will be found on the lifting arm. Always mention the Model Number and Serial Number when requesting service or repair parts for your Jack.

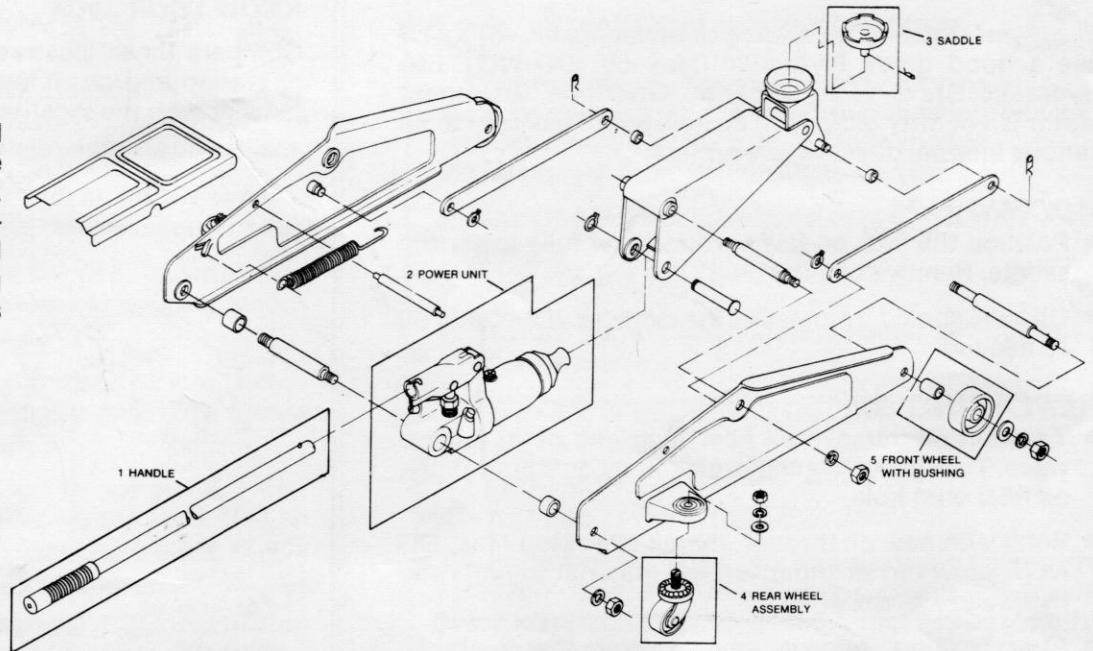

PARTS ARE ONLY AVAILABLE IN ASSEMBLIES (except Saddle)

Key	Parts No.	Description
1	3661	Jack handle
2	3662	Power unit assembly
3	3663	Saddle
4	3664	Rear wheel assembly
5	3665	Front wheel with bushing
—	3666	Owners manual

How to Order Repair Parts

All assemblies listed above may be ordered from any Sears Service Center and most Sears stores.

WHEN ORDERING REPAIR PARTS, ALWAYS GIVE THE FOLLOWING INFORMATION:

- REPAIR PART NUMBER
- REPAIR PART DESCRIPTION
- MODEL NUMBER 214.50111
- NAME OF ITEM: 4500 Lbs. Capacity Service Jack

IF THE PARTS YOU NEED ARE NOT STOCKED LOCALLY, YOUR ORDER WILL BE ELECTRONICALLY TRANSMITTED TO A SEARS REPAIR PARTS DISTRIBUTION CENTER FOR EXPEDITED HANDLING.

FULL ONE YEAR WARRANTY

If this service jack fails due to a defect in material or workmanship within one year from date of purchase, return it to the nearest Sears Store in the United States and Sears will replace it free of charge.

If this service jack is used for rental or commercial purposes, the warranty will apply for thirty days from date of purchase.

Warranty service is available by returning the complete unit to the nearest Sears store in the United States.

This warranty gives you specific legal rights. You may also have other rights which vary from state to state.

SEARS, ROEBUCK AND CO., Sears Tower, Department 731CR-W, Chicago, IL 60684.