



Description

Model MFJ15 service jack is a self-contained device designed for lifting, but not sustaining, a partial vehicular load. It consists of a frame with wheels and swivel casters supporting a mechanism that actuates a pivoting lift arm equipped with a saddle. It is designed for use by professional auto mechanics.

Before Use

IMPORTANT! BEFORE USING THIS JACK:

The breather located below hole in cross plate must be opened. Insert slotted screw driver through hole and turn breather screw counter clockwise until it stops turning. Do not force screw past stopping point.

Air may become trapped in the hydraulic system during transit.

To purge air:

1. Open release valve by turning handle counterclockwise.
2. Pump handle rapidly 4 full strokes. This will expel air that may have entered hydraulic fluid passages during transit.
3. Close release valve by rotating handle clockwise and pump handle.
4. If lift arm raises to full height, jack is ready for use. If not, repeat this procedure or follow trouble shooting instructions provided.

Inspection

Visual inspection should be made before each use of the jack, checking for leaking hydraulic fluid and damaged, loose or missing parts. Each jack must be inspected by a manufacturer's repair facility immediately, if subjected to an abnormal load or shock. Any jack which appears to be damaged in any way, is found to be badly worn, or operates abnormally **MUST BE REMOVED FROM SERVICE** until necessary repairs are made by a manufacturer's authorized repair facility. It is recommended that an annual inspection of the jack be made by a manufacturer's authorized repair facility and that any defective parts, decals or warning labels be replaced with manufacturer's specified parts. A list of authorized repair facilities is available from the manufacturer.

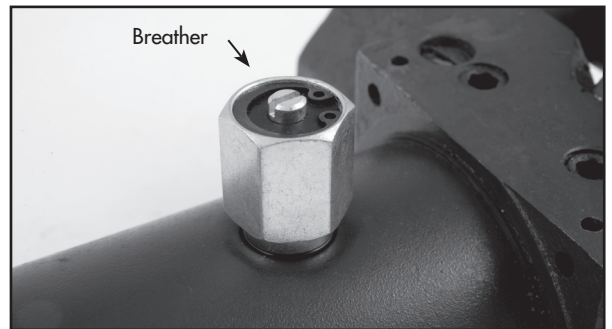

!WARNING

THIS IS A LIFTING DEVICE ONLY. DO NOT MOVE OR DOLLY THE VEHICLE WHILE ON THE JACK. IMMEDIATELY AFTER LIFTING SUPPORT THE VEHICLE WITH APPROPRIATE MEANS.

DO NOT OVERLOAD. OVERLOADING CAN CAUSE DAMAGE TO OR FAILURE OF THE JACK.

LIFT ONLY ON AREAS OF THE VEHICLE AS SPECIFIED BY THE VEHICLE MANUFACTURER.

CENTER LOAD ON SADDLE PRIOR TO LIFTING. OFF-CENTER LOADS MAY CAUSE DAMAGE TO JACK, LOSS OF LOAD, PROPERTY DAMAGE, PERSONAL OR FATAL INJURY.

THIS JACK IS DESIGNED FOR USE ONLY ON HARD LEVEL SURFACES CAPABLE OF SUSTAINING THE LOAD. USE ON OTHER THAN HARD LEVEL SURFACES CAN RESULT IN JACK INSTABILITY AND POSSIBLE LOSS OF LOAD.

NO ALTERATIONS TO THE JACK SHALL BE MADE.

READ, STUDY AND UNDERSTAND THE OPERATING MANUAL PACKED WITH THIS JACK BEFORE OPERATING.

FAILURE TO HEED THESE WARNINGS MAY RESULT IN LOSS OF LOAD, DAMAGE TO JACK, AND/OR FAILURE RESULTING IN PROPERTY DAMAGE, PERSONAL OR FATAL INJURY.

!WARNING

FOR YOUR SAFETY AND TO PREVENT INJURY:

Use Service Jack for lifting purposes **ONLY**.

Always support vehicle with jack stands.



1.5 Ton “LowJack” Service Jack

Operating Instructions

IMPORTANT: Before attempting to raise a vehicle, check vehicle service manual for recommended lifting surfaces.

1. To raise load: Close release valve tightly (by turning handle clockwise). **DO NOT OVERTIGHTEN.** Position jack under load so that saddle will contact load firmly and load is centered so it cannot slip. Operate jack handle until saddle approaches the load. Once again check to see that saddle is correctly positioned. Raise load to desired height. Place jack stands of appropriate capacity under the vehicle. **DO NOT CRAWL UNDER VEHICLE WHILE LIFTING VEHICLE OR PLACING OR REMOVING JACK STANDS!** Place jack stands at vehicle manufacturer's recommended lift areas that provide stable support for the raised vehicle.
2. To lower load: Open release valve **VERY SLOWLY** (by turning handle counterclockwise). When release valve is opened, saddle and load will be lowered. Lower the vehicle slowly so as not to shock load the jack stands. Once repairs are completed, raise vehicle enough to remove jack stands. Lower vehicle very slowly.

CAUTION: Keep hands or feet away from the hinge mechanism of the jack.

Maintenance

IMPORTANT: When adding or replacing hydraulic fluid, always use a quality hydraulic fluid. **DO NOT** use brake fluid, alcohol, glycerine, detergent motor oil, or dirty oil as improper fluid can cause serious internal damage to jack.

To add hydraulic fluid: With saddle fully lowered and jack on level ground, remove breather. The hydraulic fluid should just cover the surface of the internal cylinder visible through the hole. Do not overfill. Replace breather. If low, add hydraulic fluid as needed.

Maintenance and Inspection: The owner and/or user must maintain and inspect the jack in accordance with the manufacturer's instructions.

Lubrication

All moving joints require lubrication on a regular maintenance schedule. Remove handle and grease the lower end of handle where it rotates in the handle socket. Using a grease gun, grease the lift arm pivot shaft grease fitting until grease appears at the end of the shaft. Grease all lift arm linkages, front wheels and rear casters.

Owner/User Responsibility

The owner and/or user must have an understanding of the manufacturer's operating instructions and warnings before using this jack. Personnel involved in the use and operation of equipment shall be careful, competent, trained, and qualified in the safe operation of the equipment and its proper use when servicing motor vehicles and their components. Warning information should be emphasized and understood. If the operator is not fluent in English, the manufacturer's instructions and warning shall be read to and discussed with the operator in the operator's native language by the purchaser/owner, making sure that the operator comprehends its contents.

Owner and/or user must study and maintain for future reference the manufacturers' instructions. Owner and/or user is responsible for keeping all warning labels and instruction manuals legible and intact. Replacement labels and literature are available from the manufacturer.

1.5 Ton "LowJack" Service Jack

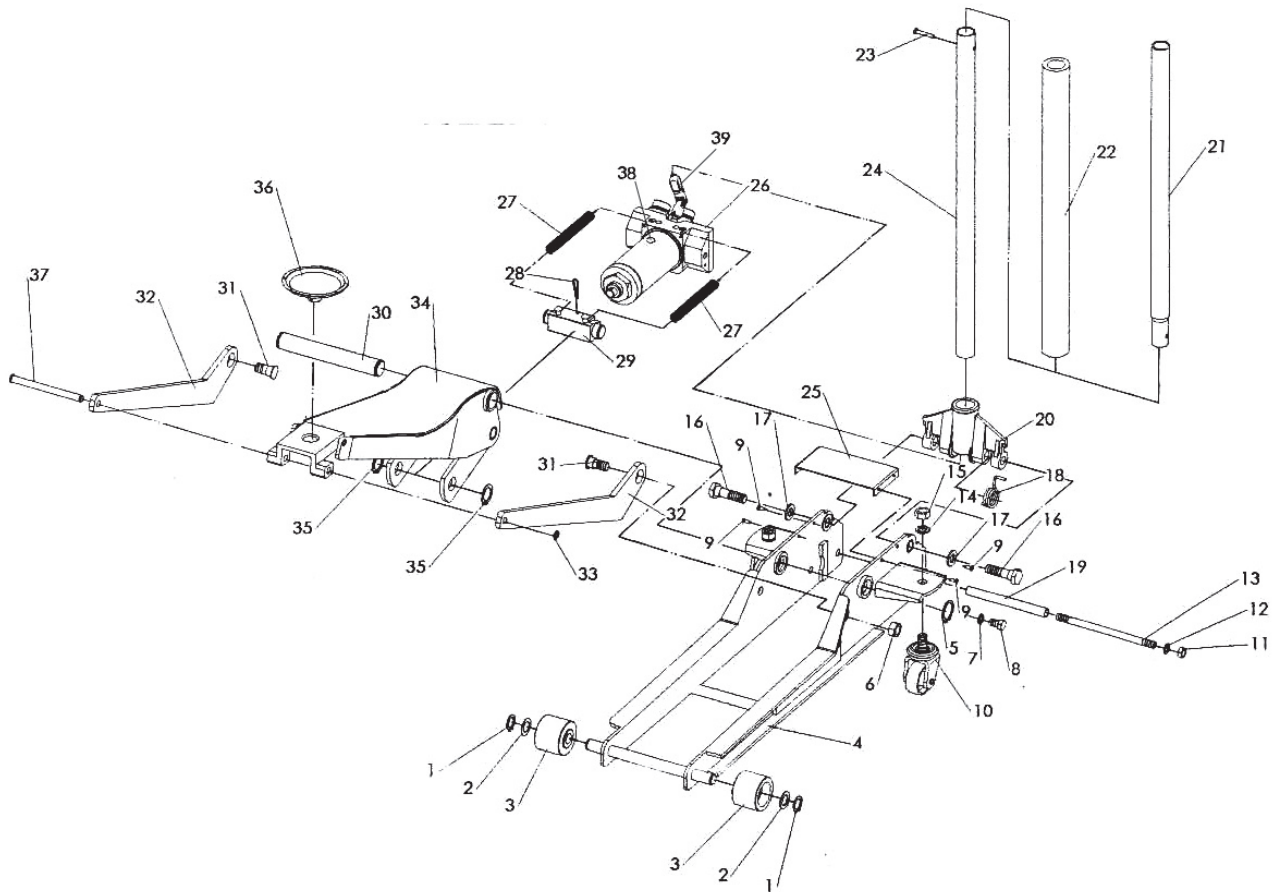

Index No.	Part No.	Description	Qty.
1	RS3501	Retaining Ring	2
2	RS3501-1	Washer	2
3	RS15T03	Wheel	2
4		Side Plate Assy.	1
5		Washer 24	2
6	RS3511	Hex Nut M16	2
7		Spring Washer	2
8	RS3516	Hex Bolt M12 x 20	2
9		Screws	4
10	RS15T10	Caster Assembly	2
11		Nut M8	2
12		Washer 8	2
13		Pull Rod	1
14		Spring Washer 18	2
15	RS3510N	Nut M18	2
16		Bolt	2
17		Spring Washer	2
18	RS3537	Torsion Spring	2
19		Pull Rod Sheath	1
20	RS15T20	Handle Socket	1

Index No.	Part No.	Description	Qty.
21	RS3536	Handle Upper	1
22	RS15T22	Handle Bumper	1
23	RS3534	Hex Bolt M6 x 35	1
24	RS3535	Handle Lower	1
25		Inspection Plate	1
26	RS15T26	Power Unit Ass'y	1
	RS15T26SK	Seal Kit for power unit	1
27		Spring	4
28		Split Pin 4 x 25 (incl. w/#29)	1
29	RS3520A	Block Linkage (incl. #28)	1
30		Shaft Arm	1
31		Bolt	2
32		Long Linkage	2
33		Retaining Ring	2
34		Lift Arm Assembly	1
35		Retaining Ring 25	2
36	RS15T36	Saddle	1
37		Linkage Axle	1
38	RS35BA	All Weather Breather	1
39	RS3530	Universal Joint Assembly	1

Only items identified by part number are available for purchase.

1.5 Ton “LowJack” Service Jack

Warranty Notice... Hydraulic Warranty Policy

Matco® shop equipment and tools, excluding accessories, are warranted against defects in materials or workmanship for a period of 1 year from original purchase. We will repair or replace at our option any defective part or unit which proves to be defective in material or workmanship within this warranty plan. This warranty does not cover damage to equipment or tools arising from alteration, abuse or misuse, and does not cover any repairs or replacement made by anyone other than Matco or its authorized service centers.

The foregoing obligation is Matco Tools sole liability under this or any implied warranty and under no circumstances shall we be liable for any incidental or consequential damages.

NOTE: Some states do not allow the exclusion or limitation of incidental or consequential damages, so the above limitation or exclusion may not apply to you.

Return equipment or parts to Matco Tools, or an authorized service center, transportation prepaid. Be certain to include your name and address, evidence of the purchase date, and description of the suspected defect.

If you have any questions about warranty service, please write to Matco Tools, Stow, OH 44224. This warranty gives you specific legal rights and you may also have other rights which vary from state to state.

PROBLEM					SOLUTION
Jack will not lift load or leaks down excessively	Jack will not lift to its full height	Jack will not lower completely	Jack will not lift smoothly or jack feels spongy	Jack will not hold load or handle rises	
✓					The release valve is not closed. Turn the valve clockwise tightly. If this does not work, remove handle, lubricate handle receptacle and handle end, then retry.
✓	✓				Low on hydraulic fluid. Refill the jack to the correct level of hydraulic fluid.
✓					Pump seals or back-up ring may be defective. Clean hydraulic fluid passages, replace seals and refill hydraulic fluid. (Must be serviced by qualified service center)
	✓		✓		The hydraulic system has trapped air. Open the release valve, pump handle rapidly (4) full strokes to purge air, close release valve.
		✓			Return spring is broken or linkages are binding. Replace spring if broken. Grease pivot shaft and all lift arm linkages.
				✓	Discharge ball is not sealing hydraulic system and oil may be dirty. Manually flush hydraulic system. Open the release valve, as required, to raise and lower the lift arm. Manually raise and lower lift arm.