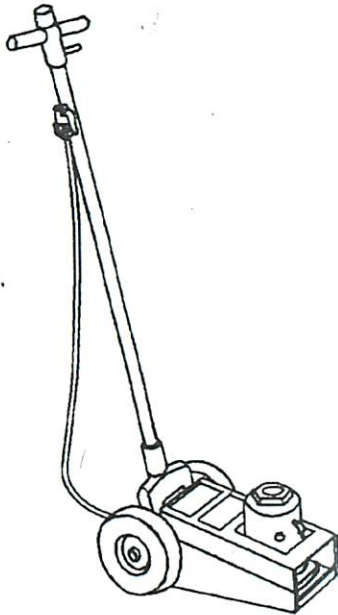

LINCOLN**TRI-CITY HYDRAULIC JACK SERVICE**4628 N. Florida Avenue
Tampa, Florida 33603-3700
(813) 236-8551**AIR OPERATED SERVICE JACK
MODEL 93733 (SERIES "A")****OWNER/OPERATOR MANUAL****SPECIFICATIONS**

CAPACITY	20 TON
LOW HEIGHT	9 IN.
HIGH HEIGHT WITH EXTENSION	19-3/4 IN.
SCREW EXTENSION	5 IN.
LIFT CAP DIAMETER	2 IN.
WHEEL DIAMETER	8 IN.
CHASSIS OVERALL LENGTH	20 IN.
WIDTH AT WHEELS	13-1/4 IN.
HANDLE HEIGHT	55 IN.
WEIGHT	89 LBS.
AIR PRESSURE (20 TON)	100 P.S.I.
TYPICAL OPERATING PRESSURE	125-150 P.S.I.
TYPICAL LIFT TIME - FULL RAISE (20 TON, 150 P.S.I.)	2 MIN. 15 SEC.

DESCRIPTION

Model 93733 is an air operated low (9 inch) pickup jack designed for truck and trailer emergency road service calls. The jack provides the following features:

- Operates with 100-150 P.S.I. air.
- Compact, portable, easy to transport and store.
- Long handle and low height for lifting loaded trailers and trucks under the axles.
- Automatic overload protection prevents overloading and exceeding the jack rated lifting capacity.
- Two speed lifting action to quickly contact a load then power raise it.
- Screw extension provides low pickup height adjustments.

OWNER/OPERATOR RESPONSIBILITY

It is the owner/operator responsibility to properly use and maintain this equipment.

The instructions and warnings contained in this manual shall be read and understood by the owner/operator prior to operating this equipment.

If an owner/operator does not understand English, the contents of this manual shall be explained in the owner/operator native language to assure the owner/operator comprehends.

It is the owner/operator responsibility to maintain the legibility of all warning and instruction labels. See the Repair Section of this manual for the replacement label kit.

The owner/operator shall retain this manual for future reference to important warnings, operating and maintenance instructions.

! WARNING

FAILURE TO HEED THE FOLLOWING INSTRUCTIONS MAY RESULT IN PERSONAL INJURY AND/OR PROPERTY DAMAGES

- Use only as a lifting device. Do not use to support a load or vehicle.
- Use jack on hard level surfaces.
- Center load on lift cap.
- Use vehicle stands or appropriate support after lifting vehicle/load.
- Lift only at locations specified by the manufacturer.
- Do not crawl under a vehicle/load when placing stands or support.
- Lower a vehicle slowly.

— USE VEHICLE STANDS —

One Lincoln Way
St. Louis, Missouri 63120-1578
Customer Service (314) 679-4300

Copyright 1994
Printed in USA

B61LW93733000A1

WARNING

**FOR YOUR
SAFETY**



**USE VEHICLE STANDS OR OTHER
APPROPRIATE SUPPORTS
TO SUPPORT THE VEHICLE /LOAD
BEFORE GETTING UNDER IT.**

ASSEMBLY

With the jack in its normal lifting position, remove the square head shipping plug at the front of the jack and attach the 1/4" air line with the elbow fitting.

INSPECTION

Prior to using and maintenance a visual inspection is recommended checking for hydraulic oil leakage and damaged or missing parts. Do not use if a problem is observed that could affect your safe use of the equipment. Contact your nearest service center for repairs before placing the jack back into service.

OPERATION

This jack is operated by air pressure which cycles a small reciprocating pump to raise the jack. In addition to cycling the pump, air pressure is also applied to the hydraulic oil reservoir by the small tube at the front of the jack. The air pressure above the hydraulic oil forces the oil into the ram cylinder providing the "rapid-raise" feature at the beginning of the lift until the chassis is contacted.

When the load is contacted, the pump takes over and power raises the vehicle. Insufficient air pressure will cause the pump to run slow and then "stall" short of attaining maximum rated lifting capacity of 20 tons. 100 P.S.I. air pressure is needed to lift 20 tons. Air pressure between 125 and 150 P.S.I. provides good operation. Pressure above 150 P.S.I. will affect the durability of the pump and related oil seals. If the air pump can be heard cycling but the jack does not lift, the hydraulic circuit may be "air bound". Refer to AIR PURGING procedure in the TROUBLESHOOTING section of this manual.

USING JACK

1. Set vehicle parking brakes and/or block vehicle wheels.
2. Open release valve by turning release knob counterclockwise and allow jack to fully retract.
3. Connect air hose to jack. 100-150 P.S.I. is required for rated lifting capacity (40,000 lbs.).
4. Position jack under desired vehicle lifting point suggested by manufacturer.
5. Firmly close release valve by turning release knob clockwise.
6. The jack lift cap must contact the vehicle lift surface squarely and as close to center of lift cap as possible.
7. Press air control valve lever and raise vehicle to desired height. DO NOT lift vehicle any higher than is needed to make repairs.
8. DO NOT crawl under vehicle while positioning vehicle stands.
9. Slowly turn release knob counterclockwise to open release valve and carefully lower vehicle on to vehicle stands or other appropriate supports.

REMOVING JACK

1. Make sure release valve is closed by firmly turning release knob clockwise.
2. Press air control valve and raise vehicle just enough to clear vehicle stands or support means.
3. Remove vehicle stands or other support means from under vehicle. DO NOT crawl under vehicle when removing vehicle stands.
4. Slowly turn release knob counterclockwise to open release valve and lower vehicle.
5. When vehicle is fully lowered, remove jack from under vehicle.

TROUBLESHOOTING

If the following procedures do not correct the problem, contact your nearest factory authorized service center. When submitting a jack or equipment to be repaired, be sure to state the nature of the problem and indicate if a repair cost estimate is required.

AIR PURGING

As with any hydraulic unit, the jack may occasionally become air bound due to being tipped over during handling or shipping. To remove air from the hydraulic circuits, open the release valve on the end of the handle by turning it counter clockwise about one turn. Cycle the jack in its normal upright position for 10 to 15 seconds. Press the ram "in" and check for normal lifting rate under load. If it doesn't seem normal, repeat the air purging procedure.

PROBLEMS

OIL LEAKAGE AROUND PUMP.

1. If the jack was tipped over on its side, jack oil in the reservoir could flow up the air line tube in the front of the jack and into the pumps/filter. The oil will blow out of the pump when the pump is first cycled. Pour any oil out of the filter bowl. Operating the jack under a load will cycle the pump and blow out the excess oil on the lines and pump. Wipe off the oil and the jack should operate normally.

2. The same problem could occur if excess oil is carried over from the compressor or an air line lubricator is not working properly. Any oil entering the air line at the jack control valve will blow out slowly through the pumps exhaust ports. The pump requires a small amount of lubrication (few drops) but excess oil will make the jack appear it is leaking oil.

JACK LIFTS SLOWER THAN NORMAL

1. The lifting speed is determined by the air pressure and air flow available to the jack at the jacks control valve. First check the brass screen in the control valve to make sure it isn't clogged with dirt and rust. Next check the available air pressure. It takes 100

P.S.I. to lift 20 tons. The higher the pressure (limit to 150 P.S.I.), the faster the jack will operate. Finally, the size (inner diameter) and the length of the hose to the jack make a difference. A long hose requires a larger I.D. to get adequate air flow to the jack. If the jack pumps slowly, a larger hose could correct the problem.

2. Clean air filter element located under the chassis cover. A clogged filter will restrict air flow. See **CLEANING FILTERS** in **MAINTENANCE** section of this manual.

3. Pump air motor may need lubrication. Check the air line lubricator for oil and proper operation if used. If not, squirt a few drops of light engine oil in the control valve inlet. Cycle the pump slowly to work the oil down into the pump.

JACK WILL NOT LIFT LOAD.

1. Air pressure may be too low. 100 P.S.I. required for 20 tons.
2. Release valve may not be completely closed and leaking.

JACK WILL NOT LIFT TO FULL HEIGHT.

Check oil level. See **CHECKING OIL LEVEL** in the **MAINTENANCE** section of this manual.

JACK WILL NOT LOWER.

Release valve linkage disconnected or broken. Valve stem will not rotate when knob is turned.

MAINTENANCE

CHECKING OIL LEVEL

1. Disconnect compressor/shop air hose from the control valve.
2. Press control valve lever to assure no air pressure is in jack.



3. With the jack in its upright operational position and the ram pushed in, remove the hex head filler plug located on the right side of the reservoir.

4. Add clean hydraulic jack oil until level comes up to the bottom edge of the filler hole.



5. Reinstall filler hole plug.

LUBRICATION

1. Use any grade engine oil to lubricate the wheel axles, U-joint and handle yoke pins.

CLEANING FILTERS

1. **CONTROL VALVE INLET.** Remove brass screen with pointed tool and clean out rust and dirt. Always reinstall it correctly otherwise rust and dirt will get into the jack and clog up air passages.

2. **FILTER WATER SEPARATOR BOWL.** Remove the chassis cover and unscrew the plastic filter bowl. Clean the bowl with soap and water. Do not use solvents. Solvents will damage and crack the bowl. Wash filter element in alcohol and blow out with compressed air.

REPAIR

Repair is limited to replacement of listed service parts. Special procedures and tools are required.

Service and repair parts are only available through factory authorized service centers. The Model Number and Series Letter is required for replacement part inquiries. For the service center nearest you, contact:

Lincoln Customer Service
One Lincoln Way
St. Louis, MO 63120-1578
(314) 679-4300

LIMITED WARRANTY

Lincoln, a division of McNeil (Ohio) Corp., a subsidiary of Pentair, Inc., warrants that jacks and related service equipment manufactured by it will be free from defects in material and workmanship during the one (1) year following the date of purchase. This warranty is extended to the original retailer purchaser only. If a jack or related service equipment proves to be defective during this warranty period, it will be repaired or replaced without charge. To obtain repair or replacement, it must be shipped, transportation charges prepaid, with proof of date of purchase, to a Lincoln authorized Warranty and Service Center, within the one (1) year following the date of purchase. This warranty does not apply to parts damaged from accident, overload, or abuse, nor does it apply to any equipment which has been altered or used with special attachments other than those recommended by Lincoln. No other express warranty applies to jacks and related service equipment manufactured by Lincoln.

ANY IMPLIED WARRANTIES applicable to jacks and related service equipment manufactured by Lincoln, INCLUDING THE WARRANTIES OF MERCHANTABILITY AND FITNESS FOR A PARTICULAR PURPOSE, WILL LAST ONLY FOR ONE (1) YEAR FROM THE DATE OF PURCHASE. SOME STATES DO NOT ALLOW LIMITATIONS ON HOW LONG AN IMPLIED WARRANTY LASTS SO THE ABOVE LIMITATION MAY NOT APPLY TO YOU.

In no event shall Lincoln be liable for incidental or consequential damages. The liability of Lincoln on any claim or damage arising out of the sale, resale, or use of a jack or related service equipment shall in no event exceed the purchase price. SOME STATES DO NOT ALLOW THE EXCLUSION OR LIMITATION OF INCIDENTAL OR CONSEQUENTIAL DAMAGES, SO THE ABOVE LIMITATION OR EXCLUSION MAY NOT APPLY TO YOU.

THIS WARRANTY GIVES YOU SPECIFIC LEGAL RIGHTS, AND YOU MAY ALSO HAVE OTHER RIGHTS WHICH VARY FROM STATE TO STATE.

4628 N. Florida Avenue
Tampa, Florida 33603-3700
(813) 236-8551

SERVICE PARTS

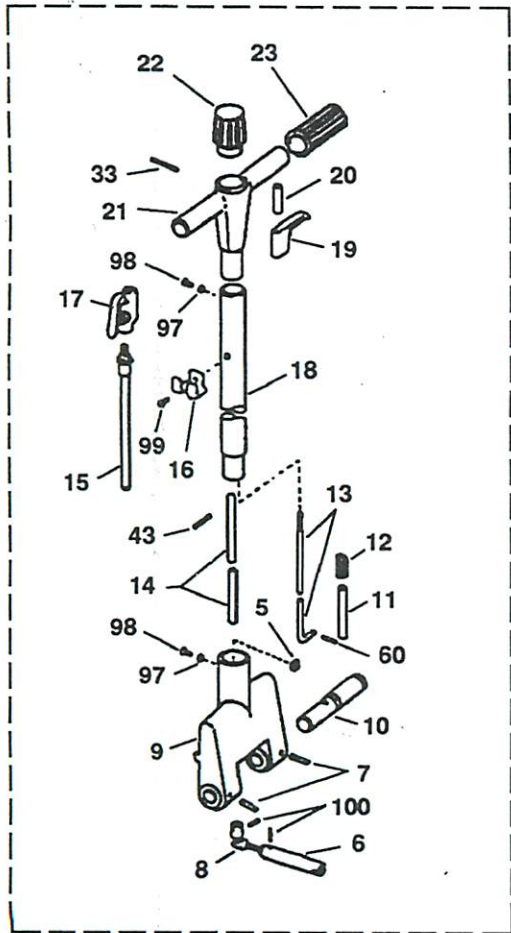
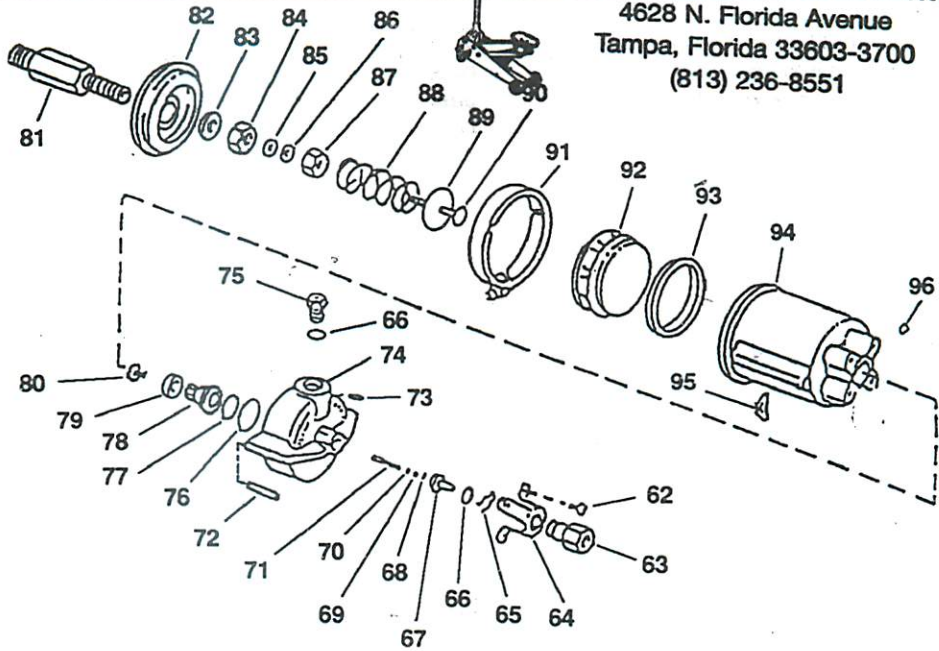
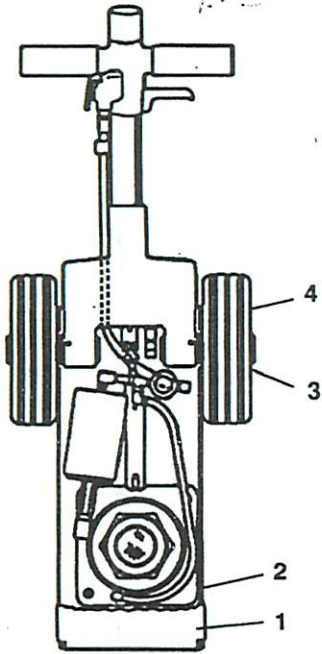

101 - HANDLE ASSEMBLY
(LESS ITEMS 10, 15, 16 AND 17)

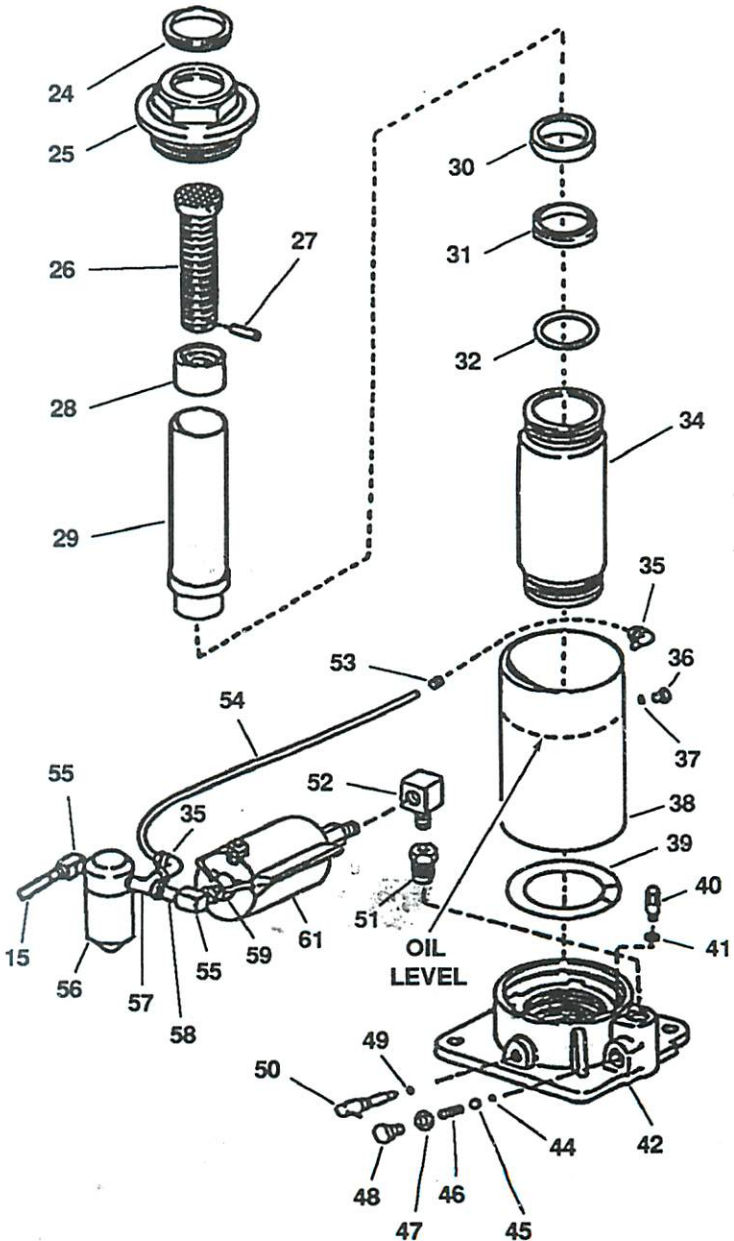

OIL LEVEL

SERVICE PARTS (CONT)

ITEM	PART NO.	DESCRIPTION	QTY	ITEM	PART NO.	DESCRIPTION	QTY
1.	BK210980	Top cover	1	56.	BJ792018	Filter assy. (complete)	1
2.	BJ511626	Frame	1	57.	BK264096	Tee	1
3.	BB557523	Retaining ring	4	58.	BJ790096	Nipple	1
4.	BE587106	Wheel	2	59.	BJ788039	Bushing	1
5.	SJ100420	Nut	1	60.	AJ100032	Cotter pin	1
6.	BK901038	Release valve adaptor	1	61.	BK210950	Air motor assembly	1
7.	BA812261	Handle pin	2	62.	BCR50028	Screw	4
8.	BJ396900	Universal joint	1	63.	BCH80340	Coupler	1
9.	BA707133	Yoke	1	64.	BCH49098	Retaining cover	1
10.	BJ395104	Axle	2	65.	BCH50044	Retaining ring	1
11.	BA766061	Segment pin	1	66. ●	B1220503	O-ring	2
12.	BA768141	Segment spring	1	67. ●	BCH34808	Grommet	1
13.	BA961142	Segment pin rod	1	68.	CB256018	Filter	1
14.	BK110400	Release rod	1	69.	BCH79039	Bushing	1
15.	BJ354646	Air hose	1	70. ●	B1001503	O-Ring	1
16.	BK59110	Air valve bracket	1	71.	BCH45040	Plunger	1
17.	35100007	Air valve	1	72.	B7000381	Tubing	1
18.	17000003	Handle tube	1	73.	B1040057	Spring pin	2
19.	BA963144	Segment lever	1	74.	CR500098	Cover	1
20.	BD894055	Segment rod nut	1	75.	CB116006	Plug	1
21.	BA962135	Cross handle	1	76. ●	BK898041	O-ring	1
22.	BK130800	Release knob	1	77. ●	CM322041	Quad ring	1
23.	BA725550	Handle grip	2	78.	CB121051	Piston	1
24. ■	NJ100046	Quad ring	1	79.	CB644108	Back-up washer	1
25.	BJ398020	Top cap	1	80.	CF157028	Pan head screw	1
26.	BJ382028	Adj. screw	1	81.	BK520400	Plunger body	1
27.	BD674061	Pin	1	82.	BK261101	Plate	1
28.	BJ385446	Plunger sleeve	1	83.	BK361080	Lockwasher	1
29.	21100488	Plunger	1	84.	BK350550	Hex nut	1
30. ■	36400011	Bearing	1	85. ●	CB918041	U-cup	1
31. ■	248428	U-cup	1	86.	BK110390	Back-up bushing	1
32. ■	30600031	Retaining ring	1	87.	BK340550	Hex gland nut	1
33.	BA954058	Pin	1	88.	CH210110	Spring	1
34.	BJ390030	Cylinder	1	89.	BK110800	Spring cap	1
35.	BJ990096	Male elbow	2	90.	CB180040	Plunger	1
36. ■	AJ100060	Filler plug	1	91.	CB219044	Body retainer	1
37. ■	AJ100020	Filler plug gasket	1	92.	CB109051	Piston	1
38.	BJ389025	Reservoir	1	93. ●	CB808041	U-cup	1
39.	BK810800	Washer	1	94.	13000007	Cylinder	1
40.	BK876900	Relief valve	1	95. ●	CB919041	Seal	1
41.	BS303700	Washer	1	96. ●	B1004503	O-ring	1
42.	BK55005P	Base w/plug	1	97.	BD914108	Washer	4
43.	BD184061	Pin	1	98.	BA953252	Screw	4
44. ■	B1160000	Ball 7/32" dia.	1	99.	SJ100374	Screw	1
45. ■	BS116000	Ball 5/16" dia.	1	100.	BD374061	Pin	2
46. ■	AJ100040	Valve spring	1	101.	BK216950	Handle assembly	1
47. ■	AJ100039	Valve plug gasket	1				
48. ■	BK300600	Valve plug	1	-	245392	Label Kit	-
49. ■	AJ100312	Release valve O-ring	1	-	B67415X1	Hydraulic Jack	-
50.	BK490010	Release spindle	1			Repair Kit	
51.	BJ580096	Pump nipple	1		81735002	Air pump	-
52.	BK729100	Elbow	1			Repair Kit	
53.	BK102700	Ferrule	2				
54.	BK964600	Tube	1				
55.	BJ479096	Street elbow	2				

■ Included in Hydraulic Jack Repair Kit B67415X1.
● Included in Air Pump Repair Kit 81735002.



TRI-CITY HYDRAULIC JACK SERVICE

4628 N. Florida Avenue
Tampa, Florida 33603-3700
(813) 236-8551

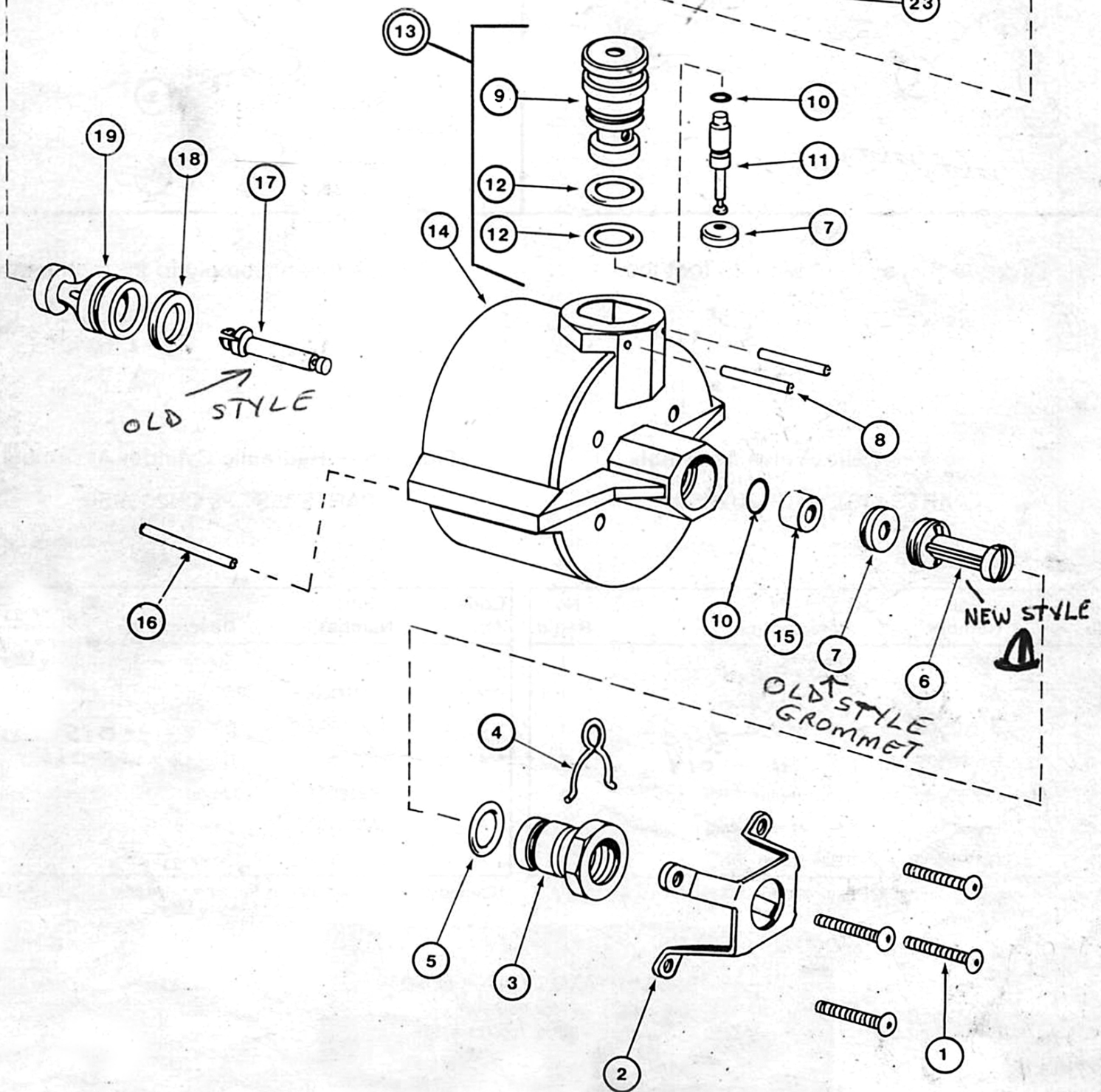
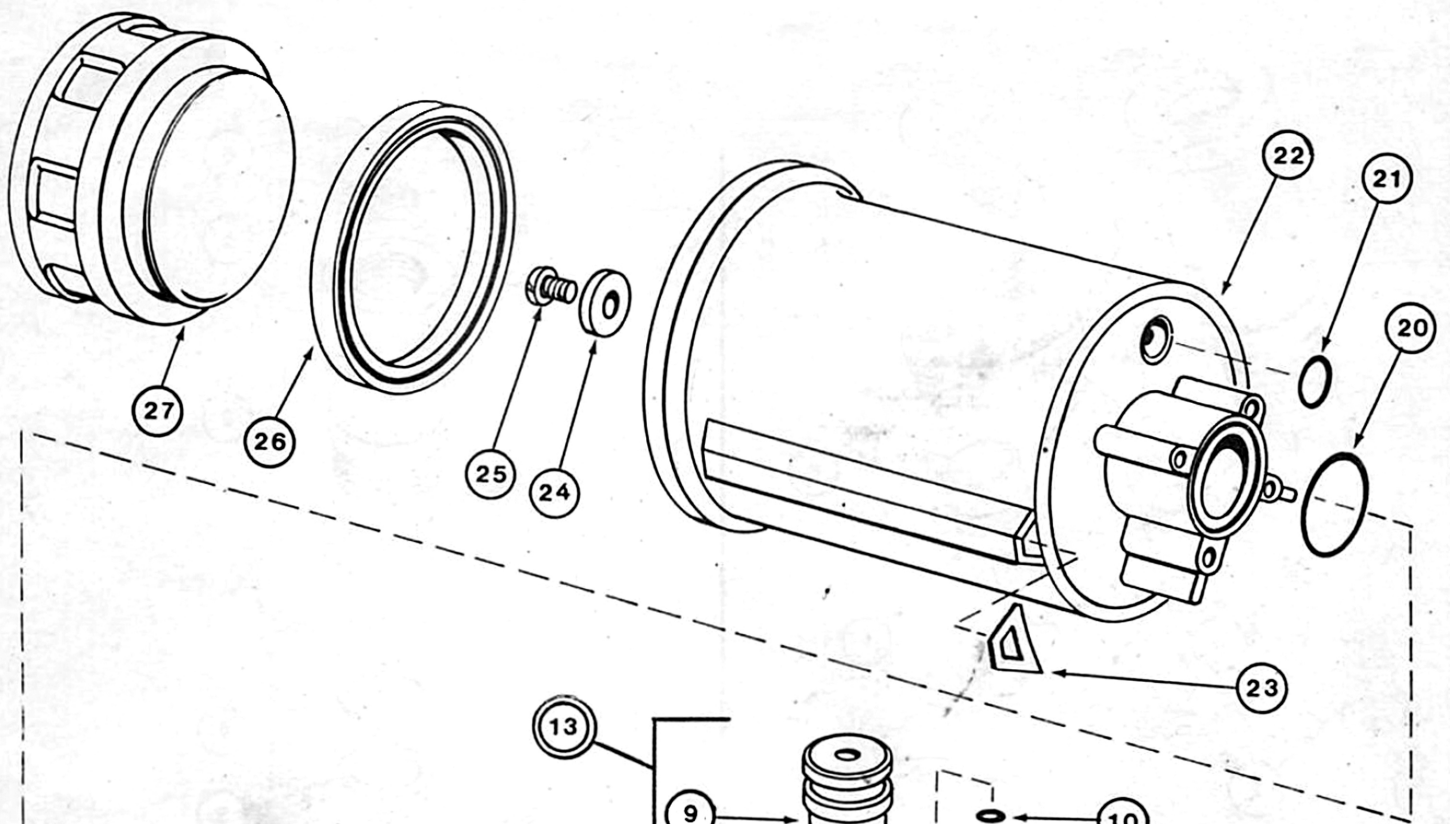

Code No.	Part Number	Description	No. Req'd
1	CR50028	Button Head Cap Screw	4
2	CH49098	Retaining Cover	1
3	CL163950	Coupler w/"O" Ring	1
4	CH50044	Retaining Clip	1
* 5	B1220503	"O" Ring	1
6	CB256018	Filter - (NEW STYLE DA 5015118SR)	1
* 7	CH34808	Grommet - NEW STYLE GROMMET WITH PLUNGER KIT # BCH45040	2
8	B1040057	Spring Pin	1
9	CB502013	Poppet Guide	1
*10	B1001503	"O" Ring	2
11	CB253051	Poppet Piston	1
*12	B1220503	"O" Ring	2
13	CK352950	Poppet Guide Assembly	1
14	CR500098	Cover	1
15	CH79039	Bushing	1
16	CA1204268	Tube	1
17	CH45040	Plastic Poppet Plunger - KIT # BCH45040 NEW STYLE WITH NEW STYLE GROMMET	1
18	CM322041	Quad Ring	1
19	CB121051	Plastic Piston	1
*20	B1228503	"O" Ring	1
*21	B1004503	"O" Ring	1
22	CR499030	Cylinder	1
*23	CB919041	Cover Seal	1
24	CB644108	Backup Seal	1
25	CF157028	Pan Head Screw	1
*26	CB808041	U-Cup	1
27	CB109051	Plastic Piston	1

*Starred items are included in Repair Kit 65426X.