

JohnDow 
Industries

**Professional
Lift
Equipment**

Pump To Load Service Jack

Owner's Manual

**Model
SJ-25QL**

**Capacity
2-1/2 Ton**

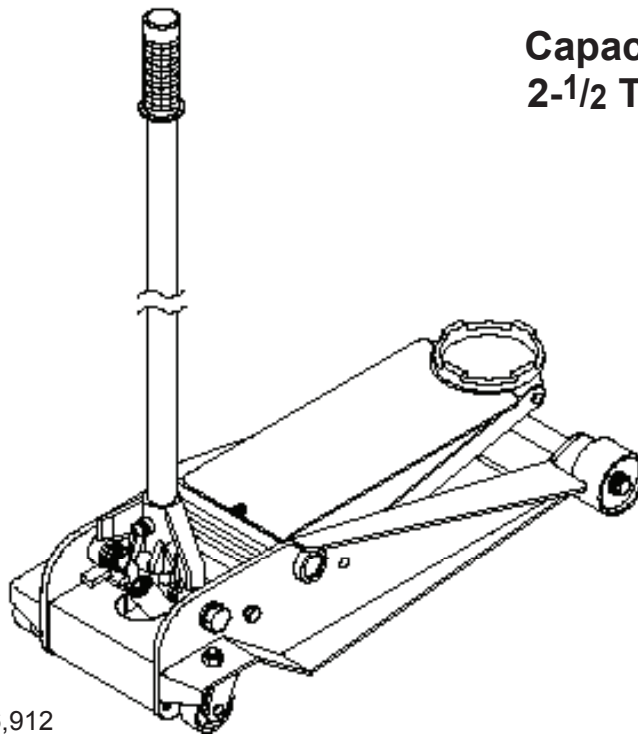

U.S. Patent No's. 5,755,099 • 5,946,912



This is the safety alert symbol. It is used to alert you to potential personal injury hazards. Obey all safety messages that follow this symbol to avoid possible injury or death.

ADVERTENCIA

- Leer, comprender, y seguir las instrucciones antes de utilizar el aparato.
- El manual de instrucciones y la información de seguridad deben estar comunicados en lengua del operador antes del uso.
- No seguir estas indicaciones puede causar daños personales o materiales.

WARNING

To avoid **crushing and related injuries**:



- **NEVER** work on, under or around a load supported only by a hydraulic jack.
- **ALWAYS** use adequately rated jack stands.

Read this manual and follow all the Safety Rules and Operating Instructions before using this product.

SAFETY and GENERAL INFORMATION

Save these instructions. For your safety, read, understand, and follow the information provided with and on this jack before using. The owner and operator of this equipment shall have an understanding of this jack and safe operating procedures before attempting to use it. The owner and operator shall be aware that use and repair of this product may require special skills and knowledge. Instructions and safety information shall be conveyed in the operator's native language before use of this jack is authorized. If any doubt exists as to the safe and proper use of this jack, remove from service immediately.

Inspect before each use. Do not use if broken, bent, cracked or damaged parts are noted. Any jack that appears damaged in any way, or operates abnormally shall be removed from service immediately. If the jack has been or suspected to have been subjected to a shock load (a load dropped suddenly, unexpectedly upon it), immediately discontinue use until jack has been checked by a factory authorized service center (contact distributor or manufacturer for list of authorized service centers). It is recommended that an annual inspection be done by qualified personnel. Labels and Operator's Manuals are available from the manufacturer.

PRODUCT DESCRIPTION

This Service Jack is designed to lift, but not support, one end of a vehicle. Immediately after lifting, loads must be supported by a pair of appropriately rated jack stands. This service jack has a unique feature that provides fast, no load lifts to the jacking point, at which time it lifts in approximately 0.75~0.2" increments.

NEVER use a hydraulic jack as a stand-alone device. After lifting, **immediately** support the lifted vehicle with a pair of appropriately rated jack stands. **NEVER** place **any** portion of your body beneath the vehicle when lifting **OR** lowering!

PREPARATION

Assembly

1. Assemble the 2-piece handle with provided bolt.
2. Insert handle into the handle sleeve. Tighten the bolt on handle sleeve to prevent accidental removal of handle while in use.

Before Use

1. Verify that the product and application are compatible, if in doubt call Tech Service (888) 332-6419.
2. Before using this product, read the operator's manual completely and familiarize yourself thoroughly with the product, its components and recognize the hazards associated with its use.
3. To familiarize yourself with basic operation, locate and turn the release valve (handle):
 - a. Clockwise until firm resistance is felt to further turning. This is the '**CLOSED**' release valve position used to **raise** the saddle.
 - b. Counter-clockwise, but no more than 1 turn from the closed position. This is the '**OPEN**' release valve position used to **lower** the saddle.
4. With saddle fully lowered, remove the vent screw. Pump 6 to 8 full strokes. This will help release any pressurized air which may be trapped within the reservoir. Check oil level (refer to Maintenance, page 4). Reinstall vent screw.
5. Ensure that jack rolls freely. Raise and lower the unloaded saddle throughout the lifting range before putting into service to ensure the pump operates smoothly. Replace worn or damaged parts and assemblies with authorized replacement parts only.

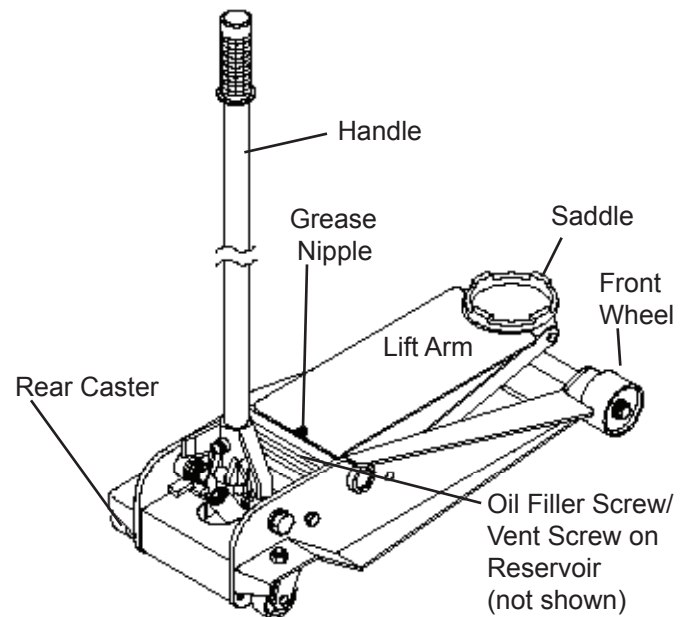

Figure 1 - Model SJ-25QL Components

SPECIFICATIONS

Model	Capacity	Jack Size (L x W x H)	Min. Height	Max. Height	Saddle Dia.
SJ-25QL	2-1/2 Ton	29-3/4" x 13-1/4"	4"	20"	5-1/2"

WARNING

- **Study, understand, and follow** all printed materials provided with/on this product **before use**.
- **Do not** exceed rated capacity.
- Use **only** on hard, level surface.
- **This is a lifting device only!**
- **Immediately** after lifting, support the load with a **pair** of appropriately rated jack stands.
- Lift **only** on areas of the vehicle as specified by the vehicle manufacturer.
- **Do not** move or **dolly** the **vehicle** while on the jack.
- No alterations shall be made to this product.
- **Failure to heed** these markings may **result in personal injury and/or property damage**.

OPERATION

Lifting

 *Only attachments and/or adapters supplied by the manufacturer shall be used. Lift only on area of the vehicle as specified by the vehicle manufacturer.*

1. Follow the vehicle manufacturer's recommended guidelines for lifting. Engage the emergency brake and chock each unlifted wheel in both directions to prevent inadvertent vehicle movement.
2. Close the release valve by turning the handle knob clockwise until firm resistance is felt.
3. Refer to the vehicle manufacturer owner's manual to locate approved lifting points on the vehicle. Center jack saddle under lift point.
4. Verify lift point, then pump handle to contact lift point. To lift, pump handle until load reaches desired height.
5. Transfer the load **immediately** to a pair of appropriately rated jack stands.

WARNING



To avoid **crushing and related injuries**:

- **Never** work on, under or around a load supported only by hydraulic jack.
- **Always** use adequately rated jack stands.
- Chock each unlifted tire in both directions.
- **Do not** use this device to lift, level, lower, support nor move a house, mobile home, travel trailer, camper or any building structure.
- **Be alert** and **sober** when using this product. Do not operate under the influence of drugs or alcohol.

 **NEVER** use hydraulic jack as a stand alone device! **ALWAYS** transfer the lifted load **IMMEDIATELY** to a pair of appropriately rated jack stands. **NEVER** place any portion of your body beneath the vehicle when lifting or lowering!

Lowering

1. Raise load high enough to clear the jack stands.
2. Remove jack stands carefully (**always** used in pairs).
3. **Slowly** turn the handle knob counter-clockwise, but no more than 1 full turn. If the load fails to lower:
 - a. Use another jack to raise the vehicle high enough to reinstall jack stands.
 - b. Remove the malfunctioning jack and then the jack stands.
 - c. Using the functioning jack to lower the vehicle.
4. After removing jack from under the vehicle, fully lower the saddle to reduce ram exposure to rust and contamination.

MAINTENANCE

Important: Use only good grade hydraulic jack oil. Avoid mixing different types of fluid and NEVER use brake fluid, turbine oil, transmission fluid, motor oil or glycerin. Improper fluid can cause premature failure of the jack and the potential for sudden and immediate loss of load. We recommend Mobil DTE 13M or equivalent.

Adding oil

1. With saddle fully lowered set jack in its upright, level position. Remove vent screw.
2. Fill with oil until ~3/16" above the inner cylinder as seen from the oil filler hole. Reinstall vent screw.

Changing oil

For best performance and longest life, replace the complete fluid supply at least once per year.

1. With saddle fully lowered, remove vent screw.
2. Lay the jack on its side and drain the fluid into a suitable container.

Note. Dispose of hydraulic fluid in accordance with local regulations.

3. Fill with oil until ~3/16" above the inner cylinder as seen from the oil filler hole. Reinstall vent screw.

Lubrication

A periodic coating of light lubricating oil to pivot points, axles and hinges will help to prevent rust and assure that wheels, casters and pump assemblies move freely.

Cleaning

Periodically check the pump piston and ram for signs of rust or corrosion. Clean as needed and wipe with an oily cloth.

Note: Never use sandpaper or abrasive material on these surfaces!

Storage

When not in use, store the jack with saddle fully lowered.



Paint contains lead!

DO NOT sand or grind painted surface!

TROUBLESHOOTING

Symptom	Possible Causes	Corrective Action
Jack will not lift load	<ul style="list-style-type: none"> • Release valve not tightly closed • Load is too heavy 	<ul style="list-style-type: none"> • Ensure release valve tightly closed • Consider higher capacity jack
Jack will lift, but not maintain pressure	<ul style="list-style-type: none"> • Release valve not tightly closed • Hydraulic unit malfunction 	<ul style="list-style-type: none"> • Ensure release valve tightly closed • Discontinue use, contact technical service
Jack will not lower after unloading	<ul style="list-style-type: none"> • Reservoir overfilled • Linkages binding 	<ul style="list-style-type: none"> • Drain fluid to proper level • Clean and lubricate moving parts
Poor lift performance	<ul style="list-style-type: none"> • Fluid level low • Hydraulic unit malfunction 	<ul style="list-style-type: none"> • Ensure proper fluid level • Discontinue use, contact technical service
Will not lift to full extension	<ul style="list-style-type: none"> • Fluid level low 	<ul style="list-style-type: none"> • Ensure proper fluid level

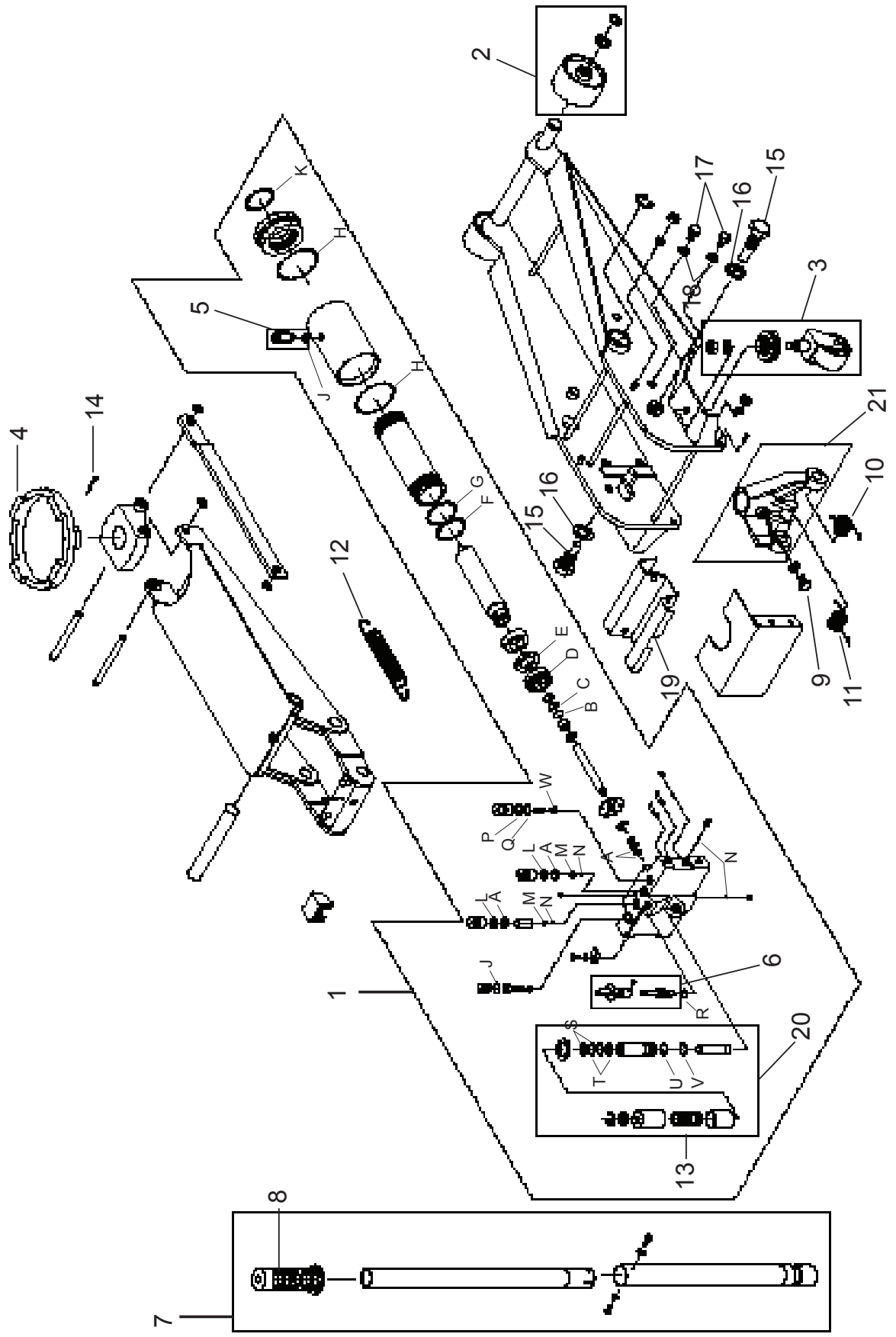

REPLACEMENT PARTS

(refer to page 5 & 6)

Not all components of the jack are replacement items, but are illustrated as a convenient reference of location and position in the assembly sequence. When ordering parts, please give the Model number, part number and parts description. Call or write for current pricing: SFA Companies 10939 N. Pomona Ave. Kansas City, MO 64153, U.S.A. CustomerService@johndow.com Tel: (888) 332-6419 Fax: (816) 891-6599

Replacement Parts for models SJ-25QL:

Item	Part No.	Description	Qty
1	G610-11000-000	Hydraulic Power Unit	1
2	G640-90010-K02	Front Wheel Assy.	2
3	G610-90009-K03	Rear Caster Assy.	2
4	G610-00016-000	Saddle	1
5	G62S-03300-200	Vent Screw Assy.	1
6	G610-90009-K06	U-joint Assy.	1
7	G610-90009-K01	Handle (2 pc.)	1
8	G933-0001-000	Handle Grip	1
9	5102-08016-000	Bolt, M8x16	1
10	G931-00009-000	Spring, Handle Sleeve (Right)	1
11	G610-00008-000	Spring, Handle Sleeve (Left)	1
12	G931-00003-000	Spring, Lift Arm	2
13	G610-03005-000	Spring, Pump	1
14	5404-04040-000	Retainer, 4x40	1
15	G610-00009-000	Handle Bolt	2
16	5303-00020-000	Lock Washer, M20	2
17	G931-00010-000	Bolt, M12	4
18	5303-00012-000	Lock Washer, M12	4
19	G610-00013-000	Cover	1
20	G610-90009-K02	Pump Piston Assembly	1
21	G610-06000-000	Handle Fork	1
**	G6900S-113	Repair Kit	-

Repair Kit Contents

Item	Description	Qty
A	O-ring, D7.8x2.65	4
B	Back-up Ring	1
C	O-ring, D15x2.65	1
D	U-cup	1
E	Back-up Ring	1
F	O-ring, D44.5x2.4	1
G	Back-up Ring	1
H	O-ring, D63x2.65	2
J	O-ring, D8.2x2.4	2
K	O-ring, D31.6x3.5	1
L	Back-up Ring	2
M	Steel Ball, D9.52	2
N	Steel Ball, D6.35	5
P	Back-up Ring	1
Q	O-ring, D6x3	1
R	O-ring, D7.2x2.65	1
S	Back-up Ring	2
T	O-ring, D17.6x2.5	2
U	Back-up Ring	1
V	O-ring, D25x2.65	1
W	Steel Ball, D6.74	1
(in #5)	O-ring, D8.8x1.9	1

** Replacement requires special skills, knowledge, and equipment. Only authorized service center may perform the repair and/or replacement of these items.

ONE YEAR LIMITED WARRANTY

For a period of one (1) year from date of purchase, SFA Companies will repair or replace, at its option, without charge, any of its products which fails due to a defect in material or workmanship under normal usage. This limited warranty is a consumer's exclusive remedy.

Performance of any obligation under this warranty may be obtained by returning the warranted product, freight prepaid, to SFA Companies Warranty Service Department, 10939 N. Pomona Ave., Kansas City, MO 64153.

Except where such limitations and exclusions are specifically prohibited by applicable law, (1) THE CONSUMER'S SOLE AND EXCLUSIVE REMEDY SHALL BE THE REPAIR OR REPLACEMENT OF DEFECTIVE PRODUCTS AS DESCRIBED ABOVE. (2) John Dow SHALL NOT BE LIABLE FOR ANY CONSEQUENTIAL OR INCIDENTAL DAMAGE OR LOSS WHATSOEVER. (3) ANY IMPLIED WARRANTIES, INCLUDING WITHOUT LIMITATION THE IMPLIED WARRANTIES OF MERCHANTABILITY AND FITNESS FOR A PARTICULAR PURPOSE, SHALL BE LIMITED TO ONE YEAR, OTHERWISE THE REPAIR, REPLACEMENT OR REFUND AS PROVIDED UNDER THIS EXPRESS LIMITED WARRANTY IS THE EXCLUSIVE REMEDY OF THE CONSUMER, AND IS PROVIDED IN LIEU OF ALL OTHER WARRANTIES, EXPRESS OR IMPLIED. (4) ANY MODIFICATION, ALTERATION, ABUSE, UNAUTHORIZED SERVICE OR ORNAMENTAL DESIGN VOIDS THIS WARRANTY AND IS NOT COVERED BY THIS WARRANTY.

Some states do not allow limitations on how long an implied warranty lasts, so the above limitation may not apply to you. Some states do not allow the exclusion or limitation of incidental or consequential damages, so the above limitation or exclusion may not apply to you. This warranty gives you specific legal rights, and you may also have other rights, which vary from state to state.



SFA Companies
10939 N. Pomona Ave. Kansas City, MO 64153
888-332-6419
CustomerService@johndow.com

