

Master Copy



ENERPAC

Repair Parts

P-70

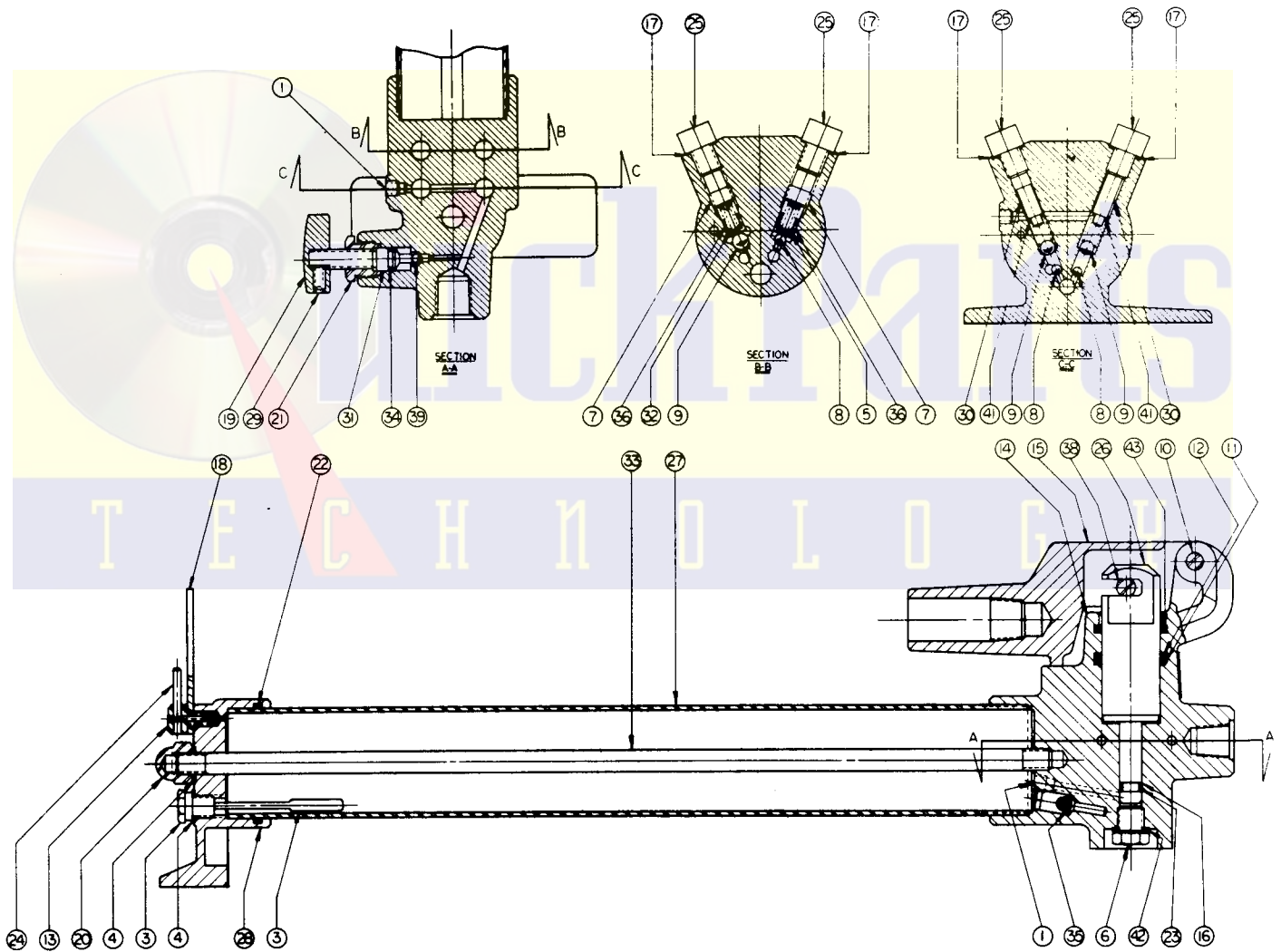

TO PROTECT YOUR WARRANTY, USE ONLY ENERPAC HYDRAULIC OIL.

PARTS LIST

PARTS LIST

Item No.	Part Number	Req. No.	Description	Item No.	Part Number	Req. No.	Description
1	A1006.245	4	Plug	23		1	"O"-Ring
2	AJ100.001	2	Screw	24	B1076.057	1	Pin (Spring)
3	B110.900	1	Filler Plug Ass'y.	25	CB821.006	4	Plug
4		2	Gasket	26	CB822.051	1	Plunger
5		1	Spring	27	CB823.025	1	Reservoir
6	B247.185	1	Plug	28	CB824.267	1	Pump Rest
7	B956.028	2	Nyloc Adj. Screw	29	CB825.028	1	Set Screw
8		3	Ball-.219"	30	CB826.186	2	Spacer
9		3	Ball-.312"	31	CB827.010	1	Release Spindle
10	B1168.057	1	Spring Pin	32		1	Valve Spring
11		1	"O"-Ring	33	CB829.149	1	Tie Rod
12		1	Back Up	34		1	"O"-Ring
13	CB809.024	1	Air Vent	35	E394.018	1	Filter
14	CB810.005	1	Base	36	L769.013	2	Ball Guide
15	CB811.060	1	Beam	38	P75.57	1	Cross Pin
16		1	Spiral Back-Up	39	P208.16	1	Valve Ball
17		4	Gasket	40	P515.245	1	Pipe Plug (Not Shown)
18	CB814.017	1	Hook	41	S1.183	2	Spring
19	CB815.381	1	Knob	42		1	Gasket
20	CB816.055	1	Nut	43		1	Square Section Seal Kit
21	CB817.011	1	Release Valve Nut		C7.900	1	Handle (Not Shown)
22		1	"O"-Ring				

Items 4, 5, 8, 9, 11, 12, 16, 17, 22, 23, 32,
34, 42 And 43 Are Included In Repair Kit
P-70K

NOTE: (#16) Use Loctite Retaining Compound #75

IMPORTANT – USER SAFETY AND PROTECTION

In setting up systems to fit your operations, care must be taken to select the proper components and design to insure appropriate integration with your operations and existing equipment and that all safety measures have been taken to avoid the risk of personal injury and property damage from your application or system.

ENERPAC CANNOT BE RESPONSIBLE FOR DAMAGE OR INJURY CAUSED BY UNSAFE USE, MAINTENANCE OR APPLICATION OF ITS PRODUCTS.
Please contact ENERPAC for guidance when you are in doubt as to the proper safety precautions to be taken in designing and setting up your particular application.

NOTE: Orders for parts cannot be filled unless both model and serial number with prefix imprinted on nameplate are given.

PARTS AND SERVICE

For quality workmanship and genuine ENERPAC parts, select a Franchised ENERPAC Service Center for your repair needs.

Only repairs performed by a Franchised Service Center displaying the official ENERPAC Franchised sign are backed with full factory warranty. The Classified Section in your Phone Book lists your nearest Franchised Service Center.

WARRANTY

ENERPAC warrants its products against defects in workmanship and materials for 90 days from date of delivery to user. Chain is not warranted.

Warranty does not cover ordinary wear and tear, abuse, misuse, overloading, altered products or use of improper fluid.

WARRANTY RETURN PROCEDURE

When question of warranty claim arises, the user should send his unit to the nearest ENERPAC Franchised Service Center for inspection, transportation to be prepaid and evidence of purchase date furnished. If the claim comes under the terms of our warranty, the Franchised Service Center will REPAIR OR REPLACE PARTS AFFECTED and return prepaid.

ENERPAC®

AN APPLIED POWER  INDUSTRY

ENERPAC, BUTLER, WISCONSIN 53007 DIVISION OF APPLIED POWER INC. TELEPHONE (414) 781-6600 TELEX 026-682

L-557 11/76 PRINTED IN U.S.A.