

Operator's Manual



Hydraulic Body Repair Kits

Models 50364 - 4 Ton Capacity
50347 - 10 Ton Capacity

- Safety
- Operation
- Maintenance
- Parts

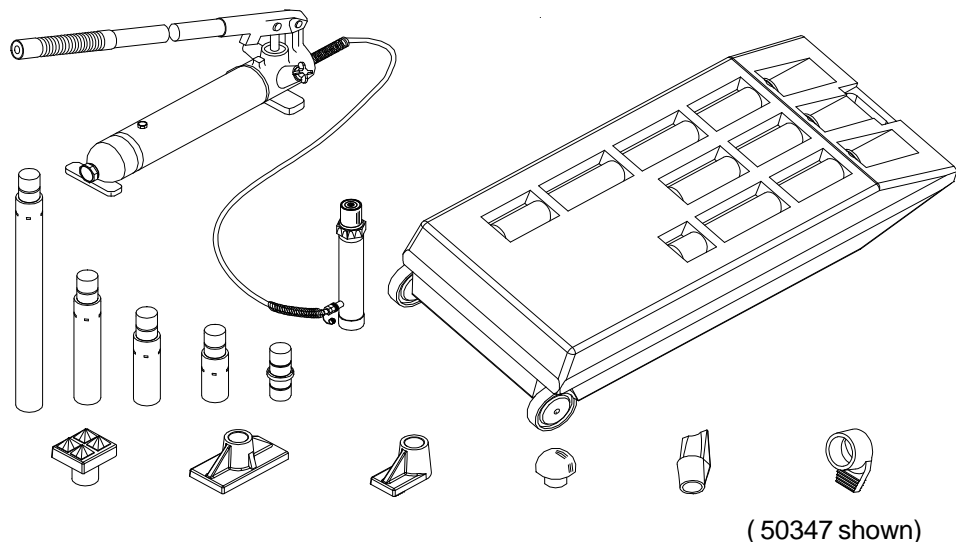

CAUTION: Before using this product, read this manual and follow all its Safety Rules and Operating Instructions.

ATENCIÓN: Leer, comprender, y seguir las instrucciones antes de utilizar el aparato. El manual de instrucciones y la información de seguridad deben estar comunicado en lengua del operador antes del uso. No seguir estas indicaciones puede causar daños personales o materiales.

Sears, Roebuck and Co., Hoffman Estates, IL 60179 U.S.A.

www.sears.com/craftsman

Part No. 50347-M0

Printed in China 06/05
© Sears, Roebuck and Co.

TABLE OF CONTENTS

WarrantyP2
Save These InstructionsP2
Product Description & SpecificationsP3
Safety InstructionsP3
OperationP6
MaintenanceP6
TroubleshootingP8

WARRANTY

FULL ONE YEAR WARRANTY

For one year from the date of purchase, if this product fails due to a defect in material or workmanship, Sears will repair it free of charge. Call 1-888-332-6419 for the location of the nearest authorized repair center.

This warranty applies only while this product is used in the United States. Warranty is void if product is leased or rented.

This warranty gives you specific legal rights, and you may also have other rights which vary from state to state.

Sears Roebuck and Co., Dept. 817WA, Hoffman Estates, IL 60179

SAVE THESE INSTRUCTIONS

For your safety, read and understand the information contained within.

The owner and operator shall have an understanding of this product and safe operating procedures before attempting to use this product. Instructions and Safety information shall be conveyed in the operator's native language before use of this product is authorized. Make certain that the operator thoroughly understands the inherent dangers associated with the use and misuse of the product. If any doubt exists as to the safe and proper use of this product as outlined in this manual, remove from service immediately.

Inspect before each use. Do not use if broken, bent, cracked or otherwise damaged parts are noted. If any component of this product has been or suspected to have been subjected to a shock load (a load dropped suddenly, unexpectedly upon it), discontinue use until checked out by Sears or qualified service center. Owners and operators of this equipment shall be aware that the use and subsequent repair of this equipment may require special training and knowledge. It is recommended that an annual inspection be done by qualified personnel and that any missing or damaged parts, decals, warning / safety labels or signs be replaced with factory authorized replacement parts only. Any component of this Repair Kit that appears to be damaged in any way, is worn or operates abnormally shall be removed from service immediately until such time as it can be repaired/replaced. Labels and Operator's Manuals are available from Sears (see PARTS section on page 8 & 9).

PRODUCT DESCRIPTION

CRAFTSMAN Hydraulic Body Repair Kits are designed to be used for pushing, spreading, and pressing of vehicle body panels as well as various component parts and assemblies. A variety of attachments are included. Pumps are rated from 8,000 to 10,000 PSI. Rams are rated from 4 to 10 tons. **WARNING:** when extension tubes and/or **offset** attachments are used, the rated capacity is always **reduced by 50%** for **each tube or offset attachment** connected. See Parts Section for identification of **offset** attachments.

SPECIFICATIONS

Model	Capacity	Ram		Number of Attachments	Weight
		Closed Height	Extended Height		
50364	4 Ton	11"	15 3/4"	14	46 lbs
50347	10 Ton	13 5/8"	19 3/4"	13	88 lbs

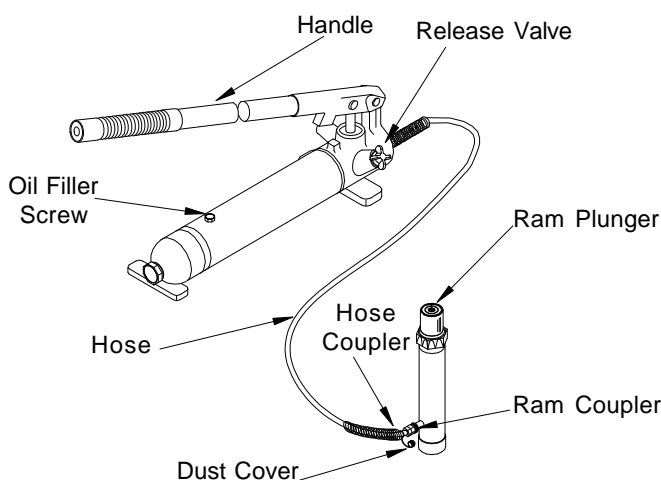

Figure 1 - Model No. 50364 & 50347 Components

SAFETY INSTRUCTIONS

BEFORE USE (Refer to Figure 1 above)

1. Study, understand, and follow all instructions provided with and on this device before use.
2. Inspect before each use. Do not use if bent, broken, leaking or damaged components are noted.
3. Ensure that product and application are compatible.
4. Check to ensure that all parts of your kit are included (see illustration and parts list).
5. Carefully remove the dust covers and plugs from hose coupler and ram coupler.
6. Connect hose coupler to ram coupler, ensure that there are no fluid leaks.
7. Locate and open release valve. Pump handle a few strokes to purge air from system. Close release valve and pump handle until ram is fully extended, then open release valve until ram has fully retracted.
8. With ram fully retracted and release valve open, place pump in horizontal position. Locate and open oil filler screw (on reservoir body, near the back). This will release air trapped within the reservoir. Retighten the oil filler screw.

ATENCIÓN

- Leer, comprender, y seguir las instrucciones antes de utilizar el aparato.
- El manual de instrucciones y la información de seguridad deben estar comunicados en lengua del operador antes del uso.
- No seguir estas indicaciones puede causar daños personales o materiales.

SAFETY INSTRUCTIONS (cont.)

GENERAL SAFETY INFORMATION

1. Ensure that attachments are fully engaged before applying load.
2. Ensure that load is centrally applied to attachment or ram saddle. Do not load off center.
3. Always monitor the force applied to workpiece by using a load cell and indicator or you may monitor pressure developed in the ram by using an inline pressure gauge, then calculate the applied force using the formula:
 $F = P \times A$, where F = lbs force, P = pressure in PSI, and A = effective ram area in².
Ram Area of 50364 is: 0.998 in²
Ram Area of 50347 is: 2.431 in²
4. If bowing or bending of ram or any attachment occurs during use, "**STOP**", release pressure immediately and reconsider application. Application may not be compatible with product, a ram kit with a higher capacity may be needed.

! DANGER !

- If oil leakage is detected, discontinue use of the ram immediately and contact your nearest Sears. The ram could develop excessive pressure and cause the ram, hose or coupler to burst which could cause serious injury or death.
- When loading a ram, always insure that coupler, port, and adapter threads have not been damaged. Failure to do so could cause serious injury or death.
- Avoid off-center loads. Loading off center may damage the ram and cause loss of load which may cause serious injury or death.
- Control the load at all times. Do not drop the load. Threads may shear and cause loss of the load, which may cause serious injury or death.



WARNING



To avoid crushing and related injuries:
NEVER work on, under or around a load supported only by ram. **ALWAYS** use adequately mechanical support such as rated jack stands.



WARNING

- **All WARNING** statements must be carefully observed to help prevent personal injury.
- Do not exceed rated capacity.
- Use only on hard, level surfaces capable of sustaining rated capacity loads.
- Do not open oil filler screw unless ram is fully retracted.
- Wear protective clothing and safety goggles to reduce the risk of injection.
- Do not wear sandals and jewelry when operating this equipment.
- Do not use as a vehicle lifting device or as a vehicle support.
- When extension tubes and/or offset attachments are used, the rated capacity is always reduced by 50% for each tube or attachment connected.
- Any attachment that is not loaded centrally, as through the centerline of the ram, is considered to be "offset". See parts section for identification of offset attachments.
- Monitor pressure and load at all times.
- Always verify load with calibrated load cell and indicator, known good pressure gauge or equivalent devices.
- Do not modify this device.
- Failure to heed these markings may result in personal injury and/or property damage.

Hydraulic Hoses and Fluid Transmission Lines

- Avoid short runs of straight line tubing. Straight line runs do not provide for expansion and contraction due to pressure and/or temperature changes.
- Reduce stress in tube lines. Long tubing runs should be supported by brackets or clips. Before operating the pump, all hose connections must be tightened with the proper tools. Do not overtighten. Connections should only be tightened securely and leak-free. Overtightening can cause premature thread failure or high pressure fittings to burst.

SAFETY INSTRUCTIONS (cont.)

WARNING

- Should a hydraulic hose ever rupture, burst or need to be disconnected, immediately shut off the pump and release all pressure. Never attempt to grasp a leaking pressurized hose with your hands. The force of escaping hydraulic fluid can inflict injury.
- Do not subject the hose to potential hazard such as fire, sharp objects, extreme heat or cold, or heavy impact.
- Do not allow the hose to kink, twist, curl, crush, cut or bend so tightly that the fluid flow within the hose is blocked or reduced. Periodically inspect the hose for wear, because any of these conditions can damage the hose and possibly result in personal injury.
- Do not pull, position or move setup by the hose. Doing so can damage the hose and possibly cause personal injury.
- Hose material and coupler seals must be compatible with hydraulic fluid used. Hoses also must not come in contact with corrosive materials such as battery acid, creosote-impregnated objects and wet paint. Hose deterioration due to corrosive material can result in personal injury. Never paint a coupler or hose.
- The user must be a qualified operator familiar with the correct operation, maintenance, and use of rams. Lack of knowledge in any of these areas can lead to personal injury.
- Use only approved accessories and approved hydraulic fluid.
- Do not exceed the rated capacity of the ram.
- Inspect each ram and coupler before each use to prevent unsafe conditions from developing.
- Do not use rams if they are damaged, altered or in poor condition.
- Do not use rams with bent or damaged coupler or damaged threads.
- Under certain conditions, the use of an extension with a hydraulic ram may not be advisable and could present a dangerous condition.
- Avoid pinch points or crush points that can be created by the load or parts of ram.
- To help prevent material fatigue if the ram is to be used in a continuous application, the load should not exceed 85% of the rated capacity.
- Ram must be on a stable base which is able to support the load while pushing or lifting.

WARNING

- Ensure ram is fully engaged into/onto adapters, extension accessories.
- To help prevent personal injury, use shims, friction material or constraints to prevent slippage of the base or load.
- Do not off-center loads on a ram. The load can tip or the ram can "kick out" and cause personal injury.
- As the load is lifted, use blocking and cribbing to guard against a falling load.
- Never allow personnel to work on, under or around a load before it is properly supported by appropriate mechanical means. Never rely on hydraulic pressure alone to support load.
- All personnel must be clear before lowering.
- Never try to disassemble a hydraulic cylinder, Refer repairs to qualified, authorized personnel.

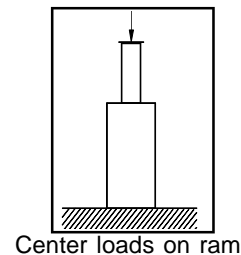

IMPORTANT

- Keep ram clean at all times.
- When the ram is not in use, keep the piston(s) fully retracted.
- Use an approved, high-grade pipe thread sealant to seal all hydraulic connections. Teflon tape can be used if only one layer of tape is used and it is applied carefully (two threads back) to prevent the tape from being introduced into hydraulic system. A piece of tape could travel through the system and obstruct the flow of fluid and adversely affect function.
- Never attach ANY component not authorized by Sears.

KNOW YOUR SYSTEM

Your ram, hose(s), couplings and pump all must be rated for the same maximum operating pressure, correctly connected and compatible with the hydraulic fluid used. An improperly matched system can cause the system to fail and possibly cause serious injury. If you are in doubt, consult Sears.

OPERATION

Note: Inspect before each use for evidence of fluid leaks, damaged hydraulic fittings, bent or broken attachments and missing parts.

1. Locate and close release valve by turning it clockwise until firmly closed. (Do not over tighten)
2. Operate by pumping handle. This will send fluid from the pump reservoir into the high pressure hose assembly and into the ram assembly.
3. Continue pumping until ram reaches desired height.

Note: Pump may be used in horizontal and vertical position as illustrated (See figure 2).

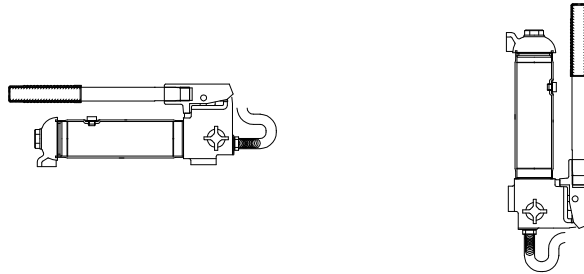

Figure 2 - Horizontal and Vertical Position

To Release Pressure on work piece:

Slowly, carefully turn the release valve counterclockwise until ram retracts to desired position. **Never turn release valve more than 1/2 full turn.** The ram return system is spring loaded, allowing controlled retraction of the ram.

MAINTENANCE

Important: Use only a good grade hydraulic oil. We recommend Mobil DTE13M. Avoid mixing different types of fluid and **Never** use brake fluid, turbine oil, transmission fluid, motor oil or glycerin. Improper fluid can cause failure of the pump and the potential for sudden and immediate loss of load.

Adding oil

1. With ram fully lowered, set pump unit in its normal, level position. Locate and remove oil filler screw (see Figure 1).
2. Fill until oil is within 3/8" (6 mm) of the hole opening, reinstall oil filler screw.

Changing oil

For best performance and increased system life, replace the complete fluid supply at least once per year.

1. With ram fully lowered, remove the oil filler screw from the pump reservoir as above.
2. Lay the pump on its side and drain the fluid into a suitable container.

Note: Dispose of hydraulic fluid in accordance with local regulations.

3. Set pump in its level upright position.
4. Fill with good quality hydraulic oil to within 3/8" of the oil filler screw hole opening. Reinstall oil filler screw.

Lubrication

A periodic coating of light lubricating oil to pivot points and hinges will help to prevent rust and assure that pump assemblies move freely.

Cleaning

Periodically check the pump piston and ram for signs of rust or corrosion. Clean as needed and wipe with an oily cloth.

Note: Never use sandpaper or abrasive material on these surfaces !

Storage

When not in use, store with the pump piston and ram fully retracted.

TROUBLESHOOTING

Symptom	Possible Causes	Corrective Action
Ram will not extend	<ul style="list-style-type: none"> • Release valve not tightly closed • Overload condition 	<ul style="list-style-type: none"> • Ensure release valve tightly closed • Remedy overload condition
Ram *bleeds off after lift	<ul style="list-style-type: none"> • Release valve not tightly closed • Hydraulic unit malfunction 	<ul style="list-style-type: none"> • Ensure release valve tightly closed • Replace ram and / or pump
Ram will not lower after unloading	<ul style="list-style-type: none"> • Reservoir overfilled • Ram damaged 	<ul style="list-style-type: none"> • Drain fluid to proper level • Replace ram
Poor performance	<ul style="list-style-type: none"> • Fluid level low • Air trapped in system 	<ul style="list-style-type: none"> • Ensure proper fluid level • With ram fully retracted, remove oil filler screw to let pressurized air escape, then reinstall oil filler screw
Will not lift to full extension	<ul style="list-style-type: none"> • Fluid level low 	<ul style="list-style-type: none"> • Ensure proper fluid level

* "Bleeds off" means that ram begins to slowly retract rather than maintain position

PARTS

When ordering replacement parts, please refer to the model number / serial number found on the product, then give the part number and description.

Model No. 50364 (4 Ton)

Ref No.	Part#	Description	Quantity
1	F040-41500-000	Extension Tube (19-1/2")	1
2	F040-41100-000	Extension Tube (16-1/2")	1
3	F040-41200-000	Extension Tube (8-1/2")	1
4	F040-41300-000	Extension Tube (6-1/8")	1
5	F040-41400-000	Extension Tube (3")	1
6	F040-41600-000	Male connector	1
7	F040-40001-000	Wedge Head	1
8	F040-40003-000	Serrated Saddle	1
9	F040-44000-000	Flat Base	1
10	F040-40005-000	Plunger Toe	1
11	F040-40004-000	Ram Toe	1
12	F040-43000-000	Rubber Head	1
13	F040-40002-000	Combination Head	1
14	F040-42000-000	Hydraulic Spreader (1000 lb. capacity)	1
15	F040-20012-000	Dust Cover - Hose	1
16	F040-34000-000	Dust Cover - Ram	1
17	F040-22201-000	Hose Coupler, Male	1
18	F040-90009-K02	Ram Coupler Assy, Female	1
19	F040-30000-000	Ram Assembly	1
20	F040-21000-000	Release Valve Knob	1
21	F040-90009-K03	Pump Handle	1
22	F040-22000-000	Hose Assembly (with coupler)	1
23	F040-90009-K01	Oil Filler Screw	1
24	F040-20000-000	Pump Assembly	1
25	F040-00001-000	Blow Molded Case	1
-	F0400S-85	Repair Kit	-
-	50364-L0	Label (not shown)	1
-	50347-M0	Manual	1

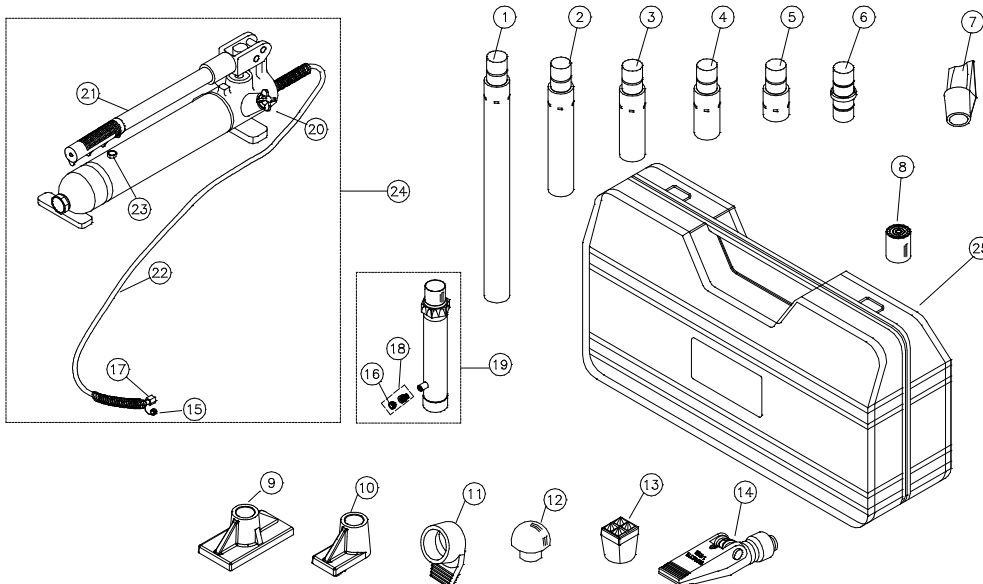

Figure 4 - Replacement Parts Illustration for Model 50364



Sears, Roebuck and Co.,
Hoffman Estates, IL 60179
Visit our Craftsman website: www.sears.com/craftsman



Get it fixed, at your home or ours!

For repair of major brand appliances **in your own home...**
no matter who made it, no matter who sold it!

1-800-4-MY-HOME[®] Anytime, day or night
(1-800-469-4663) (U.S.A. and Canada)
www.sears.com www.sears.ca

For repair of carry-in products like vacuums, lawn equipment,
and electronics, call for the location of your nearest
Sears Parts and Repair Center.

1-800-488-1222 Anytime, day or night (U.S.A. only)
www.sears.com

For the replacement parts, accessories and owner's manuals
that you need to do-it-yourself, call **Sears PartsDirectSM!**

1-800-366-PART 6 a.m. – 11 p.m. CST, 7 days a week
(1-800-366-7278) (U.S.A. only)

www.sears.com/partsdirect

To purchase or inquire about a Sears Service Agreement
or Sears Maintenance Agreement:

1-800-827-6655 (U.S.A.) **1-800-361-6665** (Canada)
7 a.m. – 5 p.m. CST, Mon. – Sat. 9 a.m. – 8 p.m. EST, M – F, 4 p.m. Sat.

Para pedir servicio de reparación a
domicilio, y para ordenar piezas:

1-888-SU-HOGARSM
(1-888-784-6427)

Au Canada pour service en français:

1-800-LE-FOYER^{MC}
(1-800-533-6937)
www.sears.ca

