

# REPAIR KIT INSTRUCTIONS HAND PUMP AND RAM

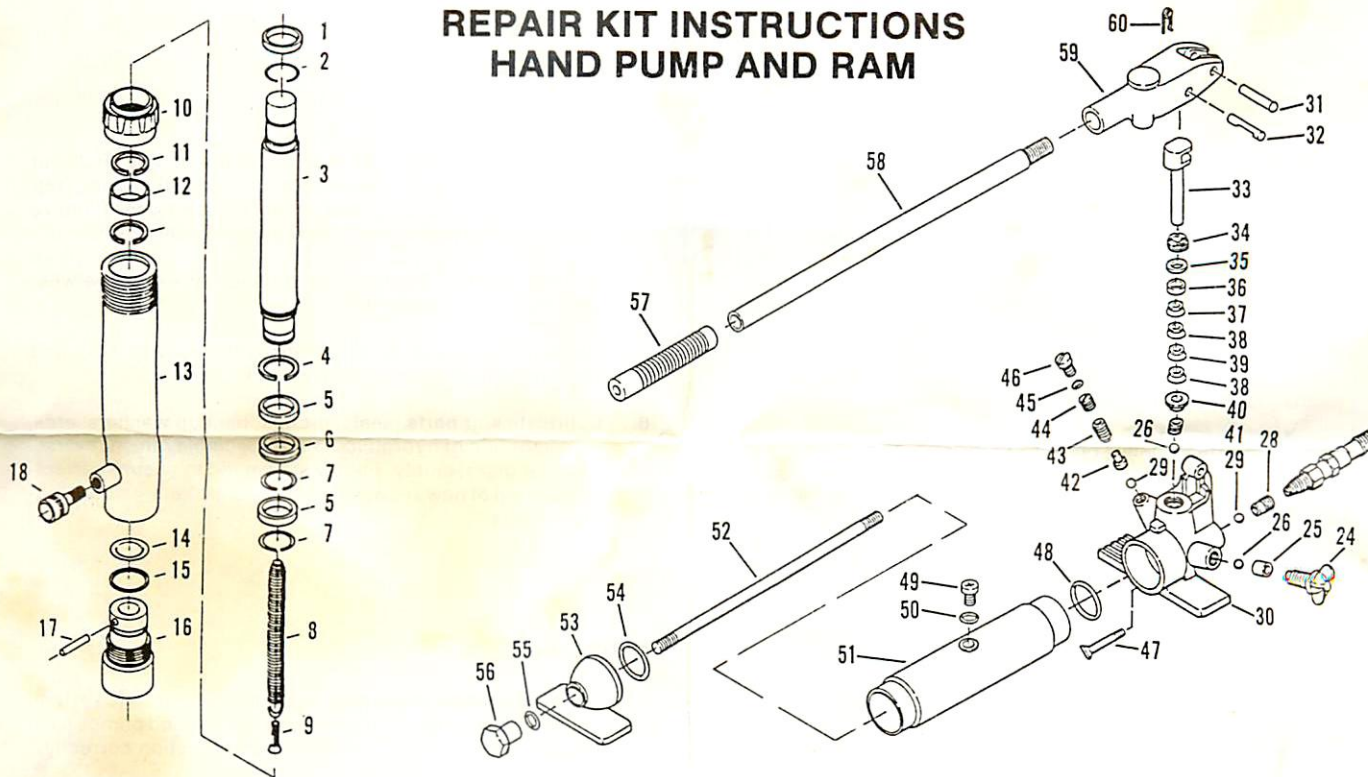

## ⚠ WARNING

1. READ, STUDY, UNDERSTAND AND FOLLOW ALL WARNING AND SERVICE INSTRUCTIONS PROVIDED WITH THIS SERVICE KIT. IF ANY OF THIS MATERIAL IS UNCLEAR CONTACT THE FACTORY SERVICE DEPARTMENT OR YOUR NEAREST AUTHORIZED SERVICE CENTER.
2. USE ONLY SERVICE PARTS SUPPLIED OR APPROVED BY THE MANUFACTURER OF THE ORIGINAL EQUIPMENT.
3. PRIOR TO SERVICING THE RAM, INSURE THAT THE PLUNGER IS FULLY RETRACTED AND ALL INTERNAL HYDRAULIC PRESSURE IS RELEASED.
4. DO NOT USE CONTAMINATED OIL. ALWAYS MAINTAIN CLEAN PARTS AND WORK AREA WHEN SERVICING THIS PUMP/RAM. CONTAMINATES WILL CAUSE INTERNAL VALVES TO MALFUNCTION, SEAL WEAR AND POSSIBLE PUMP/RAM FAILURE.
5. WHEN OFFSET ATTACHMENTS ARE USED, THE RATED CAPACITY IS ALWAYS REDUCED BY 50%. FOR EACH EXTENSION TUBE USED IN THE SETUP, THE OVERALL RATED CAPACITY IS REDUCED AN ADDITIONAL 50%. REFER TO THE OPERATING INSTRUCTIONS PROVIDED FOR TYPICAL SETUPS AND CORRESPONDING LOAD CAPACITIES.
6. DO NOT CONNECT PUMP TO ANY RAM THAT IS EXTENDED OR PARTIALLY EXTENDED.
7. PRIOR TO APPLYING A LOAD, INSURE THAT ALL ATTACHMENTS AND EXTENSION TUBES ARE FULLY ENGAGED.
8. INSURE THE LOAD IS CENTRALLY APPLIED TO ATTACHMENTS AND RAM SADDLE TO MINIMIZE AN OFF-CENTER LOAD CONDITION.
9. DO NOT OVERLOAD. SIGNS OF OVERLOADING MAY BE INDICATED BY BOWING EXTENSION TUBES OR SLIPPING ATTACHMENTS AND CAN RESULT IN PERSONAL INJURY OR DAMAGE TO THE EQUIPMENT.
10. THE MANUFACTURER RECOMMENDS THE USE OF A FORCE/PRESSURE GAUGE TO VERIFY THE ACTUAL LOAD OR PRESSURE BEING APPLIED FOR VARIOUS TYPES OF SETUPS USED.
11. USE ONLY HOSES SUPPLIED OR RECOMMENDED FOR THIS PUMP WHEN TESTING THIS UNIT AFTER SERVICE.
12. SEALS MUST BE INSTALLED PROPERLY TO INSURE ORIGINAL DESIGN PERFORMANCE. REFER TO SCHEMATIC FOR PROPER ASSEMBLY. THE U-CUP SEAL SHOULD BE POSITIONED WITH THE HEEL OF CUP AGAINST THE BEARING WITH LIPS FLARING OUT, DOWN AND AWAY FROM RAM ASSEMBLY.
13. BE CERTAIN RAM TOP BEARING GUIDE IS FULLY THREADED INTO CYLINDER AND POSITIONED CORRECTLY. REFER TO PARTS SCHEMATIC FOR PROPER ASSEMBLED POSITION.
14. DO NOT REMOVE, ADJUST OR TAMPER WITH THE OVERLOAD ADJUSTMENT OR COMPONENTS. THESE COMPONENTS ARE FACTORY PRESET AND MUST NOT BE ADJUSTED. IF SERVICE IN THIS AREA IS REQUIRED THE JACK MUST BE TAKEN TO A MANUFACTURER'S AUTHORIZED SERVICE CENTER.
15. AFTER SERVICE, TEST THE PUMP FOR THE ABILITY TO GENERATE FLOW AND PRESSURE AND THE FOLLOWING CONDITIONS: 1. SPONGINESS OF THE HANDLE. 2. DRIFTING OF THE PUMP PRESSURE. 3. HANDLE KICK. IF ANY OF THESE CONDITIONS EXIST, DO NOT USE THIS PUMP. TAKE IMMEDIATELY TO THE NEAREST AUTHORIZED SERVICE CENTER FOR REPAIR. CHECK FOR LEAKS AROUND ALL PORTS AND SEALS.
16. AFTER SERVICING, TEST THE RAM FOR THE ABILITY TO EXTEND, RETRACT AND HOLD RATED LOAD. WITH THE RAM HOLDING A STATIC LOAD CHECK FOR HYDRAULIC OIL LEAKS. WITH ALL EXTERNAL LOADS REMOVED AND NO INTERNAL HYDRAULIC PRESSURE THE RAM SHOULD RETRACT TO THE FULLY CLOSED POSITION.
17. DO NOT OPEN FILLER SCREW FOR ANY REASON, UNLESS RAM OR ACCESSORIES ARE FULLY RETRACTED.
18. MAINTAIN PROPER OIL LEVEL IN RESERVOIR. OVERFILLING MAY CAUSE DAMAGE TO, OR FAILURE OF THE PUMP. DO NOT USE BRAKE FLUID. USE ONLY THE MANUFACTURER'S RECOMMENDED HYDRAULIC OIL.
19. IT IS YOUR RESPONSIBILITY TO KEEP ALL WARNING LABELS AND INSTRUCTIONAL LITERATURE LEGIBLE AND INTACT. REPLACEABLE LABELS AND LITERATURE ARE AVAILABLE FROM THE FACTORY.
20. FAILURE TO HEED THESE WARNINGS MAY RESULT IN EQUIPMENT AND/OR PROPERTY DAMAGE AND/OR PERSONAL OR FATAL INJURY.

### PUMP

1. Secure pump base (30) in vise and remove reservoir nut (56) and end cap (53). Drain fluid from jack. Do not reuse hydraulic oil.
2. Remove retaining clip (60) and handle socket pin (31). Slide handle socket (59) back to disengage piston pin (32) from pump piston (33). Retain these parts for later use.
3. Open release valve (24) 3 full turns. Pull out pump piston (33) from pump base (30). Unscrew packing nut (34) and remove items (35, 36, 37, 38, 39, 40 & 26). Replace these items with new parts provided in kit.
4. Remove release valve (24), packing (25), and ball (26). Retain items (24 & 26) for later use. Replace packing (25) with new part provided in kit. Note: Do not remove plug (46) or items (45, 44, 43, or 42). These components are factory preset and should not be adjusted. If service in this area is required then take pump to the manufacturer's authorized service center.
5. Remove hydraulic hose (27), plug (28) and ball (29). Note position of filler screw in reference to pump base and mark tube (51) to ensure proper assembly. Remove reservoir tube (51) and bolt rod (52). Retain these parts for later use. Remove oil filter (47).



# REPAIR KIT INSTRUCTIONS

## HAND PUMP AND RAM

6. Wash all parts including pump base (30) with non-flammable solvent and ensure clean circuitry channels. *Maintain clean parts and work area for assembly. Use only manufacturer's specified hydraulic oil. DO NOT USE BRAKE FLUID.*
7. Lubricate soft parts (seals, u-cups, backup washers, etc.) with light film of hydraulic oil and assemble pump in reverse order of disassembly. Follow schematic to ensure correct installation of new seals, bearings, and gaskets maintaining cleanliness.
8. Remove filler plug (49) and position hydraulic pump assembly in a horizontal position. Add hydraulic oil to reservoir with 8 fluid ounces for pumps with short reservoir tubes (51) and 21 fluid ounces for pumps with long reservoir tubes (51). Oil level in reservoir is important as under-or-overfilling will cause poor pump performance. Install filler plug (49).
3. Secure ram plunger (3) in a brass jawed vise. Pull out cylinder base and disconnect from return spring (8). Remove items (5 & 7) and retain for later use. Remove u-cup (6) and replace with new part provided in kit.
4. Inspect all other bearings for damage or excessive wear and replace as required.
5. Remove items (14 & 15) from cylinder base (16) and replace with new parts provided in kit.
6. Lubricate soft parts (seals, u-cups, backup washers, etc.) with light film of hydraulic oil and assemble ram in reverse order of disassembly. Follow schematic to ensure correct installation of new seals, bearings, and gaskets maintaining cleanliness.

### RAM

1. Secure ram cylinder (13) in vise and remove coupler (18). Unscrew cylinder base (16) until all threads are exposed and part is no longer connected to cylinder (13).
2. Use brass hammer to tap lightly on end of ram plunger (3) until entire assembly (cylinder base & ram plunger) is removed through bottom of cylinder. Note the ram collar (1) is pressed onto ram plunger and will be forced OFF during removal of ram plunger assembly. Retain this part for later use.

### GENERAL

1. Following repair, there may be air in the hydraulic system, causing the pump to be "air bound." Air bound pumps have spongy piston action and often fail to function correctly.
2. To bleed air from the hydraulic system — connect pump to ram and place pump in horizontal position. Place ram so that ram plunger is pointed downward. The ram and hose must be lower than the pump discharge port. Open release valve 2 full turns and activate pump handle for 10 full strokes slowly. Close release valve and activate pump to extend ram plunger fully, then release. Repeat if necessary.