



PARTS SHEET
MODEL 5-51307
CAPACITY 1-1/2 TON
APRIL 1973

SS-710B

GENERAL INFORMATION

This Jack is equipped with a 3-Way Air Valve for convenience in jacking. Air may be introduced through a hose permanently attached to the 1/4 inch pipe thread on the one side of the valve or through a hose equipped with a tire chuck through the fitting on top of the valve.

A special feature incorporated in the Jack is the Mechanical Safety Lock designed to support the load in the event of loss of air.

The Jack must be positioned and brackets adjusted as close to bumper brackets as possible. All wheels on car must be free to roll.

The Mechanical Safety Lock must be released prior to depressing the valve handle. To disengage safety lock, open valve allowing air into the cylinder to raise lift so that safety lock may be pulled to release safety release plunger. Hold in this position while releasing air from cylinder.

The design incorporates a full floating cylinder and piston within the tank and a link support to the carriage. This assures self alignment at all times.

LUBRICATION

Use a high grade machine oil and lubricate the following points:

1. The front and rear rollers located on the carriage.
2. The front caster wheel.
3. The ball bearing rear wheels.

Rated capacity of 1 1/2 tons is obtained with 140 pounds of air pressure.

TO ORDER PARTS

Order parts from your Franchised Service Depot, giving part number and complete name.

Repair Kit is Number 5 563

WARRANTY

These Jacks, Pumps and Rams are fully guaranteed against defective material and workmanship for 90 days from date of original sale to user when submitted or shipped with proof of purchase date, transportation prepaid, to the nearest franchised service depot for inspection. (Do not return to factory.) This warranty does not cover units that have been altered or attachments added to them which are not recommended by the manufacturer. The use of hydraulic brake or shock absorber fluid, alcohol, kerosene or other deleterious fluids voids this warranty as does improper use through overloading or any other abusive practice or accident.

AUTO SPECIALTIES MANUFACTURING COMPANY

St. Joseph, Michigan

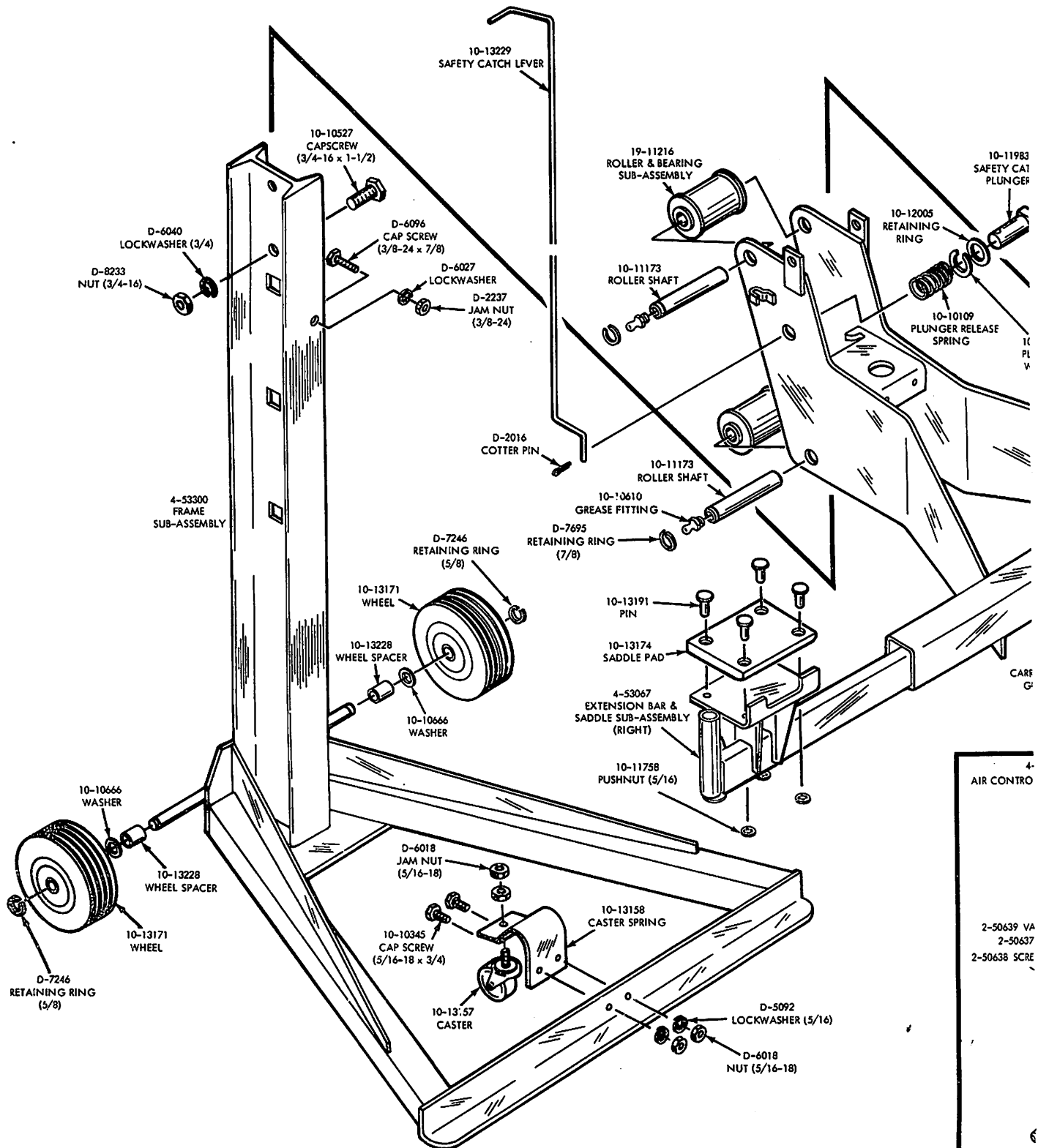

4-
 AIR CONTROL
 2-50639 VA
 2-50637
 2-50638 SCRE

