

ATD TOOLS, INC.

PRODUCT SPECIFICATIONS

MODEL #:	7485
DESCRIPTION:	HYDRAULIC ENGINE CRANE
CAPACITY:	2 TON
BASE LENGTH:	71 1/4"
BASE WIDTH (FRONT):	30 3/4"
BASE WIDTH (REAR):	32 5/8"
EXTENSION BOOM	
LOCK POSITION P1:	
CAPACITY	2 TON
MIN. HOOK HEIGHT:	10 3/4"
MAX. HOOK HEIGHT:	79 1/4"
BOOM LENGTH:	50 1/8"
LOCK POSITION P2:	
CAPACITY	1 1/2 TON
MIN. HOOK HEIGHT:	4"
MAX. HOOK HEIGHT:	83"
BOOM LENGTH:	57 1/4"
LOCK POSITION P3:	
CAPACITY	1 TON
MIN. HOOK HEIGHT:	0"
MAX. HOOK HEIGHT:	86 3/4"
BOOM LENGTH:	64 3/8"
LOCK POSITION P4:	
CAPACITY	1/2 TON
MIN. HOOK HEIGHT:	0"
MAX. HOOK HEIGHT:	90 1/2"
BOOM LENGTH:	71 1/2"
NET WEIGHT:	235.9 LBS
GROSS WEIGHT:	253.5 LBS
CARTON BOX # 1/3:	32 1/2" (L) X 26" (W) X 5 3/4" (H)
CARTON BOX # 2/3:	73 1/4" (L) X 6 3/4" (W) X 5" (H)
CARTON BOX # 3/3:	52 3/4" (L) X 14 1/4" (W) X 8 3/4" (H)
CUFT.:	8.03 CUFT (3 BOXES total, 123 PCs/ 20' CTN)

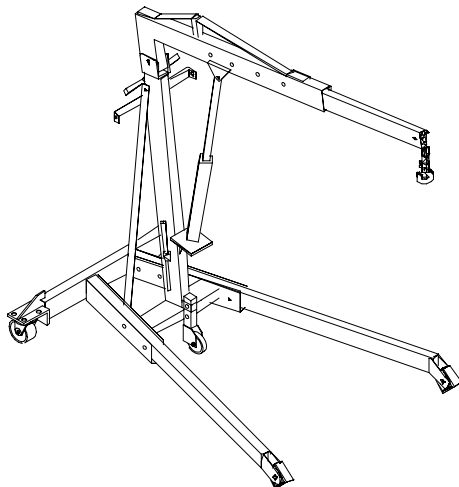

FEATURE

- MEETS ASME/ANSI - PALD SAFETY STANDARDS
- SPACE SAVER CRANE IS CONSTRUCTED OF HEAVY GAUGE WELDED TUBULAR STEEL
- HEAVY GAUGE STRUCTURAL STEEL
- THE SPECIAL 8 TON HYDRAULIC LONG RAM EQUIPPED PATENTED BUILT-IN BY-PASS DEVICE MECHANISM
- ADJUSTABLE FRONT & REAR LEGS FOR VERSATILITY IN POSITIONING HOIST
- TOOLS / PARTS TRAY DESIGN



SPARE PARTS LIST

Model # Atd-7485

ITEM	PARTCODE	DESCRIPTION	QTY	ITEM	PARTCODE	DESCRIPTION	QTY
1	N/A	boom	1	34	T1476-00-00012	snap pin	2
2	T1476-01-00000	boom extension	1	35	*	nut M12	2
3	T1476-09-00000	chain & hook assy.	1				
4	T1476-96-00000	power unit	1	36	T1476-00-00003	5 " wheel	2
5	T1476-08-00000	power unit bracket	1	37	T1476-00-00004	pipe (I)	2
				38	*	bolt M12 X 75	2
6	T1476-97-00000	handle	1	39	*	nut M8	1
7	N/A	base	1	40	T1476-00-00008	3" wheel	1
8	T1476-06-00000	leg extension (R)	1				
9	T1476-07-00000	leg extension (L)	1	41	T1476-00-00009	pipe (II)	1
10	T1476-02-00000	support bracket	1	42	*	bolt M8 X 65	1
				43	T1476-00-00012	snap pin	1
11	T1476-00-00001	support bar	1	44	T1476-00-00006	pin	1
12	N/A	post assembly	1	45	#	nut M8	1
13	T1476-00-00002	handle bracket	1				
14	T1476-04-00000	handle assembly	1	46	#	3 1/2" wheel	2
15	*	bolt M16 X 75	1	47	#	pipe	2
				48	#	bolt M8 X 65	2
16	*	nut M16	1	49	*	bolt M16 X 75	2
17	*	bolt M12 X 70	1	50	*	washer 8	8
18	*	nut M12	1				
19	*	bolt M8 X 12	4	51	*	springer washer 8	8
20	T1476-00-00010	stopper	1	52	*	bolt M8 X 20	8
				53	*	nut M8	8
21	*	bolt M12 X 60	1	54	*	bolt M12 X 80	1
22	*	nut M12	1	55	*	bolt M20 X 100	1
23	*	nut M10	2				
24	*	springer washer 10	2	56	*	bolt M8 X 20	2
25	*	bolt M10 X 35	2	57	*	bolt M6 X 10	3
				58	#	caster bracket	2
26	*	nut M20	1	59	*	bolt M16 X 75	1
27	*	nut M12	1	60	*	nut M12	1
28	*	nut M12	2				
29	*	bolt M12 X 30	2	61	T1476-98-00000	3 1/2" caster assy.	2
30	*	nut M16	1	62	T1476-99-00000	hardware kit pack	1
31	*	bolt M12 X 75	2				
32	*	nut M16	2				
33	T1476-00-00005	pin (I)	2				

Included in caster assembly
 * Included in hardware kit package

