

ATD TOOLS, INC.

PRODUCT SPECIFICATIONS

MODEL #:	7454
DESCRIPTION:	SHOP PRESS WITH BOTTLE JACK
CAPACITY:	20 TON
RAM STROKE:	9 1/8"
OVERALL HEIGHT:	64 1/2"
WIDTH:	28 "
INTERIOR WIDTH:	28"
BED WIDTH:	8 5/8"
CHANNEL WIDTH:	4"
WORKING SPACE MIN.:	2 1/2 "
WORKING SPACE MAX.:	29 5/8"
BED POSITION:	8
NET WEIGHT:	235.4 LBS

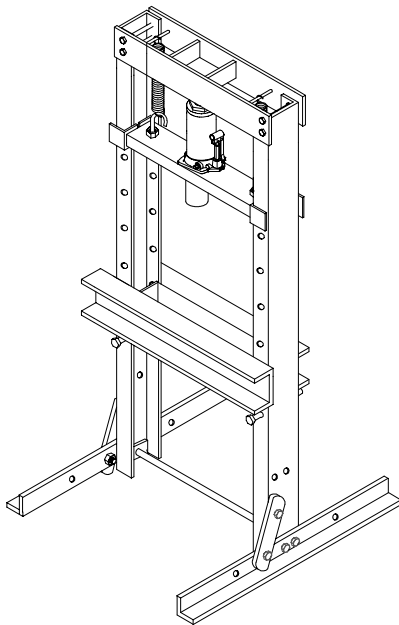

FEATURE

- AUTOMATIC RAM RETRACTION WHEN JACK VALVE IS OPENED
- RUGGED WELDED CONSTRUCTION WITH RIGID STEEL CHANNEL FRAMES
- HEAVY DUTY REINFORCED ANGLE STEEL BED PROVIDES A STABLE WORK AREA



20 Ton Hydraulic Shop Press Spare Parts List

Model # Atd-7454

ITEM	PARTCODE	DESCRIPTION	QTY	ITEM	PARTCODE	DESCRIPTION	QTY
1	*	column	2	15	T126-01000-000	head assy.	1
2	T184-00006-000	base leg	2	16	5314-00010-000	spacer 10	4
3	5102-10025-000	bolt (HCS M10 X 25)	16	17	T126-02000-000	jack bracket	1
4	5306-00010-000	spring washer	18	18	5103-10130-000	bolt	2
5	5202-00010-000	nuts	14	19	T060-00001-100	spring	2
6	T184-00005-000	column support	2	20	T060-00002-100	hook	2
7	T184-00004-000	frame support	2	21	5202-00008-000	hex nut M8	2
8	T125-01000-000	press bed pin	2	22	B200-10000-000	hydraulic power unit	1
9	*	bed frame	1	23	T126-03000-000	handle assy.	1
10	*	head support	2	24	T125-00007-000	arbor plate	2
11	5101-16150-000	bolt (HCS M16 X 150)	4	25	T12-6-0400-0000	hardware kits	1
12	5301-00016-000	spacer 16	8				
13	5306-00016-000	lock washer 16	4				
14	5202-00016-000	hex nut M16	4				

* part is not available

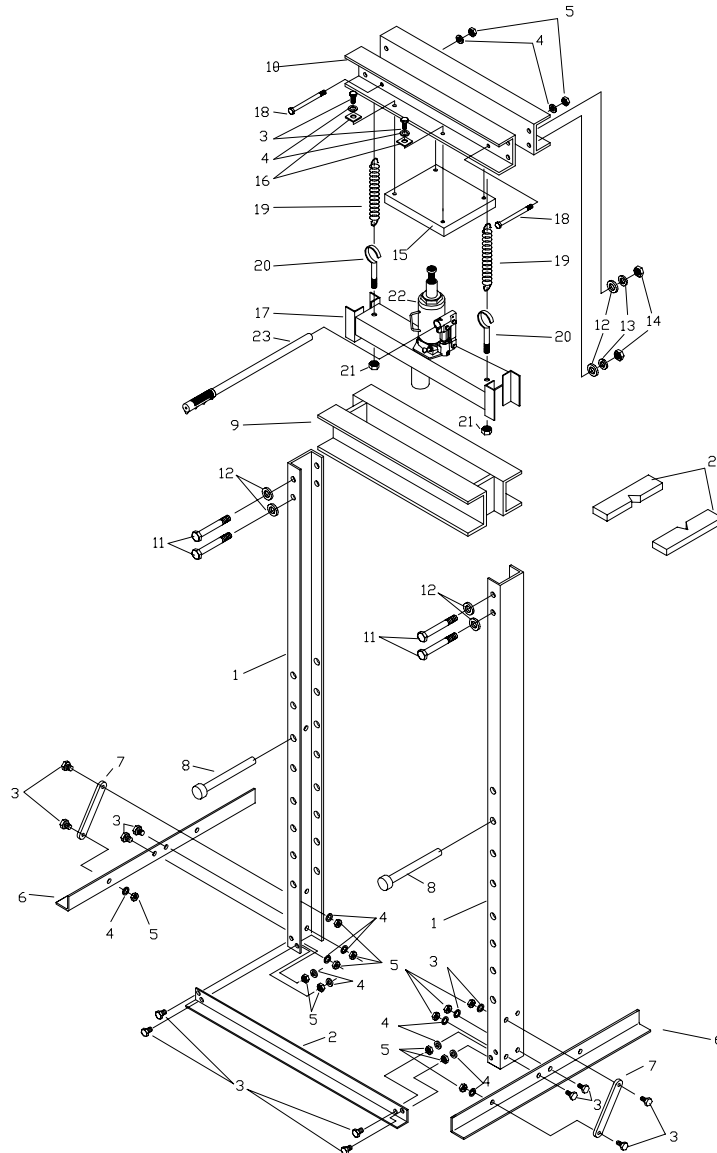

Exploded Drawing
1st Edition © Feb. 2001