

HYDRAULIC SHOP PRESS

25 TON CAPACITY

Models 91-618, 93618, YA-618 91-627, 93627, YA-627

Series "A"

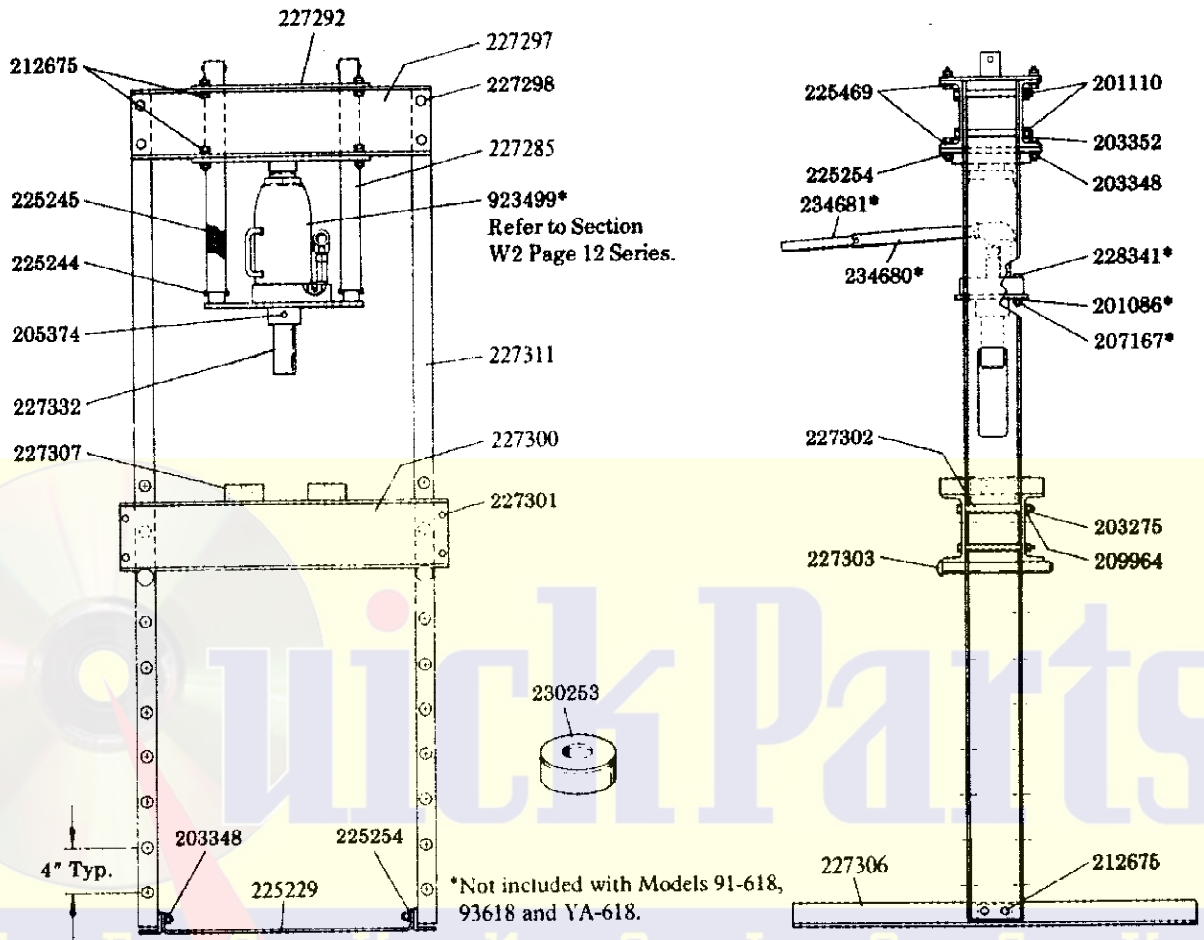

MODEL	LABEL KIT NO.
91-618 91-627	240077
93618 93627	240078
YA-618 YA-627	240080

SPECIFICATIONS

CAPACITY (TONS)	HEIGHT	BASE WIDTH	PRESS BED WIDTH	BASE DEPTH	PRESS BED DEPTH	RAM TRAVEL	WORKING RANGE (RAM TO BED)
25	74-3/4"	27"	Outside - 29-1/4" Inside - 23-1/2"	36"	9"	8"	Min. - 3-3/4" Max. - 39-3/4"

LINCOLN

A PENTAIR COMPANY

One Lincoln Way
St. Louis, MO 63120-1578
(314) 679-4200
Customer Service, (314) 679-4300

SECTION - **W8**
PAGE - **2C**

SERVICE PARTS

PART	QUAN.	DESCRIPTION	PART	QUAN.	DESCRIPTION	PART	QUAN.	DESCRIPTION
201088	2	Lockwasher	225245	2	Spring	227306	2	Base
201110	4	Lockwasher	225254	12	Lockwasher	227307	2	Arbor plate
203275	4	Jam nut	225469	8	Washer (beveled)	227311	2	Side post
203348	12	Jam nut	227285	1	Head assembly	227332	1	Stud
209352	4	Jam nut	227292	1	Top plate	228341	2	Bolt
205374	1	Set screw	227297	2	Cross member	230253	1	Bearing shield
207167	2	Nut	227298	4	Bolt	234680	1	Handle - release end
209964	4	Lockwasher	227300	2	Bed channel	234681	1	Handle - grip end
212675	12	Bolt	227301	4	Bolt	923499	1	Hydraulic unit
225229	1	Link strap	227302	4	Spacer			
225244	4	Pin	227303	2	Pin			

ASSEMBLY INSTRUCTIONS

Note: All angles and channels are to face out. Use exploded view as an assembly guide.

1. Assemble Bases and Link Strap to Side Posts using 212675 Bolts, 225254 Lockwashers and 203348 Nuts.

2. Assemble Cross Members to side posts using 227298 Bolts, 201110 Lockwashers and 203352 Nuts.

NOTE: The cross member with logo, name plate and caution label determines front of press.

3. Place Head Assembly in position from under cross members (position jack mounting holes in jack platform to rear of press). Fasten with 212675 Bolts, 225469 Beveled Washers, 225254 Lockwashers, and 203348 Nuts as shown in Detail "A". Do not tighten nuts.

4. Place Top Plate in position on top of cross members. Fasten with 212675 Bolts, 225469 Beveled Washers, 225254 Lockwashers and 203348 Nuts as shown in Detail "A". Tighten head assembly after tightening top plate.

5. Assemble one Bed Channel to each side of side posts with 227302 Spacers between them. Use 227301 Bolts (pass thru bed channels and spacers), 209964 Lockwashers and 203275 Nuts to complete this assembly.

6. When tightened, the bed should be readily adjustable along side posts without binding. In use it is supported in the desired position by 227303 Pins passing thru the appropriate holes in the side posts.

7. The 227332 Stud is affixed to a collar on the bottom of the head assembly by a 205374 Set Screw.

8. Place the shop press jack on the Jack Platform, lining up the drilled holes in the base of the jack with the holes in the jack platform. Secure jack with bolts and nuts included in jack carton.

NOTE: Read instruction manual enclosed with jack before use.

212675 Bolt — 1/2 - 13 x 1-1/2"

227298 Bolt — 5/8 - 11 x 6-1/2"

227301 Bolt — 3/8 - 24 x 6-1/2"

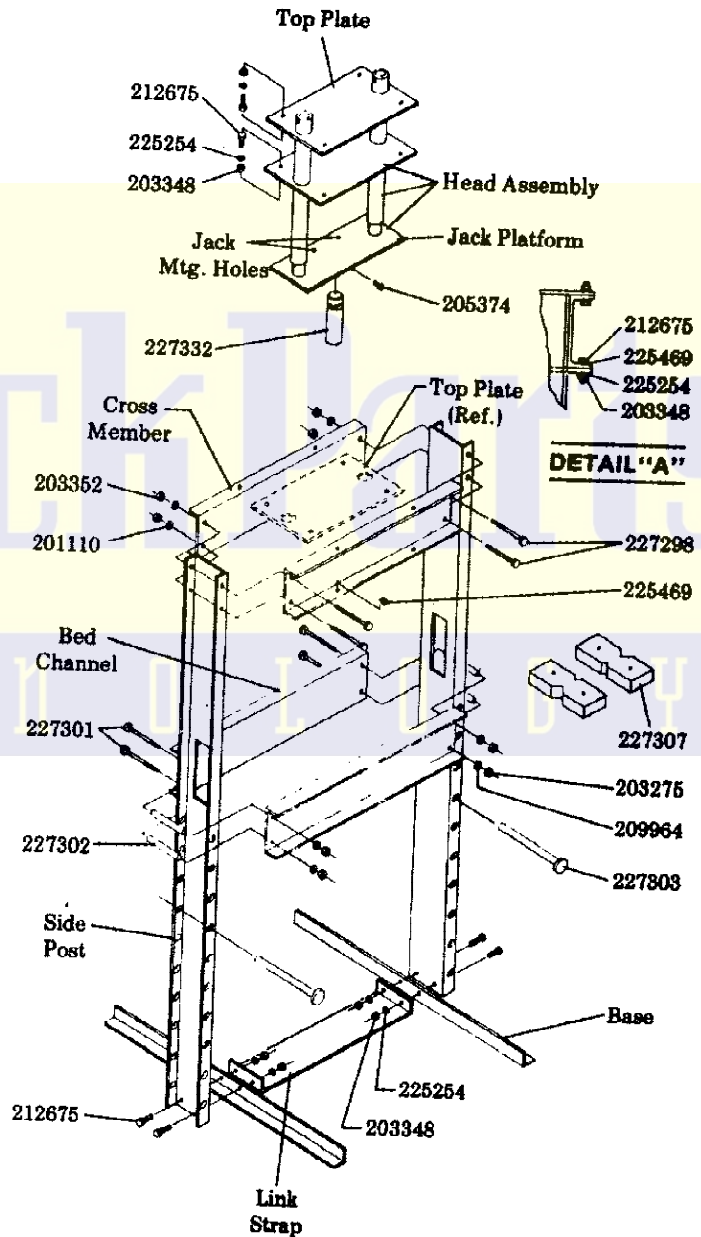

RETAIN THIS INFORMATION FOR FUTURE REFERENCE

When ordering replacement parts, list: Part Number, Description, Model Number, and Series Letter.

LINCOLN provides a Distributor Network that stocks equipment and replacement parts.
A list of Authorized Service Departments will be furnished upon request.