

# SHOP PRESS JACK

25 TON CAPACITY

Models 91-234  
93234, YA234  
Series "C"

## SPECIFICATIONS

Height (Closed)	Power Raise	Height (Max)	Handle Length
11"	7-5/8"	18-5/8"	20-1/2"

MODEL	LABEL KIT NO.	REPAIR KIT NO.
91-234	236675	91-415
93234	236677	236681
YA234	236679	236681

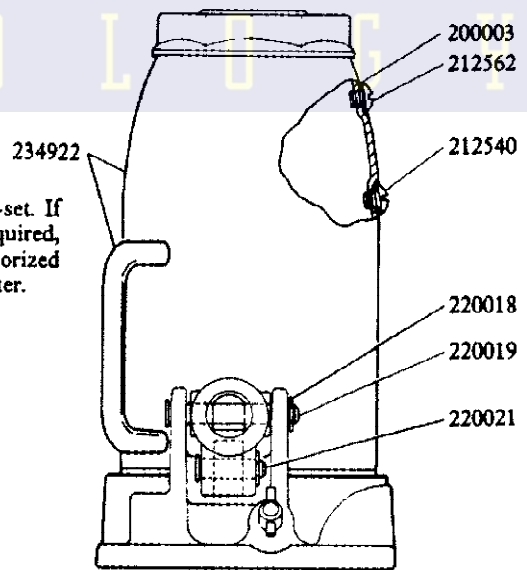
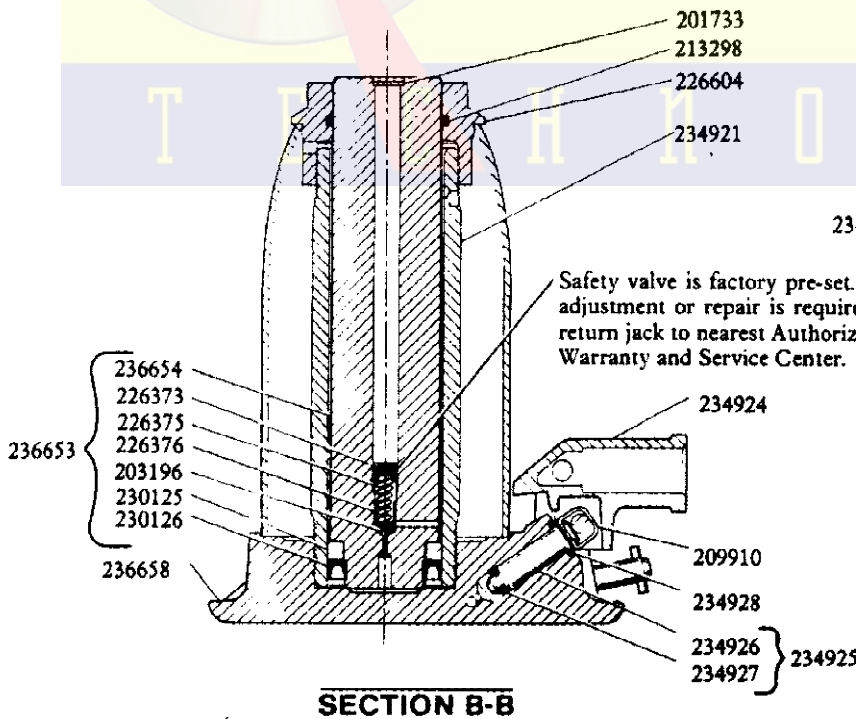
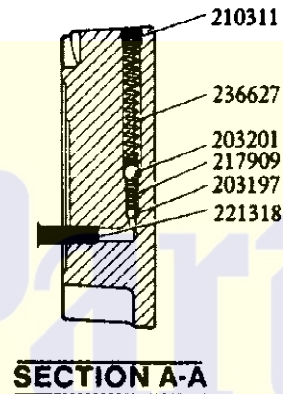
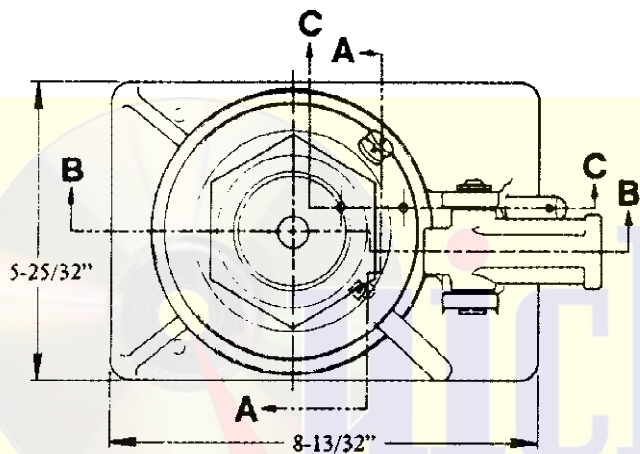
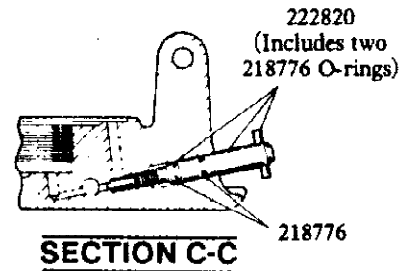
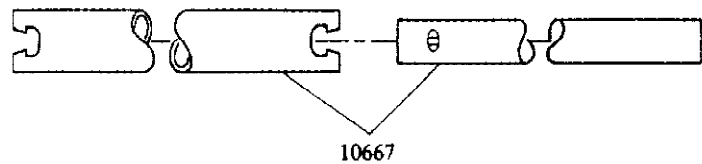

**LINCOLN**

A PENTAIR COMPANY

One Lincoln Way  
St. Louis, MO 63120-1578  
Customer Service, (314) 679-4300

SECTION - **W2**

PAGE - **14**

## TROUBLESHOOTING

PROBLEM	SOLUTION
1) Will not lift full height. 2) Will not lower completely.	Reservoir could be overfilled - With jack upright; remove filler screw, open release and SLOWLY push jack ram into lowered position. Any excess oil will run out fill hole. Replace filler screw when oil has stopped flowing.
1) Will not lift load. 2) Will not lift full height. 3) Pump feels "spongy" under load.	The jack could be low on oil - With jack in upright position and ram fully lowered, remove filler screw and fill reservoir with clean Hydraulic Jack Oil - correct oil level is reached when oil level is at bottom edge of fill hole.  The jack could be air bound - Open the release valve one full turn and pump the handle vigorously. Close the release valve and pump to full height. Continue pumping several times at full height. Open release valve and push ram down into lowered position. Close release valve and operate normally.
1) Will not lift load. 2) Handle raises under load. 3) Handle lowers under load.	Valve might not be closing - With release valve closed and ram in fully lowered position, SLOWLY raise ram to full height. Open release valve and push ram down into lowered position. Jack should now operate properly.
In cold ambient conditions; 1) Will not lift load. 2) Pump feels "spongy" under load.	The jack might not be vented - Jack must be vented in cold ambient conditions. With vent screw open approximately two turns, open the release valve one full turn and pump the handle vigorously. Close the release valve and pump to full height. Continue pumping several times at full height. Open release valve and push ram down into lowered position. Close release valve and operate normally.
1) Will not work in horizontal position.	Jack in wrong position for horizontal operation - Valving plug on side of jack base must face upward.  The jack could be low on oil - With jack in upright position and ram fully lowered, remove filler screw and fill reservoir with clean Hydraulic Jack Oil - correct oil level is reached when oil level is at bottom edge of fill hole.

If the above procedures do not correct the problem, contact your nearest Authorized Warranty and Service Center. When submitting any jack or equipment to be repaired, be sure to state the nature of the problem and indicate whether an estimate of the repair cost is needed.

**IMPORTANT:** As with any hydraulic unit, this unit may occasionally become "air bound" due to being tipped over during shipment. To purge the air from the oil lines, open the release and pump rapidly a few strokes. Close release and pump to full height, then open the release to allow the ram to descend rapidly. If the pump still seems "spongy", repeat the procedure.

## SERVICE PARTS

PART	QUAN.	DESCRIPTION	PART	QUAN.	DESCRIPTION
10667	1	Handle	226604	1	Tank nut
*200003	2	Gasket	226373	1	Adjusting nut
201733	1	Plug	226375	1	Spring
203196	1	Ball	226376	1	Adjusting valve
*203197	1	Ball	*230125	1	Heel plate
*203201	1	Ball	*230126	1	U-cup packing
209910	1	Pump clip	234921	1	Cylinder
*210311	1	Pipe plug	234922	1	Oil tank & handle ass'y.
212540	1	Filler screw	234924	1	Handle socket
212562	1	Vent screw	234925	1	Pump ass'y.
*213298	1	O-ring	234926	1	Pump piston
*217909	1	Spring	*234927	1	U-cup packing
*218776	2	O-ring	*234928	1	Wiper
220018	2	Retaining ring	*236627	1	Spring
220019	1	Fulcrum pin	236653	1	Ram ass'y.
220021	1	Pump pin	236654	1	Ram
*221318	1	Suction screen	236658	1	Base
222820	1	Release stem ass'y.			

\* Included in 236681 and 91-415 Repair kit.