

PORTABLE HYDRAULIC JACK

3 TON CAPACITY

Model 91-226,93226, 95226,YA-226

Series " T "

SPECIFICATIONS:

Height (Closed): 6-1/2"
 Extension Screw: 3-1/2"
 Maximum Height: 18"
 Power Raise: 8"

MODEL	LABEL KIT NO.	REPAIR KIT NO.
91-226	240029	91-411
93226	240030	240504
95226	240031	240504
YA-226	240032	240504

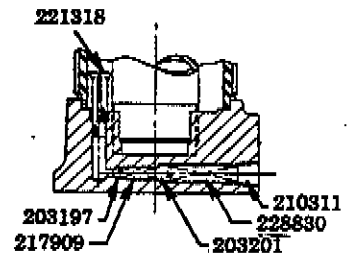
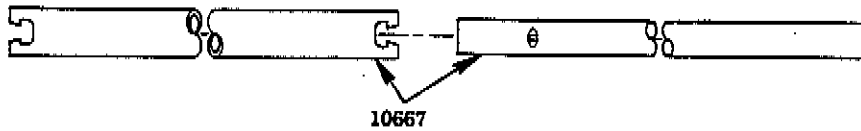

SECTION A-A

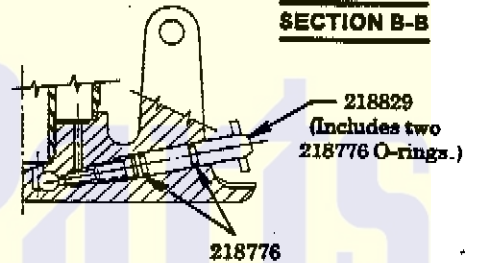
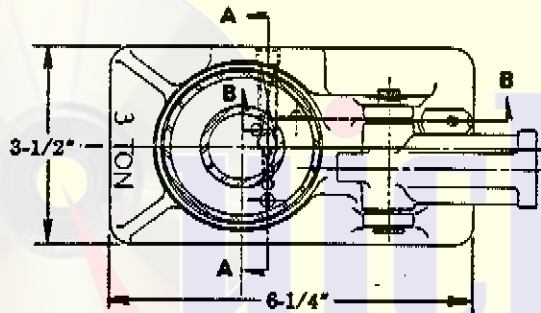

SECTION B-B

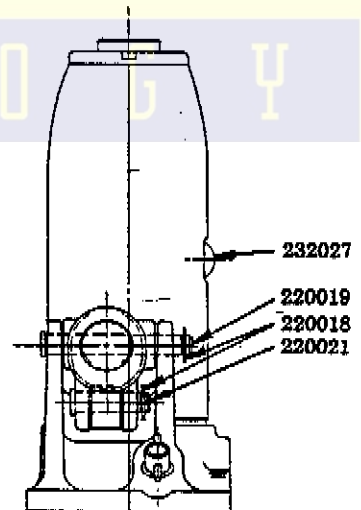
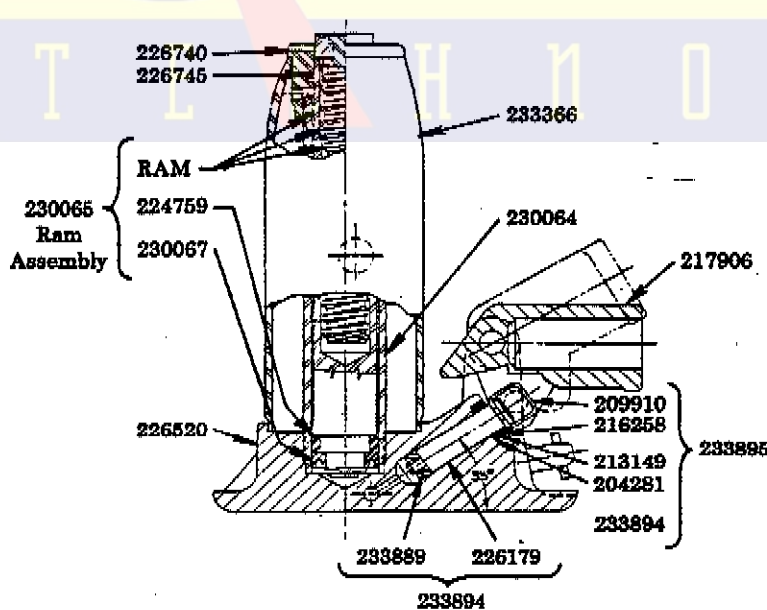

LINCOLN ST. LOUIS
 4010 GOODFELLOW BLVD. • ST. LOUIS, MO. 63120 • (314) 679-4200



SECTION - **W2**
 PAGE - **7**

SERVICE PARTS

PART	QUAN.	DESCRIPTION	PART	QUAN.	DESCRIPTION
10667	1	Handle	*221318	1	Suction screen
*203197	1	Ball	*224759	1	Heel plate
*203201	1	Ball	226179	1	Pump piston
*204281	1	Washer	226520	1	Base
209910	1	Pump clip	226740	1	Tank nut
*210311	1	Pipe plug	*226745	1	Quad ring
*213149	1	Packing ring	*228830	1	Spring
*216258	1	Pump gland cover	230064	1	Cylinder
217906	1	Handle socket	230065	1	Complete ram assembly
*217909	1	Spring	*230067	1	U-cup packing
*218776	2	O-ring	*232027	1	Filler plug
218829	1	Release stem & o-ring ass'y.	233366	1	Oil tank
220018	2	Retaining ring	*233689	1	U-cup packing
220019	1	Fulcrum pin	233894	1	Pump assembly
220021	1	Pump pin	233895	1	Complete pump ass'y.

*Included in 240504 Repair Kit.

TROUBLE SHOOTING

PROBLEM	SOLUTION
1) Will not lift full height. 2) Will not lower completely.	Reservoir could be overfilled — with jack upright; remove filler screw or filler plug, open release and SLOWLY push jack ram into lowered position. Any excess oil will run out fill hole. Replace filler screw or filler plug when oil has stopped flowing.
1) Will not lift load. 2) Will not lift full height. 3) Pump feels "Spongy" under load.	The Jack could be low on oil — with jack in upright position and ram fully lowered, remove filler screw or filler plug and fill reservoir with clean HYDRAULIC JACK OIL — correct oil level is reached when oil level is at bottom edge of fill hole. The Jack could be air-bound — open the release valve one full turn and pump the handle vigorously. Close the release valve and pump to full height. Continue pumping several times at full height. Open release valve and push ram down into lowered position. Close release and operate normally.
1) Will not lift load. 2) Handle raises under load. 3) Handle lowers under load.	Valve might not be closing — make certain release valve is closed. Starting with ram in fully lowered position, SLOWLY raise ram out to full height. Open release valve and push ram down into lowered position. Jack should now operate properly.
1) Will not work in horizontal position.	Jack in wrong position for horizontal operation — valving plug on side of jack base must face upward. The Jack could be low on oil — with jack in upright position and ram fully lowered, remove filler screw or filler plug and fill reservoir with clean HYDRAULIC JACK OIL — correct oil level is reached when oil level is at bottom edge of fill hole.

If the above procedures do not correct the problem, contact your nearest service depot. When submitting any jack or equipment to be repaired, be sure to state the nature of the problem and indicate whether an estimate of the repair cost is needed.

IMPORTANT: As with any hydraulic unit, this unit may occasionally become "air-bound" due to being tipped over during shipment. To purge the air from the lines, open the release and pump rapidly a few strokes. Close release and pump to full height, then open the release to allow the ram to descend rapidly. If the pump still seems "spongy", repeat the procedure.

RETAIN THIS INFORMATION FOR FUTURE REFERENCE

When ordering replacement parts, list: Part Number, Description, Model Number, and Series Letter.

LINCOLN ST. LOUIS provides a Distributor Network that stocks equipment and replacement parts.

A list of Authorized Service Departments will be furnished upon request.