

Model X-10

Part Code H05085 — 10 Ton (9072 Kg.) Capacity

Model CF10H

Part Code H05226 — 10 Ton (9072 Kg.) Capacity

INSTRUCTION MANUAL REPAIR PARTS LIST



WARNING



1. THIS IS A LIFTING DEVICE ONLY. LOAD MUST BE SUPPORTED BY OTHER APPROPRIATE MEANS BEFORE GETTING UNDER VEHICLE FOR ANY REASON.
2. DO NOT OVERLOAD. OVERLOADING CAN CAUSE DAMAGE TO OR FAILURE OF THE JACK.
3. THIS JACK IS DESIGNED FOR USE ONLY ON HARD LEVEL SURFACES CAPABLE OF SUSTAINING THE LOAD. USE ON OTHER THAN HARD LEVEL SURFACES CAN RESULT IN JACK INSTABILITY AND POSSIBLE LOSS OF LOAD.
4. FAILURE TO HEED THESE WARNINGS MAY RESULT IN LOSS OF LOAD, DAMAGE TO JACK AND/OR FAILURE RESULTING IN PERSONAL INJURY OR PROPERTY DAMAGE.

OWNER'S RESPONSIBILITY

Operation. The owner and/or operator shall have an understanding of these operating instructions and warnings before operating the jack. Warning information shall be emphasized and understood. If the user is not fluent in English, the instructions and warnings shall be read to and discussed with the operator in the operator's native language by the purchaser/owner, making sure that the operator comprehends its contents.

Maintenance. The jack shall be maintained in accordance with instructions listed under "Maintenance."

Inspection

1. Visual inspection shall be made before each use of the jack, checking for leaking hydraulic fluid, and damaged, loose or missing parts.
2. Each jack, if subjected to an abnormal load shock, shall be inspected immediately by an authorized Hein-Werner/CF Industrial service center.
3. Owners and/or users should be aware that repair of this equipment may require specialized knowledge and facilities. It is recommended that an annual inspection of the jack be made by an authorized service center and that any defective parts, decals or warning labels be replaced with genuine Hein-Werner/CF Industrial parts. A list of authorized service centers is available upon request.

Damaged Jacks. Any jack which appears to be damaged in any way, is found to be badly worn, or operates abnormally **SHALL BE REMOVED FROM SERVICE** until necessary repairs are made by an authorized service center.

SPECIFICATIONS

Saddle Low Point	7-3/8"
Saddle High Point	26"
Length of Chassis	61"
Length of Handle	46"
Overall Length	105"
Frame Height	10"

INSTRUCTIONS BEFORE USE

1. Open release valve by turning knob on top of handle counter-clockwise. Pump handle six full strokes to assure proper internal lubrication, and to bleed any air from the hydraulic system. If handle is locked, lift lever on side of handle to release.
2. Squirt a small amount of hydraulic jack oil or lightweight motor oil on the pump pistons. Pump handle several times to distribute oil.
3. Thoroughly lubricate all moving parts of the jack. Raise the saddle to full height by closing release valve and pumping handle. Oil the surface of the ram as well as all moving parts in the handle and lifting mechanism. Grease all grease fittings except the large fitting on top of reservoir which is an air vent.

OPERATION

1. **Lifting** - Secure vehicle by blocking wheels. Close release valve by turning knob on top of handle clockwise. Dolly jack until lift saddle is centered under load and pump handle.
NOTE: Handle can be locked in two positions for dollying - straight up and at a 45° angle. To lock handle: lift lever on side of handle, move handle to desired position and push lever in. To unlock handle for pumping: lift lever on side of handle. Handle will remain unlocked until lever is pushed in again.



WARNING



**USE JACK FOR LIFTING ONLY.
ALWAYS SUPPORT VEHICLE WITH
VEHICLE SUPPORT STANDS.**

Always center the load on the saddle of your jack. Off-center loads and loads lifted while jack is not level may damage the jack or cause personal injury.

2. **Lowering** — Slowly turn release knob counterclockwise. Avoid "shock loads" created by quickly opening and closing the release knob as the load is being lowered. This may result in overloading of the hydraulic circuit and possible damage to the jack.

MAINTENANCE

1. Regularly check oil level. Use only genuine Hein-Werner/CF Industrial hydraulic jack oil in the unit of your jack. Never use alcohol or hydraulic brake fluid.

To check oil level: jack must be at rest, saddle down. Remove filler screw and inspect oil level. Level should be just up to the filler screw.

2. Keep the jack clean and well lubricated. Raise the saddle to full height and oil the surface of the ram often, as well as all moving parts in the handle, the pump pistons and the lifting mechanism. Frequently add grease to all fittings.

NOTE: Do not add grease to air vent fitting on top of reservoir tube.

HANDLE ASSEMBLY (H05243)

Hein-Werner/CF Industrial Service and Service Parts are available only through your local authorized Hein-Werner/CF Industrial Service Centers.

ITEM NO.	PART CODE	DESCRIPTION	REQ'D. QTY.
1	17985	Release Rod Hanger	1
2	24160	Washer	1
3	05267	Pin & Ring Assembly	1
4	12415	Pin Ring	1
5	18090	Quadrant Lock	1
6	05264	Pin & Ring Assembly	1
7	12165	Pin Ring	1
8	09750	Grease Fitting	3
9	26470	Set Screw	2
10	18140	Handle Fork	1

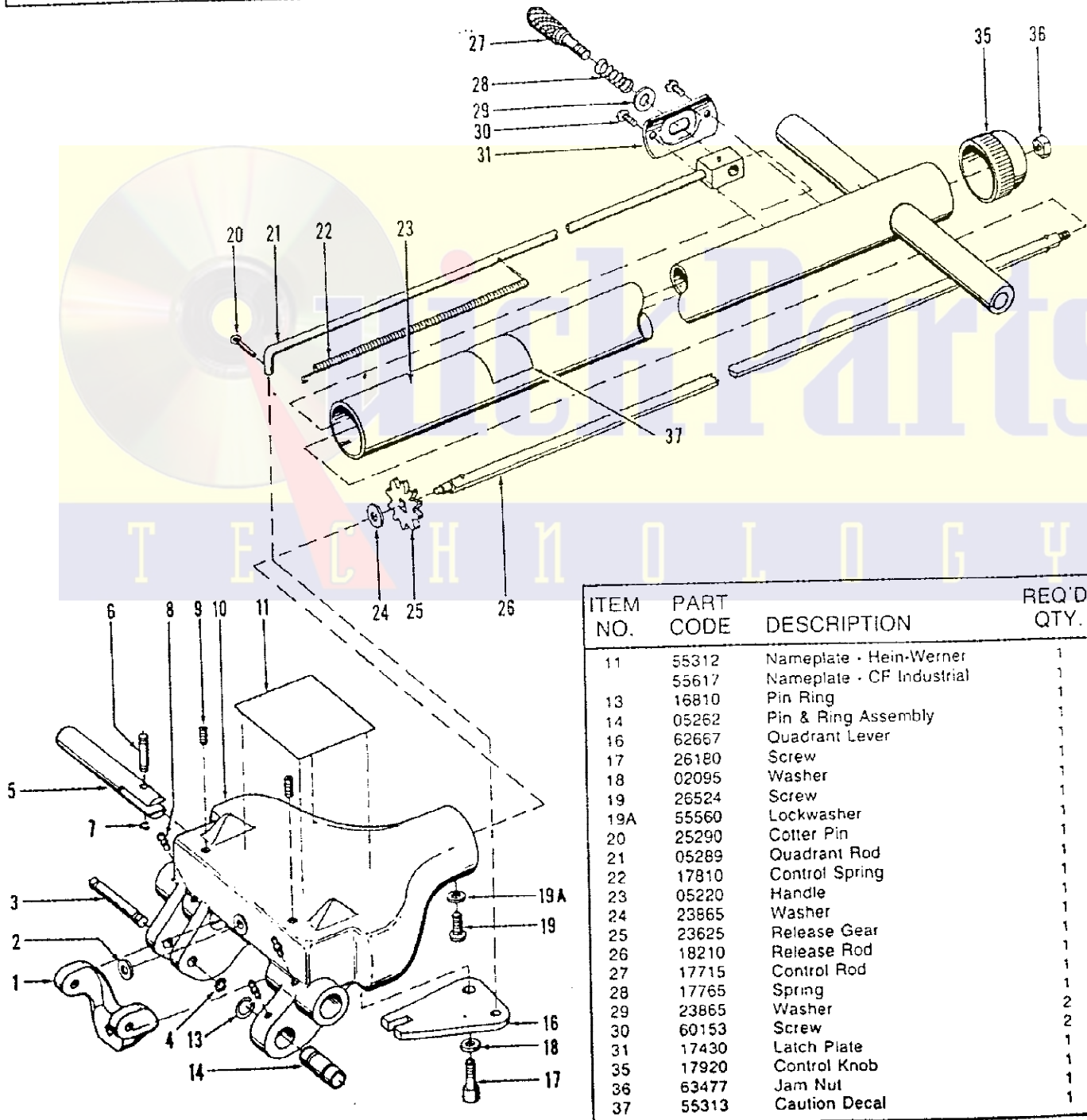

ITEM NO.	PART CODE	DESCRIPTION	REQ'D. QTY.
11	55312	Nameplate - Hein-Werner	1
	55617	Nameplate - CF Industrial	1
13	16810	Pin Ring	1
14	05262	Pin & Ring Assembly	1
16	62667	Quadrant Lever	1
17	26180	Screw	1
18	02095	Washer	1
19	26524	Screw	1
19A	55560	Lockwasher	1
20	25290	Cotter Pin	1
21	05289	Quadrant Rod	1
22	17810	Control Spring	1
23	05220	Handle	1
24	23865	Washer	1
25	23625	Release Gear	1
26	18210	Release Rod	1
27	17715	Control Rod	1
28	17765	Spring	1
29	23865	Washer	2
30	60153	Screw	2
31	17430	Latch Plate	1
35	17920	Control Knob	1
36	63477	Jam Nut	1
37	55313	Caution Decal	1

UNIT ASSEMBLY (H05323)

ITEM NO.	PART CODE	DESCRIPTION	REQ'D. QTY.
1*	16355	O-Ring	1
1A	24385	Ram Packing Nut (Old Style)	1
1B*	24435	Ram Packing (Old Style)	1
1C*	24430	Ram Packing (Old Style)	1
2	64171	End Nut	1
2A	24335	End Nut (Old Style)	1
3	08445	Reservoir Tube	1
4	05115	Air Vent Assembly	1
5	65929	Ram Assembly (1.75" dia.)	1
5A	05190	Ram Assembly (Old Style-1.5")	1
9	08440	Cylinder	1
10	64208	Quad Ring	1
11	25935	Pipe Plug	1
12	60141	Filler Screw	1
12A	04730	Washer	1
13	17890	Valve	1
14	18035	Spring	1
15	17785	Washer	1
16	17960	Plug	1
17*	80345	Pump Valve	2

ITEM NO.	PART CODE	DESCRIPTION	REQ'D. QTY.
18	80819	Pump Valve	1
21	17520	Adjusting Screw Only	1
23	16906	Spring	1
25	17055	Spring Cap	1
27	17220	Ball	1
28	82102	Unit Body - Corked (Includes Items 13-28)	1
29	09750	Grease Fitting	1
30*	18015	Packing-High Speed	1
31	18110	Packing Nut-High Speed	1
32	18020	Piston - H.S. (1.5" Dia.)	1
33†	05267	Pin & Ring Assembly	1
34†	12415	Pin Ring	1
36†	05080	Release Rod Ext. Assy.	1
40†	24290	Link	1
41*	14610	O-Ring	1
42	19575	Release Screw	1
43	08375	Washer	1
44	19585	Release Screw Nut	1
45	19505	Yoke	1
46	14840	Roll Pin	1
47†	16020	Spring	1
48*	18055	Packing - High Pressure	1
49	18125	Packing Nut - H.P.	1
50*	18065	Piston-H.P. (.6875 dia.)	1
51†	24295	Link	2
52†	05262	Pin & Ring Assembly	1
53†	16810	Clip	1
54	07345	Seal	1
55	03580	Plug	1

Hein-Werner/CF Industrial Service and Service Parts are available only through your local authorized Hein-Werner/CF Industrial Service Centers.

OLD STYLE 1.5" RAM

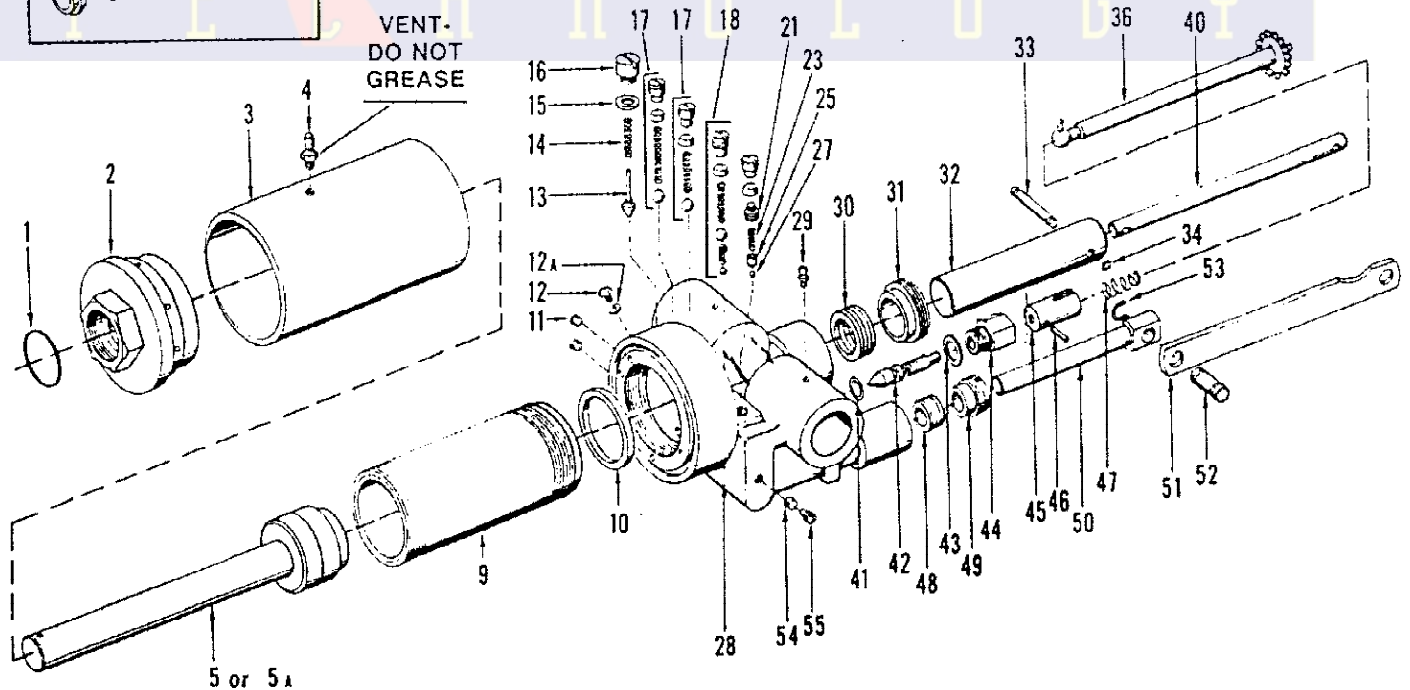
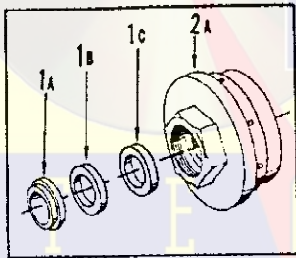

*Unit Repair Kit (Part Code 80753)

†Not Included With Unit Assembly (Part Code 05323)

CHASSIS ASSEMBLY

ITEM NO.	PART CODE	DESCRIPTION	REQ'D. QTY.
1	64178	Saddle Stud	1
2	08430	Saddle	1
3	64175	Pin	1
4	64035	Saddle Holder	1
	64406	Saddle Holder (Old Style)	1
5	14841	Roll Pin	1
6	64177	Lift Arm w/Grease Fittings	1
7	64176	Connector Pin (Accepts 1.75" Ram)	1
8	25781	Roll Pin	1
9	65300	Cover	1
9A	60687	Decal, Hein-Werner	1
10	64174	Pin	1
11	64182	R.H. Side Bar w/Bushing & Handle Stop	1
	24350	Old Style R.H. Side Bar w/Bushing & Handle Stop	1
12	24365	Front Axle	1
13	21006	Clamp	1
14	17940	Pull-Back Spring	1
15	24330	Tie Rod	1
16	14841	Roll Pin	1
17	64183	Parallel Link	2
18	64179	Parallel Link Stud	2
19	24270	Arm Pivot Pin	1
20	25335	Jam Nut (1/2-13)	6
21	24310	Handle Stop	1
22	24375	Rear Tie Rod	1
23	17825	Sleeve Bearing	2
24	20955	Rivet	2
25	24315	Front Axle Bushing	2
26	62245	Bearing	36

ITEM NO.	PART CODE	DESCRIPTION	REQ'D. QTY.
27	08395	Front Wheel	2
28	09750	Grease Fitting	
29	17755	Washer	1
30	17670	Snap Ring	2
31	64181	L.H. Side Bar w/Bushing	1
	24355	Old Style L.H. Side Bar w/Bushing	1
32	02180	Washer	4
33	26730	Jam Nut	4
34	64184	Washer	4
35	25231	Jam Nut	2
36	02520	Lockwasher	2
37	24370	Jam Nut	2
38	24420	Caster Bracket	2
39	14960	Bearing	2
40	16525	Jam Nut	2
41	02156	Lockwasher	6
42	61319	Bolt	6
43	19675	Thrust Bearing	2
44	21740	Bearing Race	4
45	24395	Caster Fork	2
46	16810	Pin Ring	2
47	05331	Pin & Ring Assembly	2
48	05210	Caster Assembly	2
49	16385	Needle Bearings	4
50	17410	Caster Wheel	2
51	62477	External Retaining Ring	2
52	24305	Unit Pivot Pin	1
53	17975	Fork Pin	2
	82048	HW Orange Paint-13 oz. spray	1
	67055	CF Green Paint-13 oz. spray	1
	60180	Hydraulic Oil (Quarts)	1

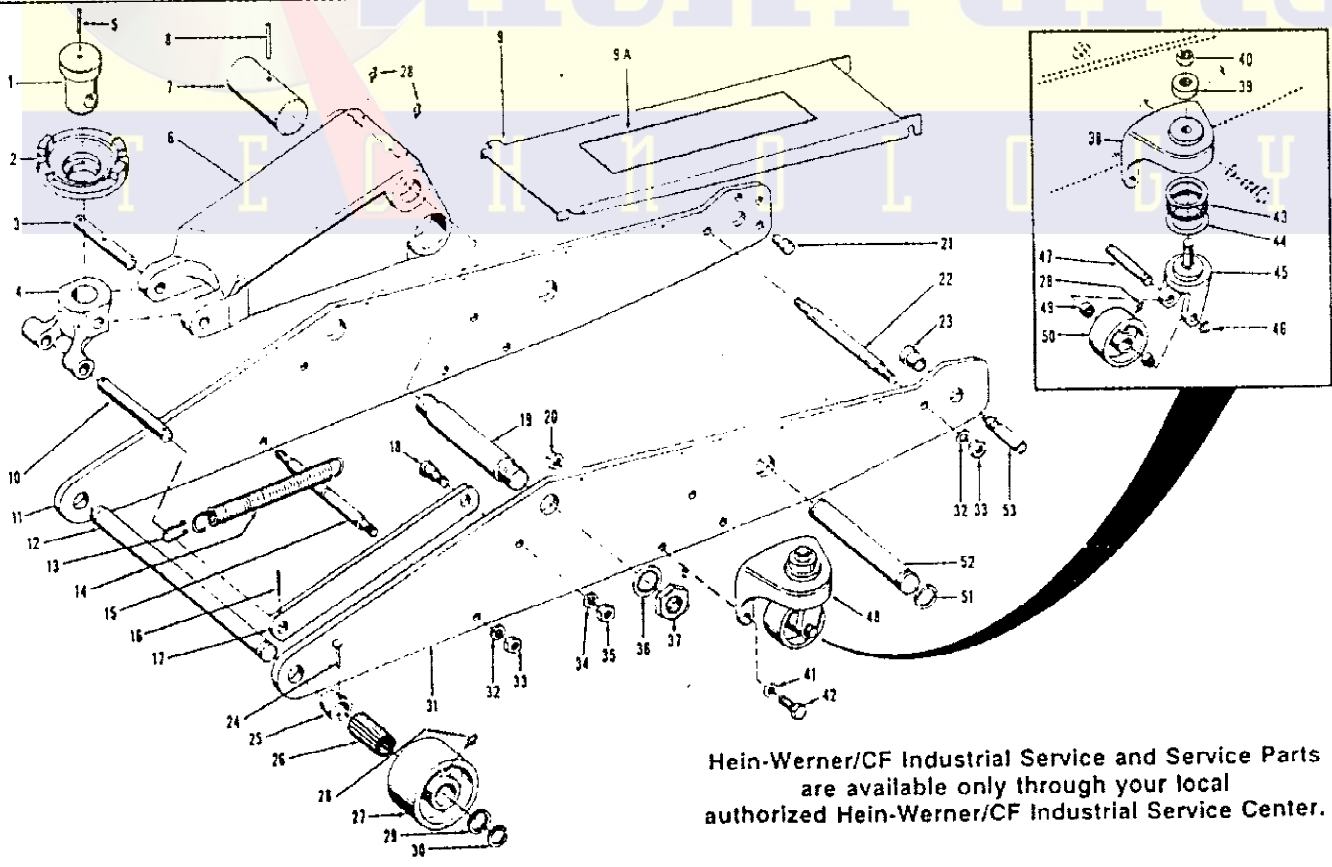

Hein-Werner/CF Industrial Service and Service Parts are available only through your local authorized Hein-Werner/CF Industrial Service Center.