

KNOCK-DOWN CRANES

1 TON CAPACITY

Model 91-804, 93804 95804, YA-704

Series "B"

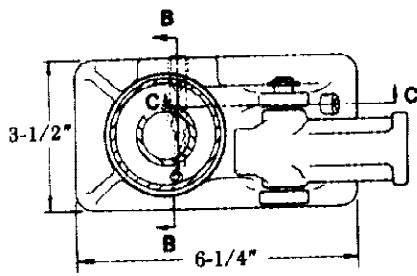

SECTION A-A

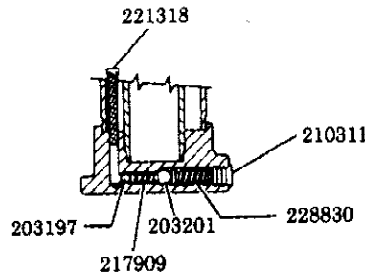

SECTION B-B

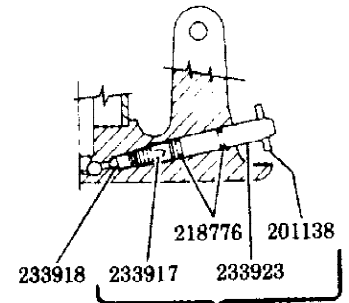

SECTION C-C

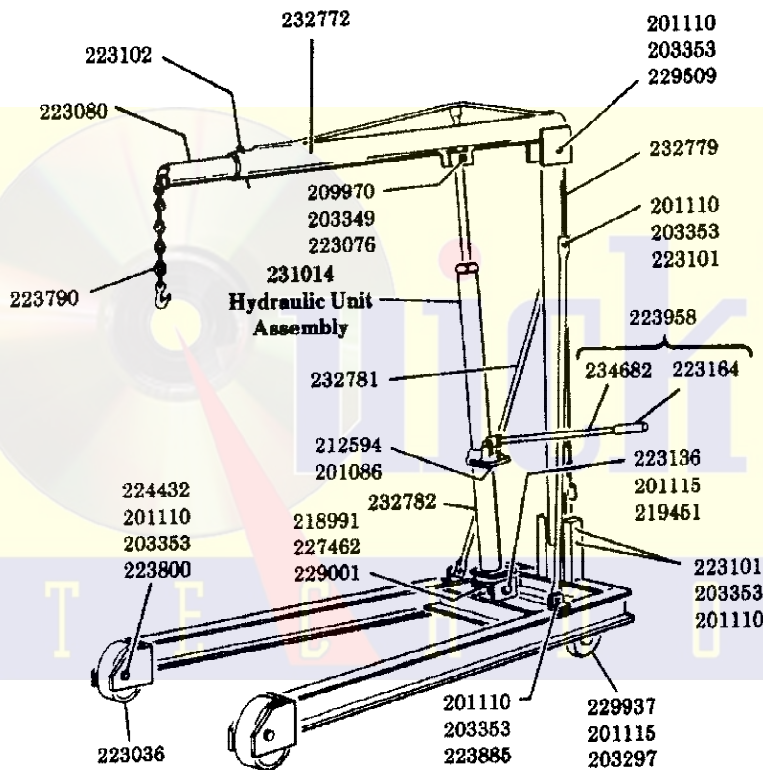

**231014
HYDRAULIC UNIT
ASSEMBLY**

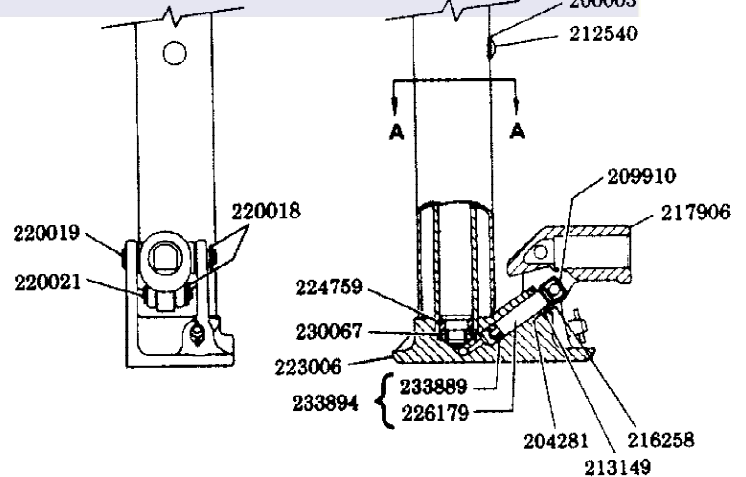
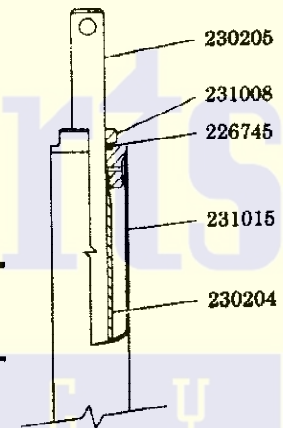

MODEL	LABEL KIT NO.	REPAIR KIT NO.
91-804	240052	91-397
93804	240053	240502
95804	240054	240502
YA-704	240055	240502

LINCOLN

A PENTAIR COMPANY

One Lincoln Way
St. Louis, Missouri 63120-1578
Customer Service: (314) 679-4300

SECTION - W5

PAGE - 5

TROUBLE SHOOTING

PROBLEM	SOLUTION
1) Will not lift load 2) Will not lift full height 3) Pump feels "Spongy" under load	The Jack could be low on oil- Refer to Instruction Manual. See instruction #5 under Maintenance Instructions. The Jack could be air-bound- Open the release valve one full turn and pump the handle about six full strokes to purge air from the pump and valving.
1) Will not lift load 2) Handle raises under load 3) Handle lowers under load 4) Will not hold load	Valve might not be closing- Make certain release valve is closed. Starting with boom in fully lowered position, SLOWLY raise the boom a few feet by hand. Open release valve and let the boom descend into lowered position. Crane should now operate properly.

If the above procedures do not correct the problem, contact your nearest service depot. When submitting any jack or equipment to be repaired, be sure to state the nature of the problem and indicate whether an estimate of the repair cost is needed.

IMPORTANT: As with any hydraulic unit, this unit may occasionally become "air-bound" due to being tipped over during shipment. To purge the air from the oil lines, open the release and pump rapidly a few strokes. Close release and pump to full height, then open the release to allow the ram to descend rapidly. If the pump still seems "spongy", repeat the procedure.

BOOM POSITION	CAPACITY (lbs.)	BOOM HEIGHT		BOOM LENGTH	REACH	CHAIN SIZE
		MAX.	MIN.			
#1	2,000	108"	32-1/2"	59-1/2"	40"	3/8"
#2	1,500	109"	31"	61-3/4"	43"	3/8"
#3	1,000	113"	27-1/2"	67-1/2"	49"	3/8"
#4	600	120"	20"	80"	62"	3/8"
#5	400	129"	9"	96"	77"	3/8"

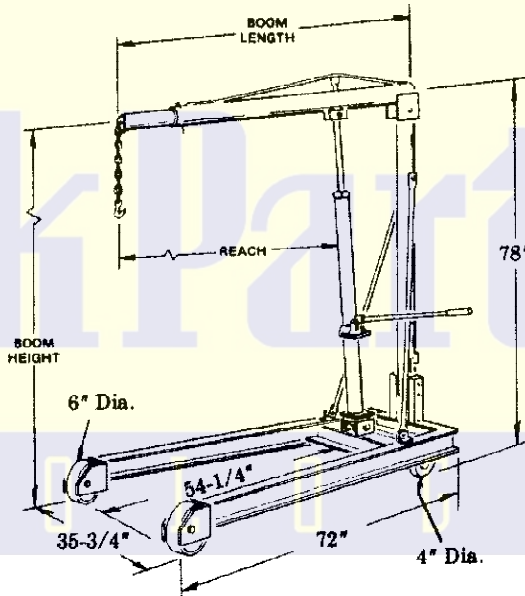

SERVICE PARTS

PART	QUAN.	DESCRIPTION	PART	QUAN.	DESCRIPTION	PART	QUAN.	DESCRIPTION
200003	1	Gasket	219451	1	Nut	227524	1	Release assembly
201086	4	Lockwasher	220018	2	Retaining ring	228830	1	Spring
201110	8	Lockwasher	220019	1	Pin	229001	1	Thrust bearing
201115	3	Lockwasher	220021	1	Pin	229509	1	Bolt
201138	1	Pin	221318	1	Screen	229937	2	Caster (rear)
203197	1	Ball, 3/16" Dia.	223006	1	Base	230067	1	U-cup
203201	1	Ball, 5/16" Dia.	223036	2	Wheel (front)	230204	1	Cylinder
203297	2	Nut	223076	1	Bolt	230205	1	Ram
203349	1	Nut	223080	1	Inner boom	231008	1	Tank nut
203363	8	Nut	223101	3	Bolt	231014	1	Hydraulic unit ass'y.
204281	1	Washer	223102	1	Position pin	231015	1	Oil tank
209910	1	Clip	223136	1	Bolt	232772	1	Main boom
209970	1	Lockwasher	223164	1	Grip	232779	1	Column
210311	1	Plug	223790	1	Lifting chain & hook	232781	2	Brace
212540	1	Filler screw	223800	2	Bolt	232782	1	Riser
212594	4	Bolt	223886	2	Bolt	233889	1	U-cup
213149	1	Packing ring	223958	1	Handle & grip ass'y.	233894	1	Pump assembly
216258	1	Cover	224432	2	Bushing	233917	1	Spring
217906	1	Handle socket	224759	1	Heel plate	233918	1	Release valve poppet
217909	1	Spring	226179	1	Piston	233923	1	Release stem
218776	2	O-ring	226745	1	Quad ring	234682	1	Handle
218991	1	Roll pin	227462	1	Yoke			